



KEMENTERIAN RISET DAN TEKNOLOGI/ BADAN RISET  
DAN INOVASI NASIONAL

**DEPUTI BIDANG PENGUATAN RISET DAN PENGEMBANGAN**

Jalan M.H. Thamrin Nomor 8, Jakarta 10340, Gedung II BPPT Lantai 19 – 20

Telepon: (021) 3169707; Faksimile: (021) 3101728, 3102368

Laman: [www.risbang.ristekdikti.go.id](http://www.risbang.ristekdikti.go.id)

Nomor : B/87/E3/RA.00/2020

28 Januari 2020

Lampiran : 4 (Empat) Berkas

Hal : **Pengumuman Penerima Pendanaan Penelitian dan Pengabdian kepada Masyarakat di Perguruan Tinggi Tahun Anggaran 2020**

Yth. 1. Rektor/ Direktur/ Ketua Perguruan Tinggi Negeri dan Swasta  
2. Kepala Lembaga Layanan Pendidikan Tinggi Wilayah I s/d XIV

Berdasarkan Keputusan Kuasa Pengguna Anggaran Deputy Bidang Penguatan Riset dan Pengembangan Kementerian Riset dan Teknologi/ Badan Riset dan Inovasi Nasional Nomor 7/E1/KPT/ 2020 tanggal 24 Januari 2020 tentang Penetapan Pendanaan Pengabdian kepada Masyarakat Tahun Anggaran 2020, Keputusan Kuasa Pengguna Anggaran Deputy Bidang Penguatan Riset dan Pengembangan Kementerian Riset dan Teknologi/ Badan Riset dan Inovasi Nasional Nomor 8/E1/KPT/ 2020 tanggal 24 Januari 2020 tentang Penetapan Pendanaan Penelitian di Perguruan Tinggi Tahun Anggaran 2020, dan Keputusan Kuasa Pengguna Anggaran Deputy Bidang Penguatan Riset dan Pengembangan Kementerian Riset dan Teknologi/ Badan Riset dan Inovasi Nasional Nomor 9/E1/KPT/ 2020 tanggal 24 Januari 2020 tentang Penetapan Hasil Review Pendanaan Penelitian Tahun Anggaran 2020, bersama ini kami sampaikan daftar nama penerima pendanaan Penelitian dan Pengabdian Kepada Masyarakat tahun anggaran 2020 sebagai berikut:

1. Penerima Pendanaan Penelitian di Perguruan Tinggi Non-PTNBH Usulan Tahun 2019 (Lampiran 1)
2. Penelitian Kontrak Tahun Jamak 2019-2021 yang dilanjutkan pendanaannya (Lampiran 2)
3. Penerima Pendanaan Pengabdian Kepada Masyarakat (Lampiran 3)

Kami informasikan bahwa penerima pendanaan Penelitian dan Pengabdian Kepada Masyarakat Tahun Anggaran 2020 adalah pengusul yang proposalnya dinyatakan lolos seleksi, dan yang bersangkutan atau institusi telah memenuhi kewajiban sebagai berikut:

1. Mengunggah laporan kemajuan sampai dengan tahun 2019;
2. Mengunggah laporan akhir sampai dengan tahun 2019;
3. Melaksanakan seluruh tahapan seleksi sebagaimana disebutkan dalam Panduan Pelaksanaan Penelitian dan Pengabdian Masyarakat Perguruan Tinggi Edisi XII Revisi Tahun 2019 untuk skema penelitian desentralisasi bagi Perguruan Tinggi klaster Mandiri, Utama, dan Madya sesuai dengan hasil klasterisasi tahun 2019;
4. Melaksanakan Monitoring dan Evaluasi penelitian secara daring sebagaimana surat Direktur DRPM dengan Nomor B/969/E3.1/RA.06/2019;
5. Mengunggah berkas kelengkapan seminar hasil bagi pelaksana Pengabdian kepada Masyarakat sampai dengan tahun 2019;
6. Tidak sedang dalam status tugas belajar baik untuk ketua maupun anggota, kecuali anggota pada skema Penelitian Pascasarjana;

7. Pendanaan penelitian diberikan dengan memperhatikan kuota berdasarkan h-index peneliti, kecuali untuk skema Penelitian Pascasarjana yang tidak dihitung sebagai kuota;
8. Hanya menjadi ketua di satu judul Pengabdian kepada Masyarakat, untuk pendanaan Pengabdian kepada Masyarakat tahun yang baru.

Adapun penelitian Penelitian Kontrak Tahun Jamak 2019-2021 yang dilanjutkan pendanaannya merupakan penelitian yang telah dinyatakan layak berdasarkan hasil monitoring dan evaluasi pada tahun 2019.

Apabila ada penerima pendanaan Penelitian dan Pengabdian Kepada Masyarakat sebagaimana tercantum pada lampiran ternyata tidak memenuhi salah satu dari ketentuan di atas, atau pelanggaran terhadap ketentuan Panduan Penelitian dan Pengabdian kepada Masyarakat Edisi XII Revisi Tahun 2019 maka pendanaannya dapat ditinjau kembali.

Berkenaan dengan hal tersebut, DRPM mengucapkan selamat kepada penerima pendanaan penelitian dan pengabdian kepada masyarakat tahun anggaran 2020. DRPM mengucapkan terimakasih kepada pengusul yang telah berpartisipasi, bagi pengusul yang belum mendapatkan pendanaan tahun ini dapat mengusulkan proposal penelitian dan pengabdian kepada masyarakat untuk pendanaan tahun 2021. Selanjutnya, kami mohon bantuan Bapak/Ibu untuk menyampaikan informasi di atas kepada nama-nama yang tercantum pada lampiran di Perguruan Tinggi masing-masing.

Perlu kami sampaikan bahwa mekanisme penyaluran dana akan dilakukan melalui kontrak. Berkaitan dengan hal ini, perlu kami sampaikan beberapa hal sebagai berikut:

1. Untuk penelitian, diterapkan kontrak tahun tunggal dan kontrak tahun jamak. Kontrak tahun tunggal digunakan untuk kontrak penelitian yang pendanaannya hanya 1 (satu) tahun, adapun kontrak tahun jamak digunakan untuk kontrak penelitian yang pendanaannya lebih dari 1 (satu) tahun.
2. Kontrak dilakukan secara berjenjang. Untuk Perguruan Tinggi Negeri (PTN), kontrak dilakukan antara DRPM dengan Ketua LP/LPPM/LPM/Direktur Politeknik, adapun untuk Perguruan Tinggi Swasta kontrak dilakukan melalui Kepala Lembaga Layanan Pendidikan Tinggi (LLDIKTI) masing - masing wilayah.
3. Pencairan dana penelitian dilakukan dengan 2 (dua) cara yaitu secara sekaligus dan secara bertahap;
4. Untuk Pengabdian kepada Masyarakat di tetapkan kontrak tahun tunggal bagi semua skema dan pencairannya dilaksanakan dalam 2 (dua) tahap.
5. Para penerima pendanaan Penelitian akan diminta untuk mengunggah perbaikan proposal dan RAB sesuai dengan dana yang diterima. Informasi lebih rinci terkait pengunggahan perbaikan proposal akan disampaikan kemudian.
6. Hal-hal lain yang terkait dengan penandatanganan kontrak, pencairan dana, dan pelaksanaan penelitian dan pengabdian kepada masyarakat akan diinformasikan lebih lanjut melalui laman: <http://simlibtamas.ristekdikti.go.id>.

Berkaitan dengan data yang diperlukan untuk penandatanganan kontrak, bersama ini kami kirimkan Daftar Isian (Lampiran 4). Kami mohon Daftar Isian tersebut dapat diisi dan segera dikirim melalui email ke alamat [tudrpm.ristekbrin@gmail.com](mailto:tudrpm.ristekbrin@gmail.com), untuk Penelitian CC ke alamat email [terapanriset@gmail.com](mailto:terapanriset@gmail.com) dengan subjek **Data Kontrak Penelitian** dan untuk Pengabdian Masyarakat CC ke alamat email [ppm.drpmristekbrin@gmail.com](mailto:ppm.drpmristekbrin@gmail.com) dengan subjek **Data Kontrak Pengabdian**, paling lambat tanggal 10 Februari 2020. Untuk PTS tidak perlu mengirimkan daftar isian karena Kontrak akan dilakukan dengan LLDIKTI Wilayah masing – masing.

Demikian kami sampaikan, atas perhatian dan kerjasama Bapak/Ibu kami ucapkan terima kasih.

Direktur Riset dan Pengabdian  
Masyarakat,

TTD

Ocky Karna Radjasa  
NIP 196510291990031001

Tembusan:  
Deputi Bidang Penguatan Riset dan Pengembangan;

## PENETAPAN HASIL REVIEW PENDANAAN PENELITIAN LANJUTAN DI PERGURUAN TINGGI TAHUN ANGGARAN 2020

NO	PTN / LLDIKTI	NAMA INSTITUSI	SKEMA	NAMA	NIDN	JUDUL	DURASI PENELITIAN (Tahun)	STATUS USULAN
1	PTN	Institut Pertanian Bogor	World Class Research	MIFTAHUDIN	0019046205	Aplikasi Teknologi Omik (Genomik, Transkriptomik, dan Metabolomik) untuk Identifikasi Gen yang Berguna dalam Pengembangan Varietas Padi Toleran Kekeringan dan Tanah Masam	2	lanjutan
2	PTN	Institut Pertanian Bogor	World Class Research	ANURAGA JAYANEGARA	0002068301	Evaluasi Efektivitas Pakan Suplemen dan Aditif Peningkat Produktivitas Ternak Ruminansia dan Anti-metanogenesis Menggunakan Pendekatan "Big Data Analytics"	3	lanjutan
3	PTN	Institut Pertanian Bogor	World Class Research	ARIEF BOEDIONO	0005036411	EKSPRESI MARKA GEN IMPLANTASI PADA EMBRIO PARTHENOGENESIS DAN FERTILISASI SPERMA TUNGGAL PADA KUCING SEBAGAI HEWAN MODEL FELIDAE	3	lanjutan
4	PTN	Institut Pertanian Bogor	World Class Research	BAMBANG SURYOBROTO	0026035802	Adaptation and speciation in Sulawesi macaques	3	lanjutan
5	PTN	Institut Pertanian Bogor	World Class Research	CECE SUMANTRI	0012125920	karakterisasi gen-gen pengontrol kualitas daging dan ketahanan penyakit pada ayam lokal dan IPB-D1 dengan analisis RNA Deep Sequencing	3	lanjutan
6	PTN	Institut Pertanian Bogor	World Class Research	RD RORO DYAH PERWITASARI	0003046613	Profil Genetik Sapi Madura	3	lanjutan
7	PTN	Institut Seni Budaya Indonesia Bandung	Penelitian Terapan	HUSEN HENDRIYANA	0010037204	Eco design : Eksplorasi dan Aplikasi Material Bahan Pandan Berduri untuk Mendukung Ekonomi Kreatif Kriya Seni dan Pariwisata di Pangandaran	3	lanjutan
8	PTN	Institut Seni Budaya Indonesia Bandung	Penelitian Terapan	YANTI HERIYAWATI	0006037705	Pengembangan Kearifan Lokal Budaya Maritim Nusantara melalui Festival Pesisir Utara dan Selatan Jawa Barat	3	lanjutan
9	PTN	Institut Seni Indonesia Denpasar	Penelitian Dasar	I NYOMAN LARRY JULIANTO	0014078302	Nilai Interaksi Terhadap Rangsang Visual Ilustrasi dan Warna Pada Ruang Belajar dalam Upaya Mendukung Pembelajaran Siswa SD Kelas 1 - 3 di Bali	3	lanjutan
10	PTN	Institut Seni Indonesia Denpasar	Penelitian Terapan	I WAYAN MUDRA	0025116306	WAYANG BALI SEBAGAI IDE PENCIPTAAN KERAMIK KARAKTER INDONESIA	3	lanjutan
11	PTN	Institut Seni Indonesia Denpasar	Penelitian Terapan	NI MADE RUASTITI	0022036503	APLIKASI MODEL SENI PERTUNJUKAN WAYANG WONG INOVATIF PADA GENERASI MILENIAL SEBAGAI UPAYA PELESTARIAN SENI BUDAYA DAN PENGUATAN KARAKTER BANGSA	3	lanjutan

NO	PTN / LLDIKTI	NAMA INSTITUSI	SKEMA	NAMA	NIDN	JUDUL	DURASI PENELITIAN (Tahun)	STATUS USULAN
1585	LLDIKTI WILAYAH VI	Universitas Katolik Soegijapranata	Penelitian Dasar Unggulan Perguruan Tinggi	BUDI WIDIANARKO	0623116201	Pengembangan Model Reduksi Timbulan Limbah Single Use Plastic Dari Produk Siap Santap di Convenience Store Berbasis Carbon Footprint dan Product Design	2	lanjutan
1586	LLDIKTI WILAYAH VI	Universitas Katolik Soegijapranata	Penelitian Dasar Unggulan Perguruan Tinggi	CECILIA TITIEK MURNIATI	0622096701	Pengaruh Sikap dan Self-efficacy Terhadap Penggunaan E-learning di Pendidikan Tinggi	2	lanjutan
1587	LLDIKTI WILAYAH VI	Universitas Katolik Soegijapranata	Penelitian Dasar Unggulan Perguruan Tinggi	SOEDARINI	0604026802	Mekanisme ionic bounding Na+ dan pengaruhnya terhadap sensitivitas deteksi aktivitas antioksidan metode DPPH.	2	lanjutan
1588	LLDIKTI WILAYAH VI	Universitas Katolik Soegijapranata	Penelitian Pasca Doktor	BUDI WIDIANARKO	0623116201	PENGEMBANGAN MODEL PRODUKSI BATIK RAMAH AIR: Evaluasi Jejak Air (Water Footprint) Batik Warna Alam dan Batik Warna Sintetis pada Industri Batik di Desa Jarum, Klaten	2	lanjutan
1589	LLDIKTI WILAYAH VI	Universitas Katolik Soegijapranata	Penelitian Terapan Unggulan Perguruan Tinggi	ALBERTA RIKA PRATIWI	0608056601	Pengembangan Produk Penyedap Rasa non MSG dari Ganggang (Seaweed) Asal Laut Indonesia	2	lanjutan
1590	LLDIKTI WILAYAH VI	Universitas Katolik Soegijapranata	Penelitian Terapan Unggulan Perguruan Tinggi	ANTONIUS SURATNO	0625026301	Kajian dan Pengembangan Model Belajar Blended Learning Menggunakan Augmented Reality untuk Belajar Mendengar dan Membaca bahasa Inggris	2	lanjutan
1591	LLDIKTI WILAYAH VI	Universitas Katolik Soegijapranata	Penelitian Terapan Unggulan Perguruan Tinggi	BERNADINUS HARNADI	0621056901	Model dan implementasi Industri Kreatif Digital Berbasis Adopsi Teknologi Informasi Generasi Y dan Z	2	lanjutan
1592	LLDIKTI WILAYAH VI	Universitas Katolik Soegijapranata	Penelitian Terapan Unggulan Perguruan Tinggi	BUDI WIDIANARKO	0623116201	PENGEMBANGAN METODE STANDAR UNTUK DETEKSI DAN KUANTIFIKASI MIKROPLASTIK DALAM BAHAN PANGAN HASIL LAUT (SEAFOOD) BERBASIS FOURIER TRANSFORM INFRA RED (FTIR)-IMAGING MICROSCOPY	2	lanjutan
1593	LLDIKTI WILAYAH VI	Universitas Katolik Soegijapranata	Penelitian Terapan Unggulan Perguruan Tinggi	FLORENTINUS BUDI SETIAWAN	0616107001	Perancangan Alat Deteksi Pergerakan Tanah di Daerah Rawah Longsor	2	lanjutan
1594	LLDIKTI WILAYAH VI	Universitas Katolik Soegijapranata	Penelitian Terapan Unggulan Perguruan Tinggi	MARIA G WESTRI K SUSILOWATI	0624046901	Pengembangan Strategi Memajukan UMKM Bidang Pariwisata Berbasis Masyarakat dan Potensi Wilayah Kawasan Wisata Kabalong Pekalongan	2	lanjutan
1595	LLDIKTI WILAYAH VI	Universitas Katolik Soegijapranata	Penelitian Terapan Unggulan Perguruan Tinggi	R PROBO YULIANTO NUGRAHEDI	0625077501	Aplikasi Gelombang Ultrasonik dalam Ekstraksi Senyawa Bioaktif di Rumput Laut	2	lanjutan
1596	LLDIKTI WILAYAH VI	Universitas Katolik Soegijapranata	Penelitian Terapan Unggulan Perguruan Tinggi	V KRISTINA ANANINGSIH	0623127302	Optimasi Proses Ekstraksi Ultrasonik dan Mikroenkapsulasi Oleoresin Biji Pala	2	lanjutan

**LAPORAN TAHUN I  
HIBAH PENELITIAN KOMPETITIF  
(PENELITIAN TERAPAN)**

**LEMBAGA PENELITIAN DAN PENGABDIAN KEPADA MASYARAKAT  
SOEGIJAPRANATA CATHOLIC UNIVERSITY**

Jl. Pawiyatan Luhur IV/1 Bendan Duwur Semarang 50234  
Telp. (024) 8441555, 8505003 (hunting) Fax. (024) 8415429 - 8445265  
e-mail: unika@unika.ac.id http://www.unika.ac.id



**LEMBAR PENGESAHAN  
PROPOSAL/LAPORAN KEMAJUAN/LAPORAN AKHIR  
PROGRAM PENELITIAN**

1. Judul Penelitian : Model dan implementasi Industri Kreatif Digital Berbasis Adopsi Teknologi Informasi Generasi Y dan Z
2. Bidang Fokus : Teknologi Informasi
3. Skema : Penelitian Dasar Unggulan Perguruan Tinggi
4. Ketua Tim :
  - a. Nama : Dr. Bernardinus Harnadi, ST.,MT
  - b. Jabatan/Golongan : Lektor Kepala/IV B
  - c. NIDN : 0621056901
  - d. Program Studi : Fakultas Ilmu Komputer
5. Nama Anggota Tim :
  - a. Albertus Dwi Yoga Widiyanto, S.Kom., M.Kom (0605017301)
  - b. FX. Hendra Prasetya, ST.,MT. ( 0615107101)
6. Luaran Yang dihasilkan : Jurnal, proceeding, dan HKI
7. Sumber Dana : DIKTI
8. Total dana : Rp 138.865.000,00
9. Waktu Pelaksanaan : 27 Februari - 20 Desember 2019



Dr. Berta Berti Retnawati, SE, M.Si  
NIDN: 0606097302

Semarang,

Ketua Tim Peneliti

Dr. Bernardinus Harnadi, ST.,MT  
NIDN.0630107101



## SURAT KETERANGAN

Nomor : 0063/H.3/ST.REK/IX/2024

Yang bertandatangan di bawah ini:

N a m a : Dr. Ferdinandus Hindiarto, S.Psi., M.Si.

Jabatan : Rektor Universitas Katolik Soegijapranata

Dengan ini menyampaikan bahwa berdasarkan ketentuan Pasal 202 Peraturan Universitas Katolik Soegijapranata Nomor 01/E.2/PER-UKS/XI/2019 tentang Organisasi dan Tata Kelola, bahwa untuk kepentingan administrasi dalam penugasan Dosen dan Tenaga Kependidikan yang bersifat temporer dilakukan dalam bentuk penerbitan Surat Tugas.

Demikian Surat Keterangan ini diterbitkan untuk dapat digunakan sebagaimana mestinya.

Semarang, 19 September 2024

Rektor



Dr. Ferdinandus Hindiarto, S.Psi., M.Si.



**LEMBAGA PENELITIAN DAN PENGABDIAN KEPADA MASYARAKAT**

Jl. Pawiyatan Luhur IV/1 Bendan Duwur Semarang 50234  
Telp. (024) 8441555, 8505003 (ext. 1461, 1462), Fax. (024) 8445265  
e-mail: lppm@unika.ac.id, lppm.unikasmg@gmail.com  
http://www.unika.ac.id



# **SURAT TUGAS**

**Nomor : 00420/B.7.2/ST-LPPM/II/2019**

**Kepala Lembaga Penelitian dan Pengabdian Kepada Masyarakat Universitas Katolik Soegijapranata Semarang dengan ini memberi tugas kepada :**

- Nama** : **Dr. Bernardinus Harnadi, ST.,MT (Ketua)**  
**Albertus Dwi Yoga Widiatoro, S.Kom, M.Kom (Anggota)**  
**FX. Hendra Prasetya, S.T., M.T (Anggota)**
- Status** : **Dosen Tetap Universitas Katolik Soegijapranata Semarang**
- Tugas** : **Penelitian Ristek Dikti tahun anggaran 2019 Skim Penelitian Terapan Unggulan Perguruan Tinggi dengan judul "Model dan implementasi Industri Kreatif Digital Berbasis Adopsi Teknologi Informasi Generasi Y dan Z"**
- Penyelenggara** : **Ristek Dikti**
- Waktu** : **27 Februari – 20 Desember 2019**
- Lain-lain** : **Harap melaksanakan tugas dengan sebaik-baiknya dan penuh tanggung jawab serta memberikan laporan setelah selesai melaksanakan tugas.**

**Demikian surat tugas ini dibuat untuk dapat dipergunakan sebagaimana mestinya.**

Semarang, 27 Februari 2019

Kepala LPPM



**Dr. Berta Berti Retnawati, MSi**

**NPP.058.1.1998.219**

**LEMBAGA PENELITIAN DAN PENGABDIAN KEPADA MASYARAKAT**

Jl. Pawiyatan Luhur IV/1 Beridan Duwur Semarang 50234  
Telp. (024) 8441555, 8505003 (ext. 1461, 1462), Fax. (024) 8445265  
e-mail: lppm@unika.ac.id, lppm.unikasmg@gmail.com  
http://www.unika.ac.id



**SURAT PENUGASAN PENELITIAN  
PELAKSANAAN PROGRAM MULTI TAHUN  
DANA RISTEK DIKTI  
TAHUN ANGGARAN 2019**

**(Nomor SK: 010/L6/AK/SP2H.1/PENELITIAN/2019)  
Nomor surat : 00621/B.7.2/LPPM/05/2019**

Pada hari ini Kamis tanggal 2 (dua) bulan Mei tahun **Dua Ribu Sembilan Belas**, kami yang bertandatangan di bawah ini :

1. **Dr. Berta Bekti Retnawati, MSi** sebagai Kepala LPPM Universitas Katolik Soegijapranata Semarang, selanjutnya disebut sebagai **PIHAK PERTAMA**
2. **Dr. Bernardinus Harnadi, ST.,MT**, sebagai Ketua Peneliti, **Skim: Penelitian Terapan Unggulan Perguruan Tinggi**, dengan judul "Model dan implementasi Industri Kreatif Digital Berbasis Adopsi Teknologi Informasi Generasi Y dan Z", selanjutnya disebut **PIHAK KEDUA**

Berdasarkan Surat Perjanjian Lembaga Layanan Pendidikan Tinggi (LLDikti) Wilayah VI Nomor: 010/L6/AK/SP2H.1/PENELITIAN/2019, maka **PIHAK KEDUA** akan menjalankan kewajiban pelaksanaan penelitian tersebut di atas sesuai ketentuan yang ditetapkan berdasarkan Surat Perjanjian LLDikti Wilayah VI tersebut, serta bersedia bertanggung jawab dan/atau dikenai sanksi apabila ada hal-hal yang tidak dilaksanakan sesuai ketentuan dalam surat Perjanjian LLDikti Wilayah VI tersebut di atas.

**PIHAK KEDUA** akan mendapat dana penelitian tahun pertama sebesar **Rp. 138.865.000,-** (Seratus tiga puluh delapan juta delapan ratus enam puluh lima ribu rupiah) sesuai dengan ketentuan Direktorat Jendral Pendidikan Tinggi, dengan ketentuan sebagai berikut :

1. Periode Penelitian **PIHAK KEDUA** untuk **2 (dua) tahun** yaitu **2019-2020**. Untuk keberlanjutan penelitian ditentukan berdasarkan hasil penilaian atas capaian tahun berjalan yang dilakukan oleh Komite Penilaian Keluaran Penelitian dan/atau Reviewer Keluaran Penelitian sesuai ketentuan dari pemberi dana.
2. Tim Peneliti akan menerima pencairan dana dalam satu tahap yakni 100% (diterimakan setelah ada pencairan dana dari LLDIKTI)
3. **PIHAK KEDUA** harus mengunggah ke laman simlitabmas :
  - a. **Laporan Kemajuan (disertai Laporan Keuangan 70%) & Catatan Harian** paling lambat **Sabtu, 7 September 2019**.
  - b. **Mengunggah SPTB 100% (Surat Pernyataan Tanggungjawab Belanja)** yang sudah diberi meterai 6 ribu dan di tandatangani Ketua Peneliti paling lambat **Sabtu, 7 September 2019**.
  - c. Menyerahkan FC SPTB tersebut ke LPPM paling lambat **Selasa, 10 September 2019**
4. **Ketua Peneliti WAJIB** mengunggah :
  - a. **Laporan Akhir & Luaran Penelitian** paling lambat **Sabtu, 9 November 2019**

**LEMBAGA PENELITIAN DAN PENGABDIAN KEPADA MASYARAKAT**

Jl. Pawiyatan Luhur IV/1 Benda Duwur Semarang 50234  
Telp. (024) 8441555, 8505003 (ext. 1461, 1462), Fax. (024) 8445265  
e-mail: [lppm@unika.ac.id](mailto:lppm@unika.ac.id), [lppm.unikasmg@gmail.com](mailto:lppm.unikasmg@gmail.com)  
<http://www.unika.ac.id>



- b. Laporan Akhir Keuangan 100% & Mengisi Catatan Harian 100% paling lambat Sabtu, 9 November 2019
- c. Laporan hasil Penelitian ditulis dalam format font Times New Romans ukuran 12, spasi 1,5; kertas A4 pada sampul (cover) ditulis :

**Dibiayai oleh:**

**Direktorat Riset dan Pengabdian Masyarakat  
Direktorat Jendral Penguatan Riset dan Pengembangan  
Kementerian Riset, Teknologi, dan Pendidikan Tinggi  
Sesuai dengan Kontrak Penelitian Tahun Anggaran 2019  
Nomor : 010/L6/AK/SP2H.1/PENELITIAN/2019**

- 5. Ketua Peneliti wajib menyerahkan :
  - a. FC laporan akhir hasil penelitian beserta luaran wajib dan tambahan (bila ada), dijilid jadi satu dengan warna cover bebas sebanyak 2 exp (untuk LLDIKTI dan LPPM)
  - b. Fotocopy laporan keuangan 100% beserta nota-notanya dalam bentuk fisik (di bedakan 70 % dan 30 %) sebanyak 2 exp
  - c. FC bukti bayar pajak PPN sebesar 10% dan PPh 22 sebesar 1,5% serta pajak-pajak lain sesuai ketentuan yang berlaku dilampirkan dalam Laporan Keuangan
  - d. Softcopy laporan akhir dan luaran serta laporan keuangan excel 100 %, dikirim ke email [lppm@unika.ac.id](mailto:lppm@unika.ac.id) ; cc: [tu.lppm@unika.ac.id](mailto:tu.lppm@unika.ac.id) dengan nama file : NAMA KETUA\_SKIM\_LAPORAN\_AKHIR\_2019 paling lambat 9 November 2019

Terkait dengan pelaksanaan penelitian berdasarkan Surat Perjanjian tersebut diatas, **PIHAK PERTAMA** dapat menetapkan peraturan/kebijakan kelembagaan yang diperlukan terhadap **PIHAK KEDUA** :

- 1. Setiap Publikasi, makalah dan/atau ekspos dalam bentuk apapun yang berkaitan dengan hasil penelitian ini **WAJIB** mencantumkan pemberi dana penelitian yaitu : **DIREKTORAT RISET DAN PENGABDIAN MASYARAKAT, DIREKTORAT JENDRAL PENGUATAN RISET DAN PENGEMBANGAN, KEMENTERIAN RISET, TEKNOLOGI, DAN PENDIDIKAN TINGGI** sebagai pemberi dana.
- 2. Hasil Penelitian berupa peralatan dan/atau peralatan yang dibeli dari kegiatan ini adalah milik Negara, dan dapat dihibahkan kepada institusi/lembaga melalui Berita Acara Serah Terima (BAST).
- 3. Pengajuan Hak Kekayaan Intelektual (Hak Cipta maupun Paten) hasil dari riset hibah ini memakai pemegang hak cipta lembaga, dalam hal ini adalah LPPM Unika Soegijapranata
- 4. Pihak KEDUA wajib menyelesaikan seluruh pekerjaan dan wajib menghasilkan luaran yang dijanjikan baik luaran wajib maupun luaran tambahan. Bila tidak memenuhi

**LEMBAGA PENELITIAN DAN PENGABDIAN KEPADA MASYARAKAT**

Jl. Pawiyatan Luhur IV/1 Bendan Duwur Semarang 50234  
Telp. (024) 8441555, 8505003 (ext. 1461, 1462), Fax. (024) 8445265  
e-mail: lppm@unika.ac.id, lppm.unikasmg@gmail.com  
http://www.unika.ac.id



kewajiban ini PIHAK KEDUA bersedia menerima sanksi administratif yang ditentukan oleh pihak pemberi dana.

5. Bila sampai batas waktu yang telah ditetapkan oleh DRPM untuk melaksanakan penugasan penelitian telah berakhir, PIHAK KEDUA tidak melaksanakan kewajiban sebagaimana yang sudah diatur dalam Surat Penugasan ini, maka PIHAK KEDUA dikenai sanksi administratif. Sesuai dengan ketentuan pihak pemberi dana, sanksi administratif dapat berupa penghentian, pembayaran, dan tidak dapat mengajukan proposal penelitian dalam kurun waktu dua tahun berturut-turut.
6. Peneliti wajib menggunakan keseluruhan dana sesuai pagu dana yang diberikan oleh DRPM (tidak boleh bersisa).
7. Hal-hal yang belum diatur dalam Kontrak Penelitian ini akan diatur kemudian oleh kedua belah pihak.

PIHAK PERTAMA



Dr. Berta Bekti Retnawati, MSi  
NPP. 058.1.1998.219

PIHAK KEDUA

Dr. Bernardinus Harnadi, ST.,MT  
NPP. 058.1.1994.158



### PROTEKSI ISI LAPORAN KEMAJUAN PENELITIAN

Dilarang menyalin, menyimpan, memperbanyak sebagian atau seluruh isi laporan ini dalam bentuk apapun kecuali oleh peneliti dan pengelola administrasi penelitian

## LAPORAN KEMAJUAN PENELITIAN MULTI TAHUN

ID Proposal: f386d514-1586-47b4-8e1a-97946ee393b4  
Laporan Kemajuan Penelitian: tahun ke-1 dari 2 tahun

### 1. IDENTITAS PENELITIAN

#### A. JUDUL PENELITIAN

Model dan implementasi Industri Kreatif Digital Berbasis Adopsi Teknologi Informasi Generasi Y dan Z

#### B. BIDANG, TEMA, TOPIK, DAN RUMPUN BIDANG ILMU

Bidang Fokus RIRN / Bidang Unggulan Perguruan Tinggi	Tema	Topik (jika ada)	Rumpun Bidang Ilmu
Pengembangan Industri Kreatif dan UMKM	-	Pengembangan Potensi Sumber Daya Lokal Berbasis Industri Kreatif	Sistem Informasi

#### C. KATEGORI, SKEMA, SBK, TARGET TKT DAN LAMA PENELITIAN

Kategori (Kompetitif Nasional/ Desentralisasi/ Penugasan)	Skema Penelitian	Strata (Dasar/ Terapan/ Pengembangan)	SBK (Dasar, Terapan, Pengembangan)	Target Akhir TKT	Lama Penelitian (Tahun)
Penelitian Desentralisasi	Penelitian Terapan Unggulan Perguruan Tinggi	SBK Riset Terapan	SBK Riset Terapan	6	2

### 2. IDENTITAS PENGUSUL

Nama, Peran	Perguruan Tinggi/ Institusi	Program Studi/ Bagian	Bidang Tugas	ID Sinta	H-Index
BERNADINUS HARNADI Ketua Pengusul	Universitas Katolik Soegijapranata	Sistem Informasi		5976331	1
ALBERTUS DWI YOGA WIDIANTORO S.Kom, M.Kom Anggota Pengusul 1	Universitas Katolik Soegijapranata	Sistem Informasi		9803	1
FX HENDRA PRASETYA S.T, M.T	Universitas Katolik Soegijapranata	Sistem Informasi		6131369	0

Anggota Pengusul 2					
-----------------------	--	--	--	--	--

### 3. MITRA KERJASAMA PENELITIAN (JIKA ADA)

Pelaksanaan penelitian dapat melibatkan mitra kerjasama, yaitu mitra kerjasama dalam melaksanakan penelitian, mitra sebagai calon pengguna hasil penelitian, atau mitra investor

Mitra	Nama Mitra
Mitra Calon Pengguna	Andre Setiawan

### 4. LUARAN DAN TARGET CAPAIAN

#### Luaran Wajib

Tahun Luaran	Jenis Luaran	Status target capaian ( <i>accepted, published, terdaftar atau granted, atau status lainnya</i> )	Keterangan ( <i>url dan nama jurnal, penerbit, url paten, keterangan sejenis lainnya</i> )
1	Model	produk	

#### Luaran Tambahan

Tahun Luaran	Jenis Luaran	Status target capaian ( <i>accepted, published, terdaftar atau granted, atau status lainnya</i> )	Keterangan ( <i>url dan nama jurnal, penerbit, url paten, keterangan sejenis lainnya</i> )
1	Prosiding dalam pertemuan ilmiah Internasional	sudah terbit/sudah dilaksanakan	
1	Hak Cipta	granted	
1	Prosiding dalam pertemuan ilmiah Nasional	sudah terbit/sudah dilaksanakan	Seminar Nasional Aplikasi Teknologi Informasi (SNATI)

### 5. ANGGARAN

Rencana anggaran biaya penelitian mengacu pada PMK yang berlaku dengan besaran minimum dan maksimum sebagaimana diatur pada buku Panduan Penelitian dan Pengabdian kepada Masyarakat Edisi 12.

**Total RAB 2 Tahun Rp. 283,040,000**

**Tahun 1 Total Rp. 138,865,000**

Jenis Pembelanjaan	Item	Satuan	Vol.	Biaya Satuan	Total
Analisis Data	HR Pengolah Data	P (penelitian)	1	1,540,000	1,540,000
Bahan	ATK	Paket	1	3,400,000	3,400,000
Pelaporan, Luaran Wajib, dan Luaran Tambahan	Biaya seminar nasional	Paket	1	6,951,000	6,951,000
Pelaporan, Luaran Wajib, dan Luaran Tambahan	Biaya seminar internasional	Paket	1	17,450,000	17,450,000
Pelaporan, Luaran Wajib, dan Luaran Tambahan	Luaran KI (paten, hak cipta dll)	Paket	1	1,000,000	1,000,000
Pengumpulan Data	FGD persiapan penelitian	Paket	2	5,500,000	11,000,000

Jenis Pembelanjaan	Item	Satuan	Vol.	Biaya Satuan	Total
Pengumpulan Data	Transport	OK (kali)	18	1,000,000	18,000,000
Pengumpulan Data	Tiket	OK (kali)	18	2,000,000	36,000,000
Pengumpulan Data	Penginapan	OH	18	648,000	11,664,000
Pengumpulan Data	Uang Harian	OH	27	180,000	4,860,000
Pengumpulan Data	HR Pembantu Peneliti	OJ	360	25,000	9,000,000
Pengumpulan Data	HR Petugas Survei	OH/OR	1000	8,000	8,000,000
Pengumpulan Data	Biaya konsumsi	OH	1000	10,000	10,000,000

#### Tahun 2 Total Rp. 144,175,000

Jenis Pembelanjaan	Item	Satuan	Vol.	Biaya Satuan	Total
Analisis Data	Biaya analisis sampel	Unit	2	4,150,000	8,300,000
Analisis Data	Transport Lokal	OK (kali)	2	2,650,000	5,300,000
Analisis Data	Biaya konsumsi rapat	OH	2	4,612,500	9,225,000
Bahan	ATK	Paket	1	3,400,000	3,400,000
Bahan	Bahan Penelitian (Habis Pakai)	Unit	2	10,100,000	20,200,000
Pelaporan, Luaran Wajib, dan Luaran Tambahan	Biaya seminar nasional	Paket	1	5,500,000	5,500,000
Pelaporan, Luaran Wajib, dan Luaran Tambahan	Biaya seminar internasional	Paket	1	22,000,000	22,000,000
Pelaporan, Luaran Wajib, dan Luaran Tambahan	Publikasi artikel di Jurnal Internasional	Paket	1	50,000,000	50,000,000
Pengumpulan Data	HR Pembantu Peneliti	OJ	360	25,000	9,000,000
Sewa Peralatan	Peralatan penelitian	Unit	1	11,250,000	11,250,000

## 6. KEMAJUAN PENELITIAN

**A. RINGKASAN:** Tuliskan secara ringkas latar belakang penelitian, tujuan dan tahapan metode penelitian, luaran yang ditargetkan, serta uraian TKT penelitian.

Sektor ekonomi kreatif termasuk industri kreatif digital terbukti mampu memberikan sumbangan yang signifikan pada peningkatan pendapatan nasional, penyediaan lapangan kerja, dan kenaikan nilai ekspor Indonesia. Dengan besarnya pengguna internet dan ponsel pintar serta pesatnya pertumbuhan transaksi e-commerce di kalangan generasi Y dan Z maka Indonesia menjadi pasar potensial bagi industri kreatif digital. Investigasi mendalam ke dalam kedua generasi ini dalam bentuk pengembangan model adopsi teknologi informasi akan memberikan kontribusi yang berharga dalam pengembangan model dan implementasi industri kreatif digital di Indonesia.

Penelitian tahun pertama ini memiliki tujuan mengembangkan model adopsi teknologi informasi diantara generasi Y dan Z yang akan digunakan untuk pengembangan dan implementasi industri kreatif digital di Indonesia di tahun kedua.

Untuk mencapai tujuan penelitian yang ditargetkan peneliti menerapkan metode dengan dua tahun pentahapan. Tahun pertama dimulai dengan melakukan pengkajian terhadap teori yang relevan untuk mendapatkan faktor yang tepat dan dapat digunakan untuk membangun model dan instrumen penelitian. Setelah memiliki instrumen penelitian dan membangun kuesioner, survey dilakukan pada pengguna teknologi informasi generasi X dan Y yang terbagi pada topik teknologi bisnis, teknologi hiburan, teknologi keuangan, dan teknologi sosial media. Hasil survey dianalisis dengan metode statistik dan hasilnya di diskusikan dalam skema FGD dengan perwakilan kedua generasi. Hasil analisis statistik dan FGD berupa model adopsi menjadi masukan dalam pengembangan dan implementasi potensi industri kreatif digital. Seluruh kegiatan ini akan menjadi model bagi pengembangan industri kreatif digital berbasis adopsi teknologi informasi. Penelitian ini menghasilkan model adopsi teknologi e-commerce, teknologi media online entertain, dan teknologi pembelajaran melalui smartphone. Model yang dihasilkan didaftarkan hak ciptanya dan hasil penelitian dipublikasikan dalam konferensi internasional serta menjadi target luaran tahun pertama. Dari segi tingkat kesiapan teknologi penelitian tahun pertama berada pada TKT 5.

Penelitian ini memberikan kontribusi bagi pengembangan dan implementasi industri kreatif di Indonesia melalui penggunaan model yang dihasilkan. Demikian juga bagi mereka yang berkepentingan terhadap hasil penelitian behavioral pada generasi Y dan Z terutama para pelaku pasar yang menjadikan kedua generasi tersebut sebagai pasar potensial dan para pengambil keputusan di dalam pengembangan dan implementasi industri kreatif digital di Indonesia.

**B. KATA KUNCI:** Tuliskan maksimal 5 kata kunci.

industri kreatif digital; model; implementasi; generasi Y; generasi Z

Pengisian poin C sampai dengan poin H mengikuti template berikut dan tidak dibatasi jumlah kata atau halaman namun disarankan seringkas mungkin. Dilarang menghapus/memodifikasi template ataupun menghapus penjelasan di setiap poin.

**C. HASIL PELAKSANAAN PENELITIAN:** Tuliskan secara ringkas hasil pelaksanaan penelitian yang telah dicapai sesuai tahun pelaksanaan penelitian. Penyajian dapat berupa data, hasil analisis, dan capaian luaran (wajib dan atau tambahan). Seluruh hasil atau capaian yang dilaporkan harus berkaitan dengan tahapan pelaksanaan penelitian sebagaimana direncanakan pada proposal. Penyajian data dapat berupa gambar, tabel, grafik, dan sejenisnya, serta analisis didukung dengan sumber pustaka primer yang relevan dan terkini.



Pengisian poin C sampai dengan poin H mengikuti template berikut dan tidak dibatasi jumlah kata atau halaman namun disarankan ringkas mungkin. Dilarang menghapus/memodifikasi template ataupun menghapus penjelasan di setiap poin.

**C. HASIL PELAKSANAAN PENELITIAN:** Tuliskan secara ringkas hasil pelaksanaan penelitian yang telah dicapai sesuai tahun pelaksanaan penelitian. Penyajian meliputi data, hasil analisis, dan capaian luaran (wajib dan atau tambahan). Seluruh hasil atau capaian yang dilaporkan harus berkaitan dengan tahapan pelaksanaan penelitian sebagaimana direncanakan pada proposal. Penyajian data dapat berupa gambar, tabel, grafik, dan sejenisnya, serta analisis didukung dengan sumber pustaka primer yang relevan dan terkini.

Tahun pertama penelitian bertujuan menghasilkan model adopsi teknologi informasi seperti yang tercantum dalam Tabel 1

Tabel 1 Hasil dan luaran yang dicapai penelitian tahun ke-1(satu)

No	Hasil Penelitian	Luaran yang dicapai
1.	Model adopsi teknologi E-Commerce untuk generasi Z dan Y	Dengan luaran HKI Artikel konferensi Internasional terindeks scopus
2.	Model adopsi teknologi smartphone untuk pembelajaran	Artikel konferensi Internasional terindeks scopus
3.	Model adopsi teknologi media online entertain untuk generasi Z dan Y	Draf artikel journal internasional

Hasil Penelitian

Luaran wajib penelitian berupa model adopsi teknologi informasi pada generasi Z dan Y yang terbagi pada teknologi E-Commerce (bisnis dan keuangan) dan teknologi media online entertain serta model adopsi smartphone untuk pembelajaran. Model dihasilkan dengan menganalisis dan mengevaluasi model adopsi tersebut pada generasi Z dan Y. Model adopsi teknologi informasi yang dihasilkan ini akan digunakan untuk masukan bagi implementasi industri kreatif digital berbasis adopsi teknologi informasi generasi Z dan Y.

Model adopsi teknologi E-Commerce untuk generasi Z dan Y

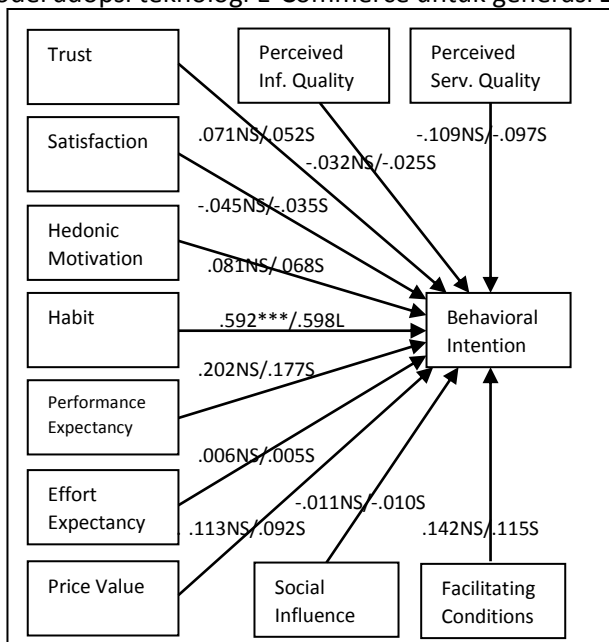

Gambar 1 Model adopsi teknologi E-commerce untuk generasi Z dan Y

H1: Perceived Information Quality (IQ) diprediksi memiliki pengaruh langsung yang signifikan secara statistik terhadap Behavioral Intention untuk menggunakan teknologi e-commerce.

H2: Perceived Service Quality (SQ) diprediksi memiliki pengaruh langsung yang signifikan secara statistik terhadap Behavioral Intention untuk menggunakan teknologi e-commerce.

H3: Trust (TR) diprediksi memiliki pengaruh langsung yang signifikan secara statistik terhadap Behavioral Intention untuk menggunakan teknologi e-commerce.

H4: Satisfaction (SF) diprediksi memiliki pengaruh langsung yang signifikan secara statistik terhadap Behavioral Intention untuk menggunakan teknologi e-commerce..

H5: Hedonic Motivation (HM) diprediksi memiliki pengaruh langsung yang signifikan secara statistik terhadap Behavioral Intention untuk menggunakan teknologi e-commerce.

H6: Performance Expectancy (PE) diprediksi memiliki pengaruh langsung yang signifikan secara statistik terhadap Behavioral Intention untuk menggunakan teknologi e-commerce.

H7: Effort Expectancy (EE) diprediksi memiliki pengaruh langsung yang signifikan secara statistik terhadap Behavioral Intention untuk menggunakan teknologi e-commerce.

H8: Price Value (PV) diprediksi memiliki pengaruh langsung yang signifikan secara statistik terhadap Behavioral Intention untuk menggunakan teknologi e-commerce.

H9: Facilitating Conditions (FC) diprediksi memiliki pengaruh langsung yang signifikan secara statistik terhadap Behavioral Intention untuk menggunakan teknologi e-commerce..

H10: Social Influence (SI) diprediksi memiliki pengaruh langsung yang signifikan secara statistik terhadap Behavioral Intention untuk menggunakan teknologi e-commerce..

H11: Habit (HB) diprediksi memiliki pengaruh langsung yang signifikan secara statistik terhadap Behavioral Intention untuk menggunakan teknologi e-commerce.

Hasil Analisa Hipotesa:

Hasil analisa hipotesa menyatakan bahwa H1, H2, H3, H4, H5, H6, H7, H8, H9, dan H10 adalah “partially support“ dan H11 “fully support.”

#### Perbedaan Adopsi Teknologi E-Commerce Technology antara generasi Z and Y

Tabel 2. Hasil analisis perbedaan adopsi antara generasi Z dan Y

Effect	Z generation (N = 248)				Y generation (N =95)			
	Unstandardized Estimate	Statistical Significance	Standardized Estimate	Magnitude	Unstandardized Estimate	Statistical Significance	Standardized Estimate	Magnitude
IQ→ BI	-.084	NS	-.071	S	-.023	NS	-.017	S
SQ→ BI	-.112	NS	-.107	M	-.082	NS	-.060	S
TR→ BI	.042	NS	.034	S	.162	NS	.092	S
SF→ BI	-.021	NS	-.016	S	-.043	NS	-.033	S
HM → BI	-.042	NS	-.040	S	.449	NS	.264	M
HB→	.611	***	.647	L	.703	***	.627	L

BI								
PE→ BI	.254	NS	.217	M	.106	NS	.097	S
EE→ BI	.005	NS	.004	S	-.074	NS	-.063	S
PV→ BI	.216	NS	.189	M	-.147	NS	-.103	M
SI→ BI	-.046	NS	-.045	S	.045	NS	.034	S
FC→ BI	.164	NS	.136	M	.164	NS	.126	M

Note: \*\*\* indicate statistical significance at a level of 0.001 and NS indicates not statistically significant at a level of 0.05 or less.

Model adopsi teknologi smartphone untuk pembelajaran

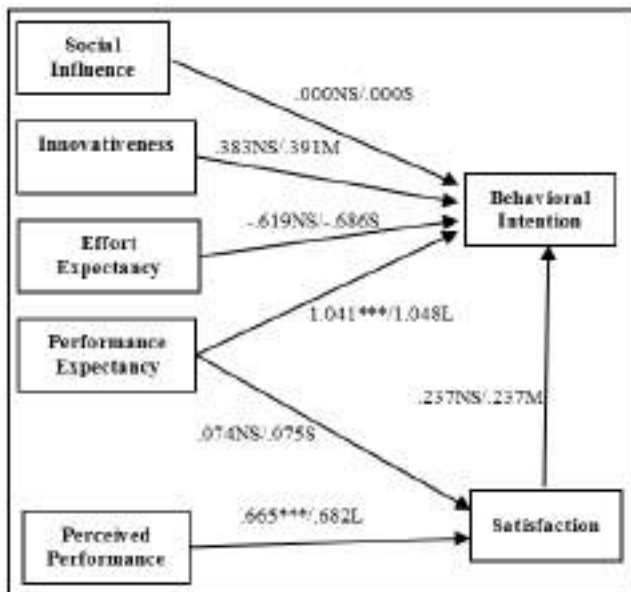

Gambar 2 Model adopsi teknologi smartphone untuk pembelajaran

H1: Social Influence diprediksi memiliki pengaruh langsung yang signifikan secara statistik terhadap Behavioral Intention dalam penggunaan teknologi smartphone untuk pembelajaran

H2: Innovativeness diprediksi memiliki pengaruh langsung yang signifikan secara statistik terhadap Behavioral Intention dalam penggunaan teknologi smartphone untuk pembelajaran

H3: Effort Expectancy diprediksi memiliki pengaruh langsung yang signifikan secara statistik terhadap Behavioral Intention dalam penggunaan teknologi smartphone untuk pembelajaran

H4a: Performance Expectancy diprediksi memiliki pengaruh langsung yang signifikan secara statistik terhadap Behavioral Intention dalam penggunaan teknologi smartphone untuk pembelajaran.

H4b: Performance Expectancy diprediksi memiliki pengaruh langsung yang signifikan secara statistik terhadap Satisfaction dalam penggunaan teknologi smartphone untuk pembelajaran

H5: Perceived Performance diprediksi memiliki pengaruh langsung yang signifikan secara statistik terhadap Satisfaction dalam penggunaan teknologi smartphone untuk pembelajaran.

H6: Satisfaction diprediksi memiliki pengaruh langsung yang signifikan secara statistik terhadap Behavioral Intention dalam penggunaan teknologi smartphone untuk pembelajaran.

Berdasarkan analisis korelasi dan analisis causal effect terbukti bahwa H1, H2, H3, H4a, dan H6 adalah "partially support" dan hanya dua hipotesis H4b dan H5 adalah "fully support".

Model adopsi teknologi media online entertain untuk generasi Z dan Y

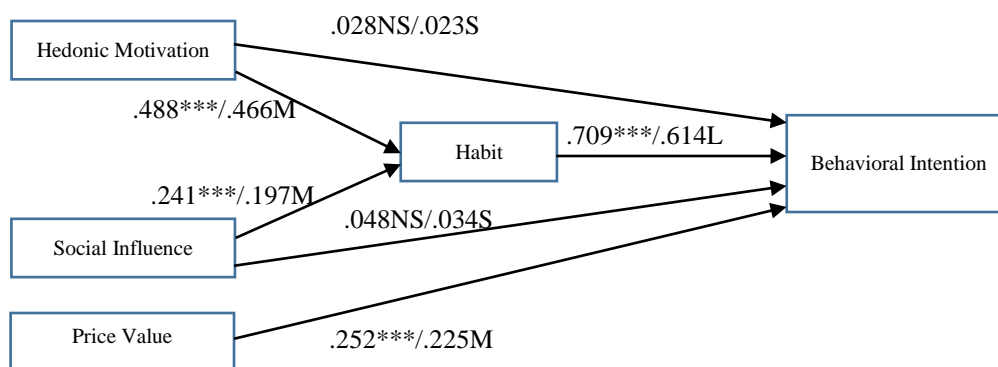

a) \*\*\* means  $p < 0.001$  and NS means not statistically significant at 0.05 level or less

b) S (Small), M (Medium), L (Large) standardized effects are those with magnitudes less than 0.1, 0.1 to less than 0.5, and equal to and more than 0.5, respectively.

Gambar 3 Model adopsi teknologi media online entertain untuk generasi Z dan Y

H1: Hedonic Motivation diprediksi memiliki pengaruh langsung yang signifikan secara statistik terhadap Behavioral Intention dalam penggunaan teknologi media online entertain.

H2: Hedonic Motivation diprediksi memiliki pengaruh langsung yang signifikan secara statistik terhadap Habit dalam penggunaan teknologi media online entertain.

H3: Habit diprediksi memiliki pengaruh langsung yang signifikan secara statistik terhadap Behavioral Intention dalam penggunaan teknologi media online entertain

H4: Social Influence diprediksi memiliki pengaruh langsung yang signifikan secara statistik terhadap Behavioral Intention dalam penggunaan teknologi media online entertain

H5: Social Influence diprediksi memiliki pengaruh langsung yang signifikan secara statistik terhadap Habit dalam penggunaan teknologi media online entertain.

H6: Price Value diprediksi memiliki pengaruh langsung yang signifikan secara statistik terhadap Behavioral Intention dalam penggunaan teknologi media online entertain.

Hasil Analisa Hipotesa:

Tabel 3. Hasil analisa model Adopsi Teknologi Aplikasi Media Hiburan Online

Research Hypotheses
Supported
H2: Hedonic Motivation memiliki pengaruh langsung yang signifikan secara statistik terhadap Habit.
H3: Habit memiliki pengaruh langsung yang signifikan secara statistik terhadap Behavioral Intention.
H5: Social Influence memiliki pengaruh langsung yang signifikan secara statistik terhadap Habit.
H6: Price Value memiliki pengaruh langsung yang signifikan secara statistik terhadap Behavioral Intention.
Partially Supported
H1: Hedonic Motivation memiliki pengaruh langsung yang signifikan secara statistik terhadap on Behavioral Intention.
H4: Social Influence memiliki pengaruh langsung yang signifikan secara statistik terhadap Behavioral Intention.

Hasil Analisa Moderating Effect Generasi Z dan Y:

Moderating effect generasi Z (925) and Y (196);

Tabel 4. Hasil analisa model Adopsi Teknologi Aplikasi Media Hiburan Online untuk generasi Z dan Y

Research Hypotheses	Comment	
Age sebagai "moderating effect"	Efek bagi Generasi Z	Efek bagi Generasi Y
Age tidak memiliki "moderating effect" yang signifikan pada pengaruh langsung Hedonic Motivation ke Habit	Medium, Positive, Statistically significant	Medium, Positive, Statistically significant
Age tidak memiliki "moderating effect" yang signifikan pada pengaruh langsung Social Influence ke Habit	Medium, Positive, Statistically significant	Medium, Positive, Not Statistically significant
Age memiliki "moderating effect" yang signifikan pada pengaruh langsung Habit ke Behavioral Intention	Large, Positive, Statistically significant	Large, Positive, Statistically significant
Age tidak memiliki "moderating effect" yang signifikan pada pengaruh langsung Hedonic Motivation ke Behavioral Intention	Small, Positive, Not Statistically significant	Small, Positive, Not Statistically significant
Age tidak memiliki "moderating effect" yang signifikan pada pengaruh langsung Price Value ke Behavioral Intention	Medium, Positive, Statistically significant	Medium, Positive, Not Statistically significant
Age tidak memiliki "moderating effect" yang signifikan pada pengaruh langsung Social influence ke Behavioral Intention	Small, Positive, Not Statistically significant	Medium, Positive, Not Statistically significant

**D. STATUS LUARAN:** Tuliskan jenis, identitas dan status ketercapaian setiap luaran wajib dan luaran tambahan (jika ada) yang dijanjikan. Jenis luaran dapat berupa publikasi, perolehan kekayaan intelektual, hasil pengujian atau luaran lainnya yang telah dijanjikan pada proposal. Uraian status luaran harus didukung dengan bukti kemajuan ketercapaian luaran sesuai dengan luaran yang dijanjikan. Lengkapi isian jenis luaran yang dijanjikan serta unggah bukti dokumen ketercapaian luaran wajib dan luaran tambahan melalui Simlitabmas.

Luaran HKI berupa scan sertifikat HKI dan scan sertifikat penyaji conference internasional terindex scopus ditampilkan dalam lampiran dengan deskripsi disajikan berikut ini:

1. Luaran HKI (Hak Kekayaan Intelektual)

Nomor dan Tanggal Permohonan : EC00201951092, 16 Agustus 2019

Nomor HKI : 000150732

Pencipta : FX. Hendra Prasetya, ST., MT, Bernardinus Harnadi, Ph.D., Albertus Dwi Yoga Widianoro, S.Kom, M.Kom.

Jenis Ciptaan : Karya Tulis (Artikel)

Judul Ciptaan : The Difference Adoption Of E-Commerce Technology Among Z And Y Generations

REPUBLIC INDONESIA  
KEMENTERIAN HUKUM DAN HAK ASASI MANUSIA

## SURAT PENCATATAN CIPTAAN

Dalam rangka pelaksanaan peraturan di bidang ilmu pengetahuan, seni dan sastra berdasarkan Undang-Undang Nomor 28 Tahun 2014 tentang Hak Cipta dengan ini memohonkan:

Nomor dan tanggal permohonan	: EC00201951092, 16 Agustus 2019
<b>Pencipta</b>	
Nama	: FX. Hendra Prasetya, ST, MT, Bernardinus Harnadi, Ph.D., dkk
Alamat	: Jl. Kipatong Barat IV/20 Padak Payang, Semarang, Jawa Tengah, 50235
Kewarganegaraan	: Indonesia
<b>Pemegang Hak Cipta</b>	
Nama	: LPPM Universitas Katolik Semarang
Alamat	: J. Pucyutan Lekar IV/1, Henda Dharur, Semarang, Jawa Tengah, 50231
Kewarganegaraan	: Indonesia
Jenis Ciptaan	: Karya Tulis (Artikel)
Judul Ciptaan	: The Difference Adoption Of E-Commerce Technology Among Z And Y Generations
Tanggal dan tempat ditemukannya untuk pertama kali di wilayah Indonesia atau di luar wilayah Indonesia	: 31 Juli 2019, di Semarang
Jangka waktu perlindungan	: Berlaku selama 35 (tiga puluh lima) tahun sejak Ciptaan tersebut pertama kali dilakukan Pengumuman.
Nomor pencatatan	: 000150732

adalah benar berdasarkan keterangan yang diberikan oleh Pemohon.  
Surat Pendaftaran Hak Cipta atau produk Hak terkait ini sesuai dengan Pasal 72 Undang-Undang Nomor 28 Tahun 2014 tentang Hak Cipta

q.r. MENTERI HUKUM DAN HAK ASASI MANUSIA  
DIREKTUR JENDERAL KEKAYAAN INTELEKTUAL



Dr. Freddy Harris, S.H., LL.M., ACCS  
NIP. 196611011994031001



Gambar 4 Luaran HKI

2. Artikel konferensi Internasional berindeks scopus

Konferens : The 23rd International Computer Science and Engineering Conference (ICSEC 2019), 30 Oktober - 1 November 2019, Patong, Phuket, Thailand

Artikel : The Difference Adoption Of E-Commerce Technology Among Z And Y Generations

Penyaji : Bernardinus Harnadi, Ph.D.

Abstrac-book : [https://www.icsec2019.org/file/ICSEC2019-Abstrac\\_Book.pdf](https://www.icsec2019.org/file/ICSEC2019-Abstrac_Book.pdf)



Gambar 5 Luanan Konferensi Internasional terindek scopus berupa sertifikat presentasi (The Difference Adoption of E-Commerce Technology among Z and Y Generations).

3. Artikel konferensi Internasional berindeks scopus

Konferens : The 23rd International Computer Science and Engineering Conference (ICSEC 2019), 30 Oktober - 1 November 2019, Patong, Phuket, Thailand

Artikel : Investigation of Adoption of Smartphone Technology for Learning

Penyaji : FX. Hendra Prasetya, ST., MT.

Abstrac-book : [https://www.icsec2019.org/file/ICSEC2019-Abstrac\\_Book.pdf](https://www.icsec2019.org/file/ICSEC2019-Abstrac_Book.pdf)



Gambar 6 Luaran Konferensi Internasional terindeks scopus berupa sertifikat presentasi (Investigasi of Adoption of Smartphone Technology for Learning)

#### 4. Draf artikel journal internasional

Judul draft artikel: The Role of Cultural Factors as Moderator on Acceptance of Online Media Entertain Technology

**E. PERAN MITRA:** Tuliskan realisasi kerjasama dan kontribusi Mitra baik *in-kind* maupun *in-cash* (untuk Penelitian Terapan, Penelitian Pengembangan, PTUPT, PPUPT serta KRUPPT). Bukti pendukung realisasi kerjasama dan realisasi kontribusi mitra dilaporkan sesuai dengan kondisi yang sebenarnya. Bukti dokumen realisasi kerjasama dengan Mitra diunggah melalui Simlitabmas.

Kerjasama Mitra:

Peran Mitra dalam penelitian ini, mitra akan menggunakan model (hasil penelitian) untuk digunakan sebagai model adopsi dari startup industri kreatif digital oleh Raxean Studio.

Kontribusi mitra: Penggunaan fasilitas Studio perusahaan Raxean Studio untuk implementasi aplikasi web dan android bagi pengembangan industri kreatif dalam penelitian (in kind).

**F. KENDALA PELAKSANAAN PENELITIAN:** Tuliskan kesulitan atau hambatan yang dihadapi selama melakukan penelitian dan mencapai luaran yang dijanjikan, termasuk penjelasan jika pelaksanaan penelitian dan luaran penelitian tidak sesuai dengan yang direncanakan atau dijanjikan.

Penelitian ini memiliki kendala dalam mengeneralisir model yang dihasilkan penelitian yang dapat digunakan bagi implementasi dan pengembangan industri kreatif digital secara umum. Dengan demikian model dapat diterapkan pada bidang area tertentu dalam industri kreatif digital seperti bidang e-commerce (belanja online dan transaksi keuangan), media online entertain (aplikasi games, musik, dan video) dan aplikasi pembelajaran via smartphone.



**G. RENCANA TAHAPAN SELANJUTNYA:** Tuliskan dan uraikan rencana penelitian di tahun berikutnya berdasarkan indikator luaran yang telah dicapai, rencana realisasi luaran wajib yang dijanjikan dan tambahan (jika ada) di tahun berikutnya serta *roadmap* penelitian keseluruhan. Pada bagian ini diperbolehkan untuk melengkapi penjelasan dari setiap tahapan dalam metoda yang akan direncanakan termasuk jadwal berkaitan dengan strategi untuk mencapai luaran seperti yang telah dijanjikan dalam proposal. Jika diperlukan, penjelasan dapat juga dilengkapi dengan gambar, tabel, diagram, serta pustaka yang relevan. Jika laporan kemajuan merupakan laporan pelaksanaan tahun terakhir, pada bagian ini dapat dituliskan rencana penyelesaian target yang belum tercapai.

Model yang dihasilkan dari penelitian tahun pertama ini selanjutnya akan digunakan untuk mensukseskan implementasi industri kreatif digital pada kegiatan penelitian tahun kedua yang menyasar generasi Z dan Y yang memiliki rentang usia masing-masing 15-19 tahun dan 20–24 tahun. Penelitian tahun kedua dimulai dengan mengkaji teori yang relevan yang dapat digunakan untuk merancang instrument penelitian dan digunakan untuk pengujian model oleh ketua dan anggota peneliti. Pengujian model dilakukan melalui FGD dan hasilnya digunakan untuk pengembangan sekaligus penyempurnaan website dan aplikasi potensi industri kreatif digital oleh ketua dan anggota 1. Hasilnya perlu direview kembali melalui FGD dengan para pakar dan pelaku industri kreatif oleh ketua dan anggota 2. Setelah penyempurnaan dirasa cukup maka dilakukan workshop pemanfaatan website dan aplikasi potensi industri kreatif secara luas oleh anggota peneliti sebelum dipasang pada server yang tepat dan diluncurkan ke masyarakat. Hasil implementasi pada tahun kedua ini dipublikasikan dalam seminar nasional, konferensi internasional, dan jurnal internasional oleh ketua dan anggota peneliti. Dari segi tingkat kesiapan teknologi penelitian tahun kedua berada pada TKT 6. Diagram yang menggambarkan tahapan penelitian berikutnya ditampilkan dalam Gambar 7.

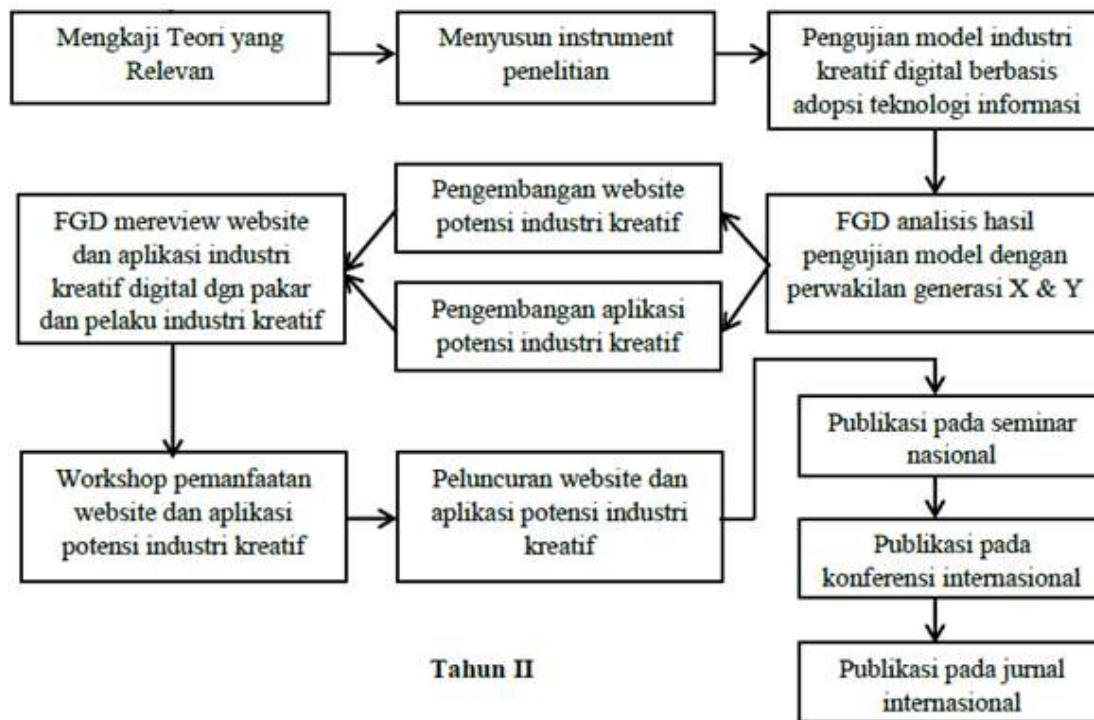

Gambar 7 Tahapan penelitian tahun ke II

Tabel 5 menyajikan rencana target capaian tahun II penelitian.

Tabel 6 Rencana Target Capaian Tahun II

No	Jenis Luaran				Indikator Capaian
	Kategori	Sub Kategori	Wajib	Tambahan	2020
1.	Artikel ilmiah dimuat di jurnal	Internasional bereputasi		√	√
		Nasional Terakreditasi			
2.	Artikel ilmiah dimuat di prosiding	Internasional Terindeks		√	√
		Nasional		√	√
3.	HKI	Hak Cipta		√	
4.	Model/Purwarupa/Desain/Karya seni/Rekayasa Sosial		√		√
5.	Tingkat Kesiapan Teknologi (TKT)				Skala 6

**H. DAFTAR PUSTAKA:** Penyusunan Daftar Pustaka berdasarkan sistem nomor sesuai dengan urutan pengutipan. Hanya pustaka yang disitasi pada laporan kemajuan yang dicantumkan dalam Daftar Pustaka.

1. Bekraf-BPS Indonesia, "Data Statistik dan Hasil Survei Ekonomi Kreatif 2017," retrieved from [http://www.bekraf.go.id/downloadable/pdf\\_file/170475-data-statistik-dan-hasil-survei-ekonomi-kreatif.pdf](http://www.bekraf.go.id/downloadable/pdf_file/170475-data-statistik-dan-hasil-survei-ekonomi-kreatif.pdf), accessed: 27-3-2018.
2. Fetry Wuryasti, "Tumbuh 10 Persen, Generasi Milineal Dongkrak Industri Digital," E-paper Media Indonesia, retrieved from <http://mediaindonesia.com/read/detail/136960-tumbuh-10-persen-generasi-milineal-dongkrak-industri-digital>, accessed: 27-3-2018.
3. Widyanita, "Potensi Ekonomi Digital Indonesia," infografik katadata, available at <https://katadata.co.id/infografik/2016/11/18/potensi-ekonomi-digital-indonesia>, accessed 27-3-2018.
4. Demographic Trends - Centennial Infographic, "The Centennials: Introducing a New Generation of Youth," retrieved from [http://tfcfiles.com/Marketing/Images/Infographics/KantarFutures-Centennial\\_Infographic-2017.pdf](http://tfcfiles.com/Marketing/Images/Infographics/KantarFutures-Centennial_Infographic-2017.pdf), accessed: 19-11-2017.
5. Pew Research Center, "Millennial," available at <http://www.pewresearch.org/topics/millennials/>, accessed: 19-11-2017.
6. B. Harnadi, "An investigation of the adoption of online game technologies in Indonesia," International Journal of Gaming and Computer-Mediated Simulations, vol.9, issue 1, pp. 1–27, 2017.
7. L. Fan, C. G. Ghu, Y. H. Suh, and S. C. Lee, "How to attract Chinese online game users," Asian journal on quality, vol. 13, no. 1, pp. 7–21, 2012.
8. P. Chaitaneeyachat, "The adoption of online game technologies in Thailand," doctoral dissertation in Information Technology, Assumption University, 2012.
9. H. Y. Wang and Y. S. Wang, "Gender differences in the perception and acceptance of online games," British Journal of Educational Technology, vol. 39, no. 5, pp. 787–806, 2008.
10. M. C. Lee, "Understanding the behavioural intention to play online games," Online Information Review, 33(5), 849–872, 2009.
11. L. S. L. Chen, C. J. Kuan, Y. H. Lee, & H. L. Huang, "Applicability of the UTAUT Model in Playing Online Game through Mobile Phones: Moderating Effects of User Experience," Proceedings of the 2011 IEEE International Technology Management Conference (ITMC) (pp. 625-629), 2011.

12. B. Hernández, J. Jiménez, & M. J. Martín, "Age, gender and income: Do they really moderate online shopping behaviour?," *Online Information Review*, 35(1), 113–133, 2011.
13. W. S. Kwon, & M. Noh, "The influence of prior experience and age on mature consumers perceptions and intentions of internet apparel shopping," *Journal of Fashion Marketing and Management: An International Journal*, 14(3), 335–349, 2010.
14. Venkatesh, V., Thong, J. Y. L., & Xu, X. (2012). Extending the Unified Theory of Acceptance and Use of Technology, *MIS Quarterly*, 36(1), 157–178.
15. A. D. Widiatoro, R. Sanjaya, T. Rahardjo and R. Djati, "Review on the application of financial technology for the Wayang Orang Ngesti Pandowo cultural creative industry," 2017 4th International Conference on Information Technology, Computer, and Electrical Engineering (ICITACEE), Semarang, pp. 225-229, 2017.
16. B. Harnadi, "Investigasi Adopsi Teknologi Sosial Media," research report, Soegijapranata Catholic University, 2018.
17. S. K. Sharma and M. Sharma, "Examining the role of trust and quality dimensions in the actual usage of mobile banking services: An empirical investigation," *International Journal of Information Management*, vol. 44, pp. 65-75, 2019.
18. A. M. Baabdullah, A. A. Alalwan, N. P. Rana, H. Kizgin, P. Patil, "Consumer use of mobile banking (M-Banking) in Saudi Arabia: Towards an integrated model," *International Journal of Information Management*, vol. 44, pp. Pages 38-52, 2019.
19. M. A. Shareef, A. Baabdullah, S. Dutta, V. Kumar, Y. K. Dwivedi, "Consumer adoption of mobile banking services: An empirical examination of factors according to adoption stages," *Journal of Retailing and Consumer Services*, vol. 43, 2018.
20. S. F. Verkijika, "Factors influencing the adoption of mobile commerce applications in Cameroon," *Telematics and Informatics*, Vol. 35, Issue 6, pp. 1665-1674, 2018.
21. H. R. Marriott, M. D. Williams, "Exploring consumers perceived risk and trust for mobile shopping: A theoretical framework and empirical study," *Journal of Retailing and Consumer Services*, vol. 42, pp. 133-146, 2018.
22. S. Agrebi, J. Jallais, "Explain the intention to use smartphones for mobile shopping, *Journal of Retailing and Consumer Services*," vol. 22, pp. 16-23, 2015.
23. A. A. Alalwan, Y. K. Dwivedi, N. P. Rana, "Factors influencing adoption of mobile banking by Jordanian bank customers: Extending UTAUT2 with trust," *International Journal of Information Management*, vol. 37, Issue 3, pp. 99-110, 2017.
24. F. M-Leiva, S. C-Climent, F. L-Cabanillas, "Determinants of intention to use the mobile banking apps: An extension of the classic TAM model," *Spanish Journal of Marketing - ESIC*, vol. 21, Issue 1, pp. 25-38, 2017.
25. M. N. Masrek, I. S. Mohamed, N. M. Daud, N. Omar, "Technology Trust and Mobile Banking Satisfaction: A Case of Malaysian Consumers," *Procedia - Social and Behavioral Sciences*, vol. 129, pp. 53-58, 2014.
26. A. A. Alalwan, Y. K. Dwivedi, N. P. Rana, R. Algharabat, "Examining factors influencing Jordanian customers' intentions and adoption of internet banking: Extending UTAUT2 with risk," *Journal of Retailing and Consumer Services*, vol. 40, pp.125-138, 2018.
27. P. K. Chopdar, N. Korfiatis, VJ. Sivakumar, and M. D. Lytras, "Mobile shopping apps adoption and perceived risks: A cross-country perspective utilizing the Unified Theory of Acceptance and Use of Technology," *Computers in Human Behaviour*, vol. 86, pp. 109-128, 2018.

28. W. Boonsiritomachai, K. Pitchayadejanant, "Determinants affecting mobile banking adoption by generation Y based on the Unified Theory of Acceptance and Use of Technology Model modified by the Technology Acceptance Model concept," *Kasetsart Journal of Social Sciences*, 2017.
29. F. D. Davis, "Perceived Usefulness, Perceived Ease of Use, and User Acceptance of Information Technology," *Management Information Systems Quarterly*, vol. 13, no. 3, pp. 319–340, 1989.
30. V. Venkatesh, M. G. Morris, G. B. Davis, and F. D. Davis, "User acceptance of information technology: toward a Unified View," *MIS Quarterly*, vol. 27, no. 3, pp. 425–479, 2003.
31. C. Martins, T. Oliveira, A. Popovič, "Understanding the Internet banking adoption: A unified theory of acceptance and use of technology and perceived risk application," *International Journal of Information Management*, vol. 34, Issue 1, pp. 1-13, 2014.
32. K. A. Alshare, and Abeer A. Mousa, "The Moderating Effect of Espoused Cultural Dimensions on Consumer's Intention to Use Mobile Payment Devices," *Thirty Fifth International Conference on Information Systems*, Auckland, pp. 1-15 , 2014.
33. T. Zhou, Y. Lu, B. Wang, "Integrating TTF and UTAUT to explain mobile banking user adoption," *Computers in Human Behavior*, vol 26, Issue 4, pp. 760-767, 2010.
34. B. Hernández, J. Jiménez, and M. J. Martín, "Age, gender and income: Do they really moderate online shopping behaviour?" *Online Information Review*, vol. 35, no. 1, pp. 113–133, 2011.
35. Ali Tarhini, Kate Hone, Xiaohui Liu & Takwa Tarhini, "Examining the moderating effect of individuallevel cultural values on users' acceptance of Elearning in developing countries: a structural equation modeling of an extended technology acceptance model", *Interactive Learning Environments*, <http://dx.doi.org/10.1080/10494820.2015.1122635>, 2016.
36. Hyo-Jung Kim, Jin-Myong Lee, Jong-Youn Rha, "Understanding the role of user resistance on mobile learning usage among university students", *Computers & Education*, vol. 113, pp. 108-118, <http://dx.doi.org/10.1016/j.compedu.2017.05.015>, 2017.
37. Akbar, F., "Investigating students' acceptance an use of technology in academic environment", : <http://repository.cmu.edu/hsshonors>, 2013.
38. Ali Abdallah Alalwan, Abdullah Baabdullah, Nripendra P. Rana, Kuttimani Tamilmani, Yogesh K. Dwivedi, "Examining adoption of mobile internet in Saudi Arabia: Extending TAM with perceived enjoyment, innovativeness and trust", *Technology in Society*, doi: 10.1016/j.techsoc.2018.06.007, 2018.
39. Joo & Sang, "Exploring Koreans' smartphone usage: An integrated model of the technology acceptance model and uses and gratifications theory", *Computers in Human Behavior*, vol. 29, pp. 2512-2518, <http://dx.doi.org/10.1016/j.chb.2013.06.002>, 2013.
40. Brahim Hadji Ing, Patrice Degoulet, "Information System End-user Satisfaction and Continuance Intention: a Unified Modeling Approach", *Journal of Biomedical Informatics*, doi: <http://dx.doi.org/10.1016/j.jbi.2016.03.021>, 2016.
41. H. Hamidi, A. Chavoshi, "Analysis of the essential factors for the adoption of mobile learning in higher education: A case study of students of the University of Technology", *Telematics and Informatics*, vol. 35, pp. 1053-1070, <http://dx.doi.org/10.1016/j.tele.2017.09.016>, 2017.
42. Amer Al- Adwan, Ahmad Al- Adwan, Jo Smedley , "Exploring students acceptance of e-learning using Technology Acceptance Model in Jordanian universities," *International Journal of Education and Development using Information and Communication Technology (IJEDICT)*, Vol. 9, Issue 2, pp. 4-18, 2013.
43. Gokhan Da ghan, Buket Akkoyunlu, "Modeling the continuance usage intention of online learning environments", *Computers in Human Behavior*, vol. 60, pp. 198-211,

<http://dx.doi.org/10.1016/j.chb.2016.02.066>, 2017.

44. Apollos Patricks Oghuma, Christian Fernando Libaque-Saenz, Siew Fan Wong, Younghoon Chang, "An expectation-confirmation model of continuance intention to use mobile instant messaging", *Telematics and Informatics*, vol. 33, pp. 34-47, 2016.
45. Zixiu Guoa, Lin Xiaob, Christine Van Toorna, Yihong Laia, Chanyoung Seoa, "Promoting Online Learners' Continuance Intention: An Integrated Flow Framework", *Information and Management*, <http://dx.doi.org/10.1016/j.im.2015.10.010>, 2016.
46. Wing S. Chow, Si Shi, "Investigating Students' Satisfaction And Continuance Intention Toward E-Learning: An Extension Of The Expectation-Confirmation Model", *Procedia - Social and Behavioral Sciences*, vol. 141, pp. 1145-1149, <http://creativecommons.org/licenses/by-nc-nd/3.0/>, 2014.
47. P. S. Wei, & H. P. Lu, "Why do people play mobile social games? An examination of network externalities and of uses and gratifications," *Internet Research*, 24(3), 313-33, 2014.. doi:10.1108/IntR-04-2013-0082.
48. M.M. Luo, S. Chea, and J.-S. Chen, "Web-based information service adoption: A comparison of the motivational model and the uses and gratifications theory," *Decision Support Systems*, vol. 51, pp. 21-30, 2011.
49. D. M. Koo, "The moderating role of locus of control on the links between experiential motives and intention to play online games. *Computers in Human Behavior*, 25(2), 466-474, 2009.
50. M. C. Lee, "Understanding the behavioural intention to play online games," *Online Information Review*, 33(5), 849-872, 2009. doi:10.1108/14684520911001873.
51. Fan, L., Ghu, C. G., Suh, Y. H., & Lee, S. C., "How to attract Chinese online game users," *Asian Journal on Quality*, 13(1), 7-2, 2012.. doi:10.1108/15982681211237798.
52. J. Merikivi, V. Tuunainen V. & N. Duyen, "What makes continued mobile gaming enjoyable?," *Computers in Human Behavior*, 2017, doi: 10.1016/j.chb.2016.11.070.
53. H. Khatimah, P. Susanto, and N. L. Abdullah, "Hedonic Motivation and Social Influence on Behavioral Intention of E-Money: The Role of Payment Habit as a Mediator," *International Journal of Entrepreneurship*, Vol. 23 Issue 1, pp. 1-9, 2019.
54. Q. Wang and X. Sun, "Investigating gameplay intention of the elderly using an Extended Technology Acceptance Model (ETAM)," *Technological Forecasting & Social Change*, 2016.
55. C.-P. Chen, "Understanding mobile English-learning gaming adopters in the self-learning market: The Uses and Gratification Expectancy Model," *Computers & Education*, vol. 126, pp 217-230, 2018.

Dokumen pendukung luaran Wajib #1

Luaran dijanjikan: Model

Target: produk

Dicapai: Produk

Dokumen wajib diunggah:

1. Deskripsi dan spesifikasi model
2. Hasil uji pakar/publik terakhir
3. Dokumentasi (foto) pengujian model

Dokumen sudah diunggah:

1. Deskripsi dan spesifikasi model
2. Hasil uji pakar/publik terakhir
3. Dokumentasi (foto) pengujian model

Dokumen belum diunggah:

-

**MODEL DAN IMPLEMENTASI INDUSTRI KREATIF DIGITAL BERBASIS ADOPSI  
TEKNOLOGI INFORMASI GENERASI Y DAN Z**

**Luaran Wajib Penelitian: Model Adopsi Teknologi Informasi Generasi Y dan Z**

- I. Model adopsi teknologi E-Commerce pada generasi Y dan Z**
- II. Model adopsi teknologi Media Online Entertain pada generasi Y dan Z**
- III. Model adopsi teknologi smartphone untuk pembelajaran**

**Uraian Luaran:**

Luaran wajib penelitian berupa model adopsi teknologi informasi pada generasi Z dan Y yang terbagi pada teknologi E-Commerce (bisnis dan keuangan) dan teknologi media online entertain serta model adopsi smartphone untuk pembelajaran. Model dihasilkan dengan menganalisis dan mengevaluasi model adopsi tersebut pada generasi Z dan Y. Model adopsi teknologi informasi yang dihasilkan ini akan digunakan untuk masukan bagi implementasi industri kreatif digital berbasis adopsi teknologi informasi generasi Z dan Y.

**Peneliti:**

Ketua : Dr. Bernardinus Harnadi, S.T., M.T.

Anggota1 : Albertus Dwiyoga W., S.Kom., M.Kom

Anggota2 : FX. Hendra Prasetya, S.T., M.T

**Universitas Katolik Soegijapranata**

**Semarang**

**2019**

## I. Model Adopsi Teknologi E-Commerce generasi Y dan Z

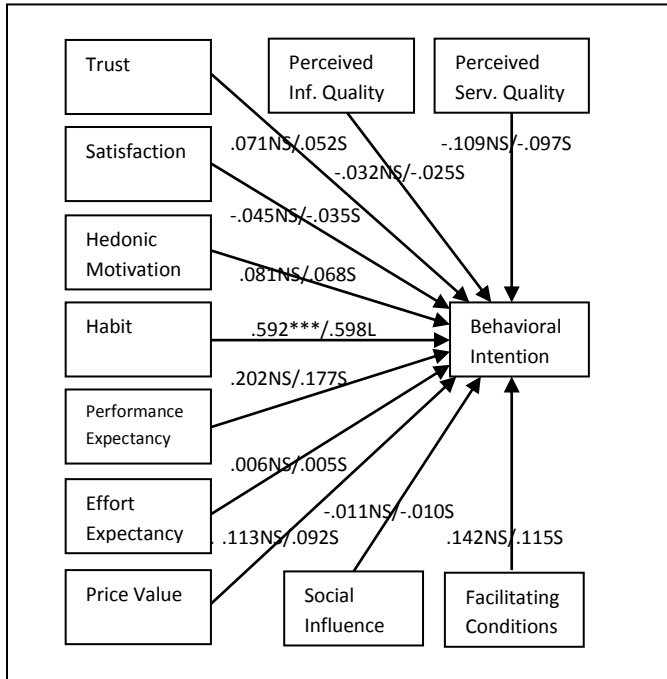

Gambar 1. Model adopsi teknologi E-commerce

H1: Perceived Information Quality (IQ) diprediksi memiliki pengaruh langsung yang signifikan secara statistik terhadap Behavioral Intention untuk menggunakan teknologi e-commerce.

H2: Perceived Service Quality (SQ) diprediksi memiliki pengaruh langsung yang signifikan secara statistik terhadap Behavioral Intention untuk menggunakan teknologi e-commerce.

H3: Trust (TR) diprediksi memiliki pengaruh langsung yang signifikan secara statistik terhadap Behavioral Intention untuk menggunakan teknologi e-commerce.

H4: Satisfaction (SF) diprediksi memiliki pengaruh langsung yang signifikan secara statistik terhadap Behavioral Intention untuk menggunakan teknologi e-commerce..

H5: Hedonic Motivation (HM) diprediksi memiliki pengaruh langsung yang signifikan secara statistik terhadap Behavioral Intention untuk menggunakan teknologi e-commerce.

H6: Performance Expectancy (PE) diprediksi memiliki pengaruh langsung yang signifikan secara statistik terhadap Behavioral Intention untuk menggunakan teknologi e-commerce.

H7: Effort Expectancy (EE) diprediksi memiliki pengaruh langsung yang signifikan secara statistik terhadap Behavioral Intention untuk menggunakan teknologi e-commerce.

H8: Price Value (PV) diprediksi memiliki pengaruh langsung yang signifikan secara statistik terhadap Behavioral Intention untuk menggunakan teknologi e-commerce.

H9: Facilitating Conditions (FC) diprediksi memiliki pengaruh langsung yang signifikan secara statistik terhadap Behavioral Intention untuk menggunakan teknologi e-commerce..

H10: Social Influence (SI) diprediksi memiliki pengaruh langsung yang signifikan secara statistik terhadap Behavioral Intention untuk menggunakan teknologi e-commerce..

H11: Habit (HB) diprediksi memiliki pengaruh langsung yang signifikan secara statistik terhadap Behavioral Intention untuk menggunakan teknologi e-commerce.



### A. Hasil Analisis Korelasi Variabel dari Model:

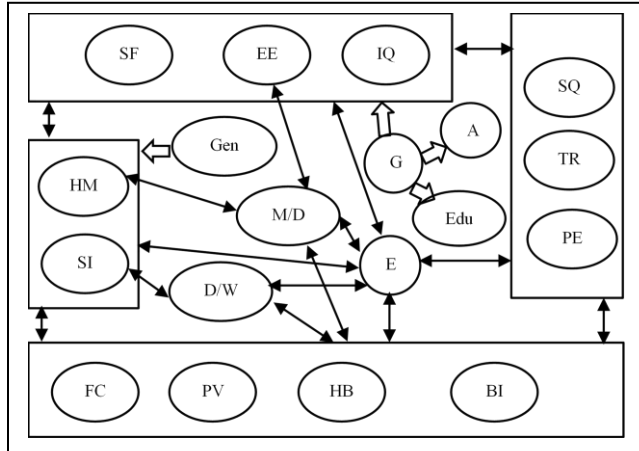

Gambar 2. Model Korelasi Antar Variabel dalam model

#### **Hasil Analisis:**

1. Terdapat korelasi positif antara variabel: Effort Expectancy, Satisfaction, Perceived Information Quality, Perceived Service Quality, Trust, Performance Expectancy, Hedonic Motivation, Social Influence, Facilitating Conditions, Habit, Price Value, dan Behavioral Intention.
2. Individu yang lebih berpengalaman akan merasa lebih: mudah, terpuaskan, percaya mendapatkan informasi dengan kualitas layanan tertentu, percayaan, terbantu dalam memperoleh keuntungan pribadi, terhibur, dipengaruhi oleh teman dan keluarga, percaya bahwa infrastruktur teknis yang mereka miliki dapat mendukung mereka, terbiasa, dapat menerima harga, dan merasa berniat dalam menggunakan teknologi e-commerce. Individu yang lebih berpengalaman juga lebih banyak menghabiskan waktu dalam menggunakan teknologi e-commerce.
3. Individu dengan tingkat pengaruh sosial dari lingkungan yang tinggi dalam menggunakan e-commerce menghabiskan waktu lebih banyak dalam menggunakan teknologi e-commerce.
4. Variabel Effort Expectancy, Satisfaction, Perceived Information Quality dan Age memiliki perbedaan yang signifikan dalam hal gender. Ini berarti bahwa pria dan wanita memiliki perbedaan persepsi dalam hal: kemudahan dalam menggunakan e-commerce, merasa puas, persepsi dalam menemukan informasi tertentu, dan usia dalam menggunakan teknologi e-commerce.

5. Perbedaan yang signifikan dalam konteks gender ditemukan dalam Sastifaction, Effort Expectancy, Information Quality, Age, dan Education. Ini berarti bahwa pria banyak yang lebih tua dan memiliki pendidikan yang lebih tinggi dibanding wanita dalam penelitian ini. Selain itu, pria kurang merasa puas dan menemukan lebih banyak kesulitan dalam menggunakan teknologi e-commerce dan kurang bisa mendapatkan informasi dengan kualitas yang lebih baik dibanding wanita.
6. Perbedaan signifikan pada generasi Z dan Y di mana ditemukan pada Hedonic Motivation dan Social Influence dan bukan pada yang lain. Ini berarti bahwa generasi Z kurang memiliki motivasi hedonis dan kurang dipengaruhi oleh teman dan keluarga dalam menggunakan e-commerce daripada generasi Y.

### B. Hasil Analisis Hipotesa:

Hasil analisa hipotesa menyatakan bahwa H1, H2, H3, H4, H5, H6, H7, H8, H9, dan H10 adalah “partially support“ dan H11 “fully support.”

### C. Perbedan Adopsi Teknologi E-Commerce Technology antara generasi Z and Y

Tabel 1. Hasil analisis perbedaan adopsi antara generasi Z dan Y

Effect	Z generation (N = 248)				Y generation (N =95)			
	Unstandardized Estimate	Statistical Significance	Standardized Estimate	Magnitude	Unstandardized Estimate	Statistical Significance	Standardized Estimate	Magnitude
IQ→ BI	-.084	NS	-.071	S	-.023	NS	-.017	S
SQ→ BI	-.112	NS	-.107	M	-.082	NS	-.060	S
TR→ BI	.042	NS	.034	S	.162	NS	.092	S
SF→ BI	-.021	NS	-.016	S	-.043	NS	-.033	S
HM→ BI	-.042	NS	-.040	S	.449	NS	.264	M
HB→ BI	.611	***	.647	L	.703	***	.627	L
PE→ BI	.254	NS	.217	M	.106	NS	.097	S
EE→ BI	.005	NS	.004	S	-.074	NS	-.063	S
PV→ BI	.216	NS	.189	M	-.147	NS	-.103	M
SI→ BI	-.046	NS	-.045	S	.045	NS	.034	S
FC→ BI	.164	NS	.136	M	.164	NS	.126	M

Note: \*\*\* indicate statistical significance at a level of 0.001 and NS indicates not statistically significant at a level of 0.05 or less.

## II. Model Adopsi Teknologi Aplikasi Media Online Entertain generasi Y dan Z

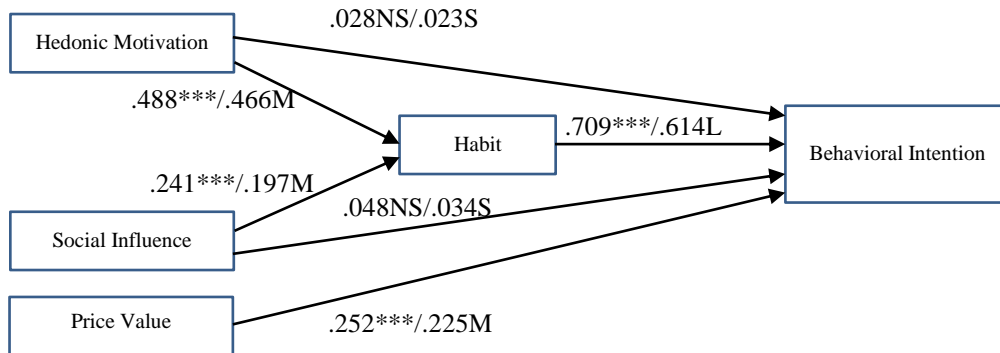

a) \*\*\* means  $p < 0.001$  and NS means not statistically significant at 0.05 level or less

b) S (Small), M (Medium), L (Large) standardized effects are those with magnitudes less than 0.1, 0.1 to less than 0.5, and equal to and more than 0.5, respectively.

Gambar 3. Model adopsi teknologi media online entertain

H1: Hedonic Motivation diprediksi memiliki pengaruh langsung yang signifikan secara statistik terhadap Behavioral Intention dalam penggunaan teknologi media online entertain.
H2: Hedonic Motivation diprediksi memiliki pengaruh langsung yang signifikan secara statistik terhadap Habit dalam penggunaan teknologi media online entertain.
H3: Habit diprediksi memiliki pengaruh langsung yang signifikan secara statistik terhadap Behavioral Intention dalam penggunaan teknologi media online entertain
H4: Social Influence diprediksi memiliki pengaruh langsung yang signifikan secara statistik terhadap Behavioral Intention dalam penggunaan teknologi media online entertain
H5: Social Influence diprediksi memiliki pengaruh langsung yang signifikan secara statistik terhadap Habit dalam penggunaan teknologi media online entertain.
H6: Price Value diprediksi memiliki pengaruh langsung yang signifikan secara statistik terhadap Behavioral Intention dalam penggunaan teknologi media online entertain.

### **Hasil Analisa Hipotesa:**

Tabel 2. Hasil analisa model Adopsi teknologi media online entertain

Research Hypotheses	Reference
<b>Supported</b>	
H2: Hedonic Motivation memiliki pengaruh langsung yang signifikan secara statistik terhadap Habit.	Khatimah (2019)[14]
H3: Habit memiliki pengaruh langsung yang signifikan secara statistik terhadap Behavioral Intention.	Khatimah (2019)[14], Chopdar (2018)[15], and Venkatesh (2012)[3]
H5: Social Influence memiliki pengaruh langsung yang signifikan secara statistik terhadap Habit.	Khatimah (2019)[14]
H6: Price Value memiliki pengaruh langsung yang signifikan secara statistik terhadap Behavioral Intention.	Chopdar (2018)[15], Alalwan (2018)[16], Alalwan (2017)[?], and Venkatesh (2012)[3]

<b>Partially Supported</b>	
H1: Hedonic Motivation memiliki pengaruh langsung yang signifikan secara statistik terhadap on Behavioral Intention.	Harnadi (2017)[4], Koo (2009)[20], and Lee (2009)[10]
H4: Social Influence memiliki pengaruh langsung yang signifikan secara statistik terhadap Behavioral Intention.	Wang & Sun (2016)[7], Fan et al. (2012)[9], Venkatesh (2012)[3], Koo (2009)[20], and Lee (2009)[10]

**Hasil Analisa Moderating Effect Generasi Z dan Y:**

Moderating effect generasi Z (925) and Y (196);

Tabel 3. Hasil analisa Moderating Effect Generasi Z dan Y

<b>Research Hypotheses</b>	<b>Comment</b>	
	<b>Effect for Z Generation</b>	<b>Effect for Y Generation</b>
Age as moderating effect		
Age sebagai "moderating effect"	Medium, Positive, Statistically significant	Medium, Positive, Statistically significant
Age tidak memiliki "moderating effect" yang signifikan pada pengaruh langsung Hedonic Motivation ke Habit	Medium, Positive, Statistically significant	Medium, Positive, Not Statistically significant
Age tidak memiliki "moderating effect" yang signifikan pada pengaruh langsung Social Influence ke Habit	Large, Positive, Statistically significant	Large, Positive, Statistically significant
Age memiliki "moderating effect" yang signifikan pada pengaruh langsung Habit ke Behavioral Intention	Small, Positive, Not Statistically significant	Small, Positive, Not Statistically significant
Age tidak memiliki "moderating effect" yang signifikan pada pengaruh langsung Hedonic Motivation ke Behavioral Intention	Medium, Positive, Statistically significant	Medium, Positive, Not Statistically significant
Age tidak memiliki "moderating effect" yang signifikan pada pengaruh langsung Price Value ke Behavioral Intention	Small, Positive, Not Statistically significant	Medium, Positive, Not Statistically significant

Dari hasil analisis dapat ditarik kesimpulan, bahwa:

1. Variabel Hedonic Motivation dan Social Influence memiliki pengaruh yang signifikan terhadap Kebiasaan dalam menggunakan media online entertain yang pada akhirnya menentukan tingkat adopsi teknologi tersebut.
2. Variabel berikutnya yang mempengaruhi tingkat adopsi media online entertain adalah Price Value.
3. Dari analisis, perbedaan antara kedua generasi Z dan Y dalam mengadopsi media online entertain lebih ditentukan oleh kebiasaan mereka dalam menggunakan media online entertain.

### III. Model adopsi teknologi smartphone untuk pembelajaran

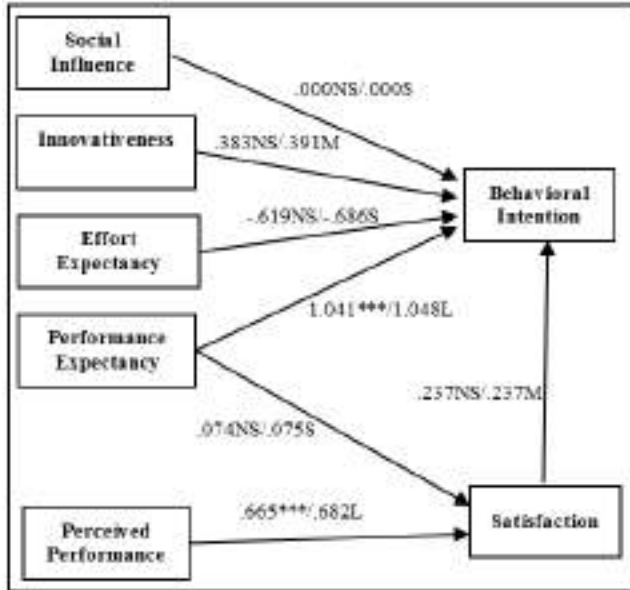

Gambar 4. Model adopsi teknologi smartphone untuk pembelajaran

H1: Social Influence diprediksi memiliki pengaruh langsung yang signifikan secara statistik terhadap Behavioral Intention dalam penggunaan teknologi smartphone untuk pembelajaran
H2: Innovativeness diprediksi memiliki pengaruh langsung yang signifikan secara statistik terhadap Behavioral Intention dalam penggunaan teknologi smartphone untuk pembelajaran
H3: Effort Expectancy diprediksi memiliki pengaruh langsung yang signifikan secara statistik terhadap Behavioral Intention dalam penggunaan teknologi smartphone untuk pembelajaran
H4a: Performance Expectancy diprediksi memiliki pengaruh langsung yang signifikan secara statistik terhadap Behavioral Intention dalam penggunaan teknologi smartphone untuk pembelajaran.
H4b: Performance Expectancy diprediksi memiliki pengaruh langsung yang signifikan secara statistik terhadap Satisfaction dalam penggunaan teknologi smartphone untuk pembelajaran
H5: Perceived Performance diprediksi memiliki pengaruh langsung yang signifikan secara statistik terhadap Satisfaction dalam penggunaan teknologi smartphone untuk pembelajaran.
H6: Satisfaction diprediksi memiliki pengaruh langsung yang signifikan secara statistik terhadap Behavioral Intention dalam penggunaan teknologi smartphone untuk pembelajaran.

Berdasarkan analisa korelasi dan analisa *causal effect* terbukti bahwa H1, H2, H3, H4a, dan H6 adalah “partially support” dan hanya dua hipotesa H4b dan H5 adalah “fully support”.

1. Dari analisis, dapat ditarik kesimpulan bahwa responden dalam penelitian ini yaitu mahasiswa perguruan tinggi akan lebih dapat mengadopsi smartphone untuk pembelajaran bila mereka merasakan manfaat langsung dari penggunaan smartphone untuk pembelajaran.
2. Mahasiswa akan merasa puas dalam menggunakan smartphone untuk pembelajaran bila mereka telah membuktikan bahwa smartphone yang mereka pergunakan benar-benar dapat membantu mereka belajar.

**MODEL DAN IMPLEMENTASI INDUSTRI KREATIF DIGITAL BERBASIS ADOPSI  
TEKNOLOGI INFORMASI GENERASI Y DAN Z**

**Luaran Wajib Penelitian: Model Adopsi Teknologi Informasi Generasi Y dan Z**

- I. Model adopsi teknologi E-Commerce pada generasi Y dan Z**
- II. Model adopsi teknologi Media Online Entertain pada generasi Y dan Z**
- III. Model adopsi teknologi smartphone untuk pembelajaran**

**Uraian Luaran:**

Luaran wajib penelitian berupa model adopsi teknologi informasi pada generasi Z dan Y yang terbagi pada teknologi E-Commerce (bisnis dan keuangan) dan teknologi media online entertain serta model adopsi smartphone untuk pembelajaran. Model dihasilkan dengan menganalisis dan mengevaluasi model adopsi tersebut pada generasi Z dan Y. Model adopsi teknologi informasi yang dihasilkan ini akan digunakan untuk masukan bagi implementasi industri kreatif digital berbasis adopsi teknologi informasi generasi Z dan Y.

**Peneliti:**

Ketua : Dr. Bernardinus Harnadi, S.T., M.T.

Anggota1 : Albertus Dwiyoga W., S.Kom., M.Kom

Anggota2 : FX. Hendra Prasetya, S.T., M.T

**Universitas Katolik Soegijapranata**

**Semarang**

**2019**

## I. Model Adopsi Teknologi E-Commerce generasi Y dan Z

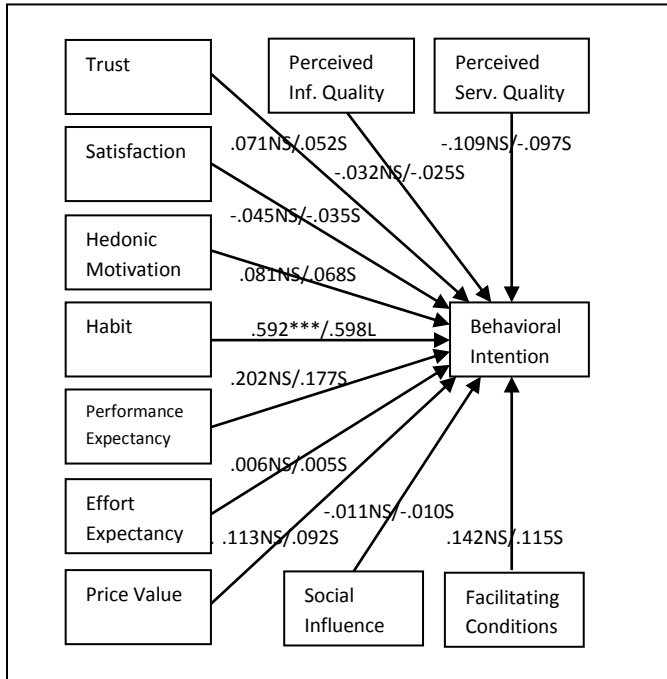

Gambar 1. Model adopsi teknologi E-commerce

H1: Perceived Information Quality (IQ) diprediksi memiliki pengaruh langsung yang signifikan secara statistik terhadap Behavioral Intention untuk menggunakan teknologi e-commerce.

H2: Perceived Service Quality (SQ) diprediksi memiliki pengaruh langsung yang signifikan secara statistik terhadap Behavioral Intention untuk menggunakan teknologi e-commerce.

H3: Trust (TR) diprediksi memiliki pengaruh langsung yang signifikan secara statistik terhadap Behavioral Intention untuk menggunakan teknologi e-commerce.

H4: Satisfaction (SF) diprediksi memiliki pengaruh langsung yang signifikan secara statistik terhadap Behavioral Intention untuk menggunakan teknologi e-commerce..

H5: Hedonic Motivation (HM) diprediksi memiliki pengaruh langsung yang signifikan secara statistik terhadap Behavioral Intention untuk menggunakan teknologi e-commerce.

H6: Performance Expectancy (PE) diprediksi memiliki pengaruh langsung yang signifikan secara statistik terhadap Behavioral Intention untuk menggunakan teknologi e-commerce.

H7: Effort Expectancy (EE) diprediksi memiliki pengaruh langsung yang signifikan secara statistik terhadap Behavioral Intention untuk menggunakan teknologi e-commerce.

H8: Price Value (PV) diprediksi memiliki pengaruh langsung yang signifikan secara statistik terhadap Behavioral Intention untuk menggunakan teknologi e-commerce.

H9: Facilitating Conditions (FC) diprediksi memiliki pengaruh langsung yang signifikan secara statistik terhadap Behavioral Intention untuk menggunakan teknologi e-commerce..

H10: Social Influence (SI) diprediksi memiliki pengaruh langsung yang signifikan secara statistik terhadap Behavioral Intention untuk menggunakan teknologi e-commerce..

H11: Habit (HB) diprediksi memiliki pengaruh langsung yang signifikan secara statistik terhadap Behavioral Intention untuk menggunakan teknologi e-commerce.



### A. Hasil Analisis Korelasi Variabel dari Model:

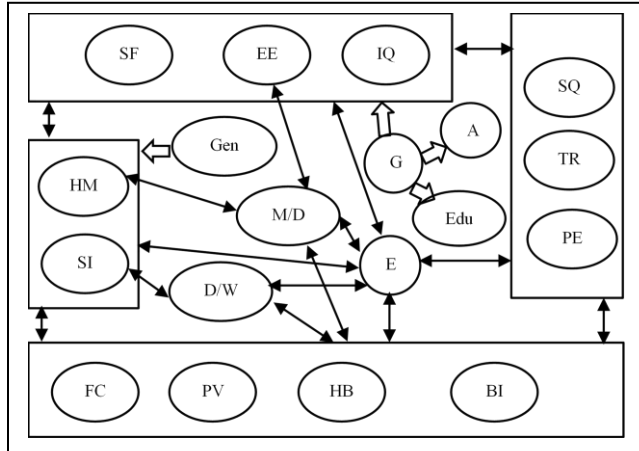

Gambar 2. Model Korelasi Antar Variabel dalam model

#### **Hasil Analisis:**

1. Terdapat korelasi positif antara variabel: Effort Expectancy, Satisfaction, Perceived Information Quality, Perceived Service Quality, Trust, Performance Expectancy, Hedonic Motivation, Social Influence, Facilitating Conditions, Habit, Price Value, dan Behavioral Intention.
2. Individu yang lebih berpengalaman akan merasa lebih: mudah, terpuaskan, percaya mendapatkan informasi dengan kualitas layanan tertentu, percayaan, terbantu dalam memperoleh keuntungan pribadi, terhibur, dipengaruhi oleh teman dan keluarga, percaya bahwa infrastruktur teknis yang mereka miliki dapat mendukung mereka, terbiasa, dapat menerima harga, dan merasa berniat dalam menggunakan teknologi e-commerce. Individu yang lebih berpengalaman juga lebih banyak menghabiskan waktu dalam menggunakan teknologi e-commerce.
3. Individu dengan tingkat pengaruh sosial dari lingkungan yang tinggi dalam menggunakan e-commerce menghabiskan waktu lebih banyak dalam menggunakan teknologi e-commerce.
4. Variabel Effort Expectancy, Satisfaction, Perceived Information Quality dan Age memiliki perbedaan yang signifikan dalam hal gender. Ini berarti bahwa pria dan wanita memiliki perbedaan persepsi dalam hal: kemudahan dalam menggunakan e-commerce, merasa puas, persepsi dalam menemukan informasi tertentu, dan usia dalam menggunakan teknologi e-commerce.

5. Perbedaan yang signifikan dalam konteks gender ditemukan dalam Sastifaction, Effort Expectancy, Information Quality, Age, dan Education. Ini berarti bahwa pria banyak yang lebih tua dan memiliki pendidikan yang lebih tinggi dibanding wanita dalam penelitian ini. Selain itu, pria kurang merasa puas dan menemukan lebih banyak kesulitan dalam menggunakan teknologi e-commerce dan kurang bisa mendapatkan informasi dengan kualitas yang lebih baik dibanding wanita.
6. Perbedaan signifikan pada generasi Z dan Y di mana ditemukan pada Hedonic Motivation dan Social Influence dan bukan pada yang lain. Ini berarti bahwa generasi Z kurang memiliki motivasi hedonis dan kurang dipengaruhi oleh teman dan keluarga dalam menggunakan e-commerce daripada generasi Y.

### B. Hasil Analisis Hipotesa:

Hasil analisa hipotesa menyatakan bahwa H1, H2, H3, H4, H5, H6, H7, H8, H9, dan H10 adalah “partially support“ dan H11 “fully support.”

### C. Perbedan Adopsi Teknologi E-Commerce Technology antara generasi Z and Y

Tabel 1. Hasil analisis perbedaan adopsi antara generasi Z dan Y

Effect	Z generation (N = 248)				Y generation (N =95)			
	Unstandardized Estimate	Statistical Significance	Standardized Estimate	Magnitude	Unstandardized Estimate	Statistical Significance	Standardized Estimate	Magnitude
IQ→ BI	-.084	NS	-.071	S	-.023	NS	-.017	S
SQ→ BI	-.112	NS	-.107	M	-.082	NS	-.060	S
TR→ BI	.042	NS	.034	S	.162	NS	.092	S
SF→ BI	-.021	NS	-.016	S	-.043	NS	-.033	S
HM→ BI	-.042	NS	-.040	S	.449	NS	.264	M
HB→ BI	.611	***	.647	L	.703	***	.627	L
PE→ BI	.254	NS	.217	M	.106	NS	.097	S
EE→ BI	.005	NS	.004	S	-.074	NS	-.063	S
PV→ BI	.216	NS	.189	M	-.147	NS	-.103	M
SI→ BI	-.046	NS	-.045	S	.045	NS	.034	S
FC→ BI	.164	NS	.136	M	.164	NS	.126	M

Note: \*\*\* indicate statistical significance at a level of 0.001 and NS indicates not statistically significant at a level of 0.05 or less.

## II. Model Adopsi Teknologi Aplikasi Media Online Entertain generasi Y dan Z

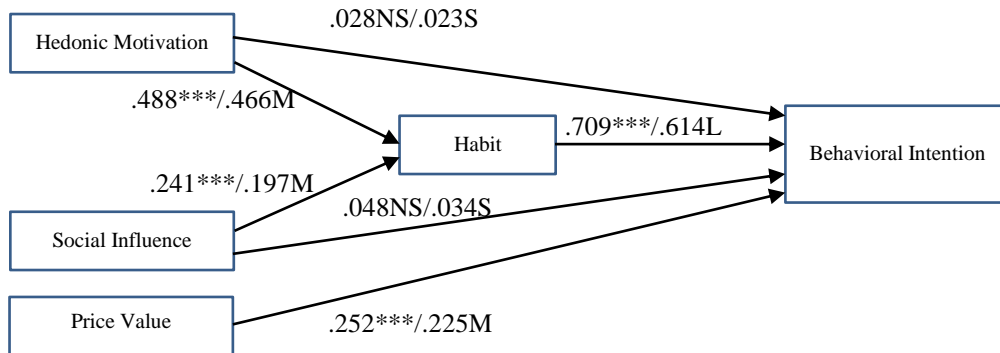

a) \*\*\* means  $p < 0.001$  and NS means not statistically significant at 0.05 level or less

b) S (Small), M (Medium), L (Large) standardized effects are those with magnitudes less than 0.1, 0.1 to less than 0.5, and equal to and more than 0.5, respectively.

Gambar 3. Model adopsi teknologi media online entertain

H1: Hedonic Motivation diprediksi memiliki pengaruh langsung yang signifikan secara statistik terhadap Behavioral Intention dalam penggunaan teknologi media online entertain.
H2: Hedonic Motivation diprediksi memiliki pengaruh langsung yang signifikan secara statistik terhadap Habit dalam penggunaan teknologi media online entertain.
H3: Habit diprediksi memiliki pengaruh langsung yang signifikan secara statistik terhadap Behavioral Intention dalam penggunaan teknologi media online entertain
H4: Social Influence diprediksi memiliki pengaruh langsung yang signifikan secara statistik terhadap Behavioral Intention dalam penggunaan teknologi media online entertain
H5: Social Influence diprediksi memiliki pengaruh langsung yang signifikan secara statistik terhadap Habit dalam penggunaan teknologi media online entertain.
H6: Price Value diprediksi memiliki pengaruh langsung yang signifikan secara statistik terhadap Behavioral Intention dalam penggunaan teknologi media online entertain.

### Hasil Analisa Hipotesa:

Tabel 2. Hasil analisa model Adopsi tecknologi media online entertain

Research Hypotheses	Reference
<b>Supported</b>	
H2: Hedonic Motivation memiliki pengaruh langsung yang signifikan secara statistik terhadap Habit.	Khatimah (2019)[14]
H3: Habit memiliki pengaruh langsung yang signifikan secara statistik terhadap Behavioral Intention.	Khatimah (2019)[14], Chopdar (2018)[15], and Venkatesh (2012)[3]
H5: Social Influence memiliki pengaruh langsung yang signifikan secara statistik terhadap Habit.	Khatimah (2019)[14]
H6: Price Value memiliki pengaruh langsung yang signifikan secara statistik terhadap Behavioral Intention.	Chopdar (2018)[15], Alalwan (2018)[16], Alalwan (2017)[?], and Venkatesh (2012)[3]

<b>Partially Supported</b>	
H1: Hedonic Motivation memiliki pengaruh langsung yang signifikan secara statistik terhadap on Behavioral Intention.	Harnadi (2017)[4], Koo (2009)[20], and Lee (2009)[10]
H4: Social Influence memiliki pengaruh langsung yang signifikan secara statistik terhadap Behavioral Intention.	Wang & Sun (2016)[7], Fan et al. (2012)[9], Venkatesh (2012)[3], Koo (2009)[20], and Lee (2009)[10]

### **Hasil Analisa Moderating Effect Generasi Z dan Y:**

Moderating effect generasi Z (925) and Y (196);

Tabel 3. Hasil analisa Moderating Effect Generasi Z dan Y

<b>Research Hypotheses</b>	<b>Comment</b>	
	<b>Effect for Z Generation</b>	<b>Effect for Y Generation</b>
Age as moderating effect		
Age sebagai "moderating effect"	Medium, Positive, Statistically significant	Medium, Positive, Statistically significant
Age tidak memiliki "moderating effect" yang signifikan pada pengaruh langsung Hedonic Motivation ke Habit	Medium, Positive, Statistically significant	Medium, Positive, Not Statistically significant
Age tidak memiliki "moderating effect" yang signifikan pada pengaruh langsung Social Influence ke Habit	Large, Positive, Statistically significant	Large, Positive, Statistically significant
Age memiliki "moderating effect" yang signifikan pada pengaruh langsung Habit ke Behavioral Intention	Small, Positive, Not Statistically significant	Small, Positive, Not Statistically significant
Age tidak memiliki "moderating effect" yang signifikan pada pengaruh langsung Hedonic Motivation ke Behavioral Intention	Medium, Positive, Statistically significant	Medium, Positive, Not Statistically significant
Age tidak memiliki "moderating effect" yang signifikan pada pengaruh langsung Price Value ke Behavioral Intention	Small, Positive, Not Statistically significant	Medium, Positive, Not Statistically significant

Dari hasil analisis dapat ditarik kesimpulan, bahwa:

1. Variabel Hedonic Motivation dan Social Influence memiliki pengaruh yang signifikan terhadap Kebiasaan dalam menggunakan media online entertain yang pada akhirnya menentukan tingkat adopsi teknologi tersebut.
2. Variabel berikutnya yang mempengaruhi tingkat adopsi media online entertain adalah Price Value.
3. Dari analisis, perbedaan antara kedua generasi Z dan Y dalam mengadopsi media online entertain lebih ditentukan oleh kebiasaan mereka dalam menggunakan media online entertain.

### III. Model adopsi teknologi smartphone untuk pembelajaran

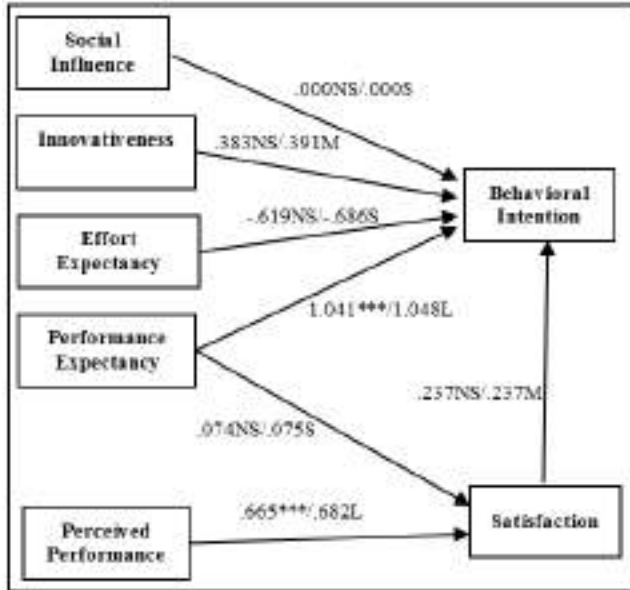

Gambar 4. Model adopsi teknologi smartphone untuk pembelajaran

H1: Social Influence diprediksi memiliki pengaruh langsung yang signifikan secara statistik terhadap Behavioral Intention dalam penggunaan teknologi smartphone untuk pembelajaran
H2: Innovativeness diprediksi memiliki pengaruh langsung yang signifikan secara statistik terhadap Behavioral Intention dalam penggunaan teknologi smartphone untuk pembelajaran
H3: Effort Expectancy diprediksi memiliki pengaruh langsung yang signifikan secara statistik terhadap Behavioral Intention dalam penggunaan teknologi smartphone untuk pembelajaran
H4a: Performance Expectancy diprediksi memiliki pengaruh langsung yang signifikan secara statistik terhadap Behavioral Intention dalam penggunaan teknologi smartphone untuk pembelajaran.
H4b: Performance Expectancy diprediksi memiliki pengaruh langsung yang signifikan secara statistik terhadap Satisfaction dalam penggunaan teknologi smartphone untuk pembelajaran
H5: Perceived Performance diprediksi memiliki pengaruh langsung yang signifikan secara statistik terhadap Satisfaction dalam penggunaan teknologi smartphone untuk pembelajaran.
H6: Satisfaction diprediksi memiliki pengaruh langsung yang signifikan secara statistik terhadap Behavioral Intention dalam penggunaan teknologi smartphone untuk pembelajaran.

Berdasarkan analisa korelasi dan analisa *causal effect* terbukti bahwa H1, H2, H3, H4a, dan H6 adalah “partially support” dan hanya dua hipotesa H4b dan H5 adalah “fully support”.

1. Dari analisis, dapat ditarik kesimpulan bahwa responden dalam penelitian ini yaitu mahasiswa perguruan tinggi akan lebih dapat mengadopsi smartphone untuk pembelajaran bila mereka merasakan manfaat langsung dari penggunaan smartphone untuk pembelajaran.
2. Mahasiswa akan merasa puas dalam menggunakan smartphone untuk pembelajaran bila mereka telah membuktikan bahwa smartphone yang mereka pergunakan benar-benar dapat membantu mereka belajar.

Dokumen pengujian Model:

## **MODEL DAN IMPLEMENTASI INDUSTRI KREATIF DIGITAL BERBASIS ADOPSI TEKNOLOGI INFORMASI GENERASI Y DAN Z**

- I. Model adopsi teknologi E-Commerce pada generasi Y dan Z**
- II. Model adopsi teknologi Media Online Entertain pada generasi Y dan Z**
- III. Model adopsi teknologi smartphone untuk pembelajaran**







Dokumen pendukung luaran Tambahan #1

Luaran dijanjikan: Prosiding dalam pertemuan ilmiah Nasional

Target: sudah terbit/sudah dilaksanakan

Dicapai: Accepted

Dokumen wajib diunggah:

1.

Dokumen sudah diunggah:

1. Surat keterangan accepted dari editor

Dokumen belum diunggah:

-

# Investigation of Adoption of Smartphone Technology for Learning

FX Hendra Prasetya  
Department of Information System  
Soegijapranata Catholic University  
Semarang, Indonesia  
hendra@unika.ac.id

Bernardinus Harnadi  
Department of Information System  
Soegijapranata Catholic University  
Semarang, Indonesia  
bharnadi@unika.ac.id

**Abstract**—In this study, we will investigate the adoption of smartphones for learning. The 160 respondents are fulfill the questionnaires to test the proposed model. UTAUT and ECM (Expectation-Confirmation Model) models was employed to predict the Behavioral Intention. The findings reveal that Social Influence, Innovativeness, Effort Expectancy, Performance Expectancy, Perceived Performance, Satisfaction, and Behavioral Intention have significantly relation to each other. Surprisingly, the Performance Expectancy is the main variable on the adoption of smartphone technology for learning and Perceived Performance is variable determining the user can satisfy in using smartphone technology for learning. Behavioral variables naming Age and Experience have important role in the relationship of variables in the study. The older and experienced users of smartphone for learning have highly concern with performance of smartphone and more satisfy with their learning application on smartphone.

**Keywords**— *Adoption, Technology, Smartphone, Learning*

## I. INTRODUCTION

The smartphone users in Indonesia increased every years. On 2016 the smartphone users was 65.2 million, they increase to 74.9 million on 2017 and 83.5 million on 2018 and they was predicted up to 92 million [1]. Similarly, the adoption of smartphone for learning in Indonesia was increased. According to [2] Indonesian students who use smartphones to do their homework are 81%, they who use smartphones during their lessons are 67%, and they who study Computer Science are 39%. Some special applications used by students for learning in Indonesia are "Ruang Guru" and "Ruang Belajar".

The studies of technology adoption in general has been widely investigated by Harnadi [3], Chen [4], Hamidi and Chavoshi [5], Alalwan et al [6], and Venkatesh et al [7]. The specific study on technology adoption also investigated on smartphone usage for learning [4], [3], [8], [9], and [10]. The related study on e-learning has also been investigated by Tarhini et al [11], Chow and Shi [12], Al-Adwan et al [13], and Prieto et al [14]. This study is based on the UTAUT conducted by Venkatesh et al [7] and ECM model conducted by Ghan and Akkoyunlu [10] and Chow and Shi [12].

The UTAUT model employed variables naming Social Influence, Performance Expectancy, Export Expectancy, Facilitating Conditions, Hedonic motivation, Price Value and Habit, whereas in the ECM Model employed Satisfaction as confirmation variable prior to the Behavioral Intention. All variables such as Perceived Value, Expectations Outcome, Confirmation, Utilitarian Value, Information Quality, System Quality and Service Quality have direct effect on Satisfaction.

This Study have purposed to investigate adoption of smartphone technology for learning employing UTAUT and ECM model. The study examines the behavioral variables such as experience and age regard to theirs relationship to others variables in the proposed model. The relationship will test using Pearson Correlation to establish the statistically significant correlation among variable.

## II. PROPOSED MODEL AND HYPOTHESIS

Reviewing several related literature on adoption of e-learning, mobile learning, and adoption technology in general for six years are discussed to obtain the proposed model.

### A. *Social Influence and Innovativeness on Behavioural Intension*

Social Influence is "the extent to which consumers perceive that important others (e.g., family and friends) believe they should use a particular technology" [11]. Innovativeness means "the willingness of an individual to accept innovation earlier than others in terms of a certain product, technology, lifestyle, or consumption pattern" [8].

The study conducted by Akbar [16], Venkatesh et al [7] reveal that Social Influence was strong variable to predict Behavioral Intention to use technology. Social Influence also verified as strong predictor to e-learning adoption [11].

Research conducted by Kim et al [8] and Alalwan et al [6] shows that Innovativeness variables correlate with Behavioral Intention to use technology and e-learning. So as, we proposed: *Social Influence will have a significant correlation on Behavioral Intention (H1) and Innovativeness will have a significant correlation on Behavioral Intention (H2).*

### B. *Performance Expectancy and Effort Expectancy on Behavioural Intention*

Performance Expectancy is defined as "the degree to which using a technology will provide benefits to consumers in performing certain activities" [11]. Effort Expectancy "is the degree of ease associated with consumers' use of technology" [11]. Behavioral Intention the extent to which the user intends to use smartphone for learning in the future

The study conducted by Alalwan et al [6], Joo and Sang [9], Ing and Degoulet [15], Akbar [16], and Venkatesh et al [7] reveal that Performance Expectancy was strong variable to predict Behavioral Intention to use technology. Variable Performance Expectancy also verified as strong predictor to e-learning adoption [5], [11], [13].

Research conducted by Hamidi and Chavoshi [5], Alalwan et al [6], Venkatesh et al [7], Joo and Sang [9], Tarhini et al [11], and Akbar [16] shows that Effort

Expectancy variables correlate with Behavioral Intention to use technology and e-learning. So as, we proposed: *Effort Expectancy will have a significant correlation on Behavioral Intention (H3) and Performance Expectancy will have a significant correlation on Behavioral Intention (H4a).*

### C. Performance Expectancy and Perceived Performance on Satisfaction

Perceived Performance is “a key performance index in mobile communication and an important antecedent to satisfaction”[10].

Satisfaction is “the affective attitude towards a particular computer application by an end user who interacts with the application directly” [17].

Research conducted by Guao et al [18], Oghuma et al [17], Ghan and Akkoyunlu [10] shows a strong relationship between variable Performance Expectancy and Satisfaction in the use of technology and also in e-learning. While the research conducted by Oghuma et al [17] and Ghan and Akkoyunlu [10] also shows a strong relationship between Perceived Performance variables, especially the Perceived Service Quality with Satisfaction variables. So as, we proposed: *Performance Expectancy will have a significant correlation on Satisfaction (H4b) and Perceived Performance will have a significant correlation on Satisfaction (H5).*

### D. Satisfaction on Behavioural Intension

The study conducted by Ing and Degoulet [15], Guoa et al [19], Oghuma et al [17] reveal that Performance Expectancy was strong variable to predict Behavioral Intention to use technology. Variable Performance Expectancy also verified as strong predictor to e-learning adoption [18], [12], [10]. So as, we proposed: *Satisfaction will have a significant correlation on Behavioral Intention (H6).*

The Proposed model employed Social Influence, Effort Expectancy, Innovativeness, and Performance Expectancy to have direct effect on Behavioral Intention and employed Perceived Performance and Performance Expectancy to have direct effect on Satisfaction and Satisfaction have direct effect on Behavioral Intention. The proposed model can be look at Fig.1.

## III. METHODOLOGY

This study used data from 160 respondents from students on Senior High School and College/University in Semarang, Indonesia. This data was examined using statistical techniques using SPSS software after passing the data preparation stage.

The variables employing in the model was tested using validity and reliability tests. The correlations analysis of the variables naming Social Influence, Innovativeness, Effort Expectancy, Performance Expectancy, Perceived Performance, Satisfaction, and Behavioral Intension are done by the Pearson correlation analysis. The last causal effect analysis using AMOS-SPSS was done to get the finding on the adoption of smartphone technology for learning.

## IV. DATA ANALYSIS

### A. Demographic of Respondents

The data used in this study were 160 students consisting of 115 male and 45 female. The 160 students were

categorized into 70 students of Z generation (15-19 years old) and 90 student of Y generation (20-25 years).

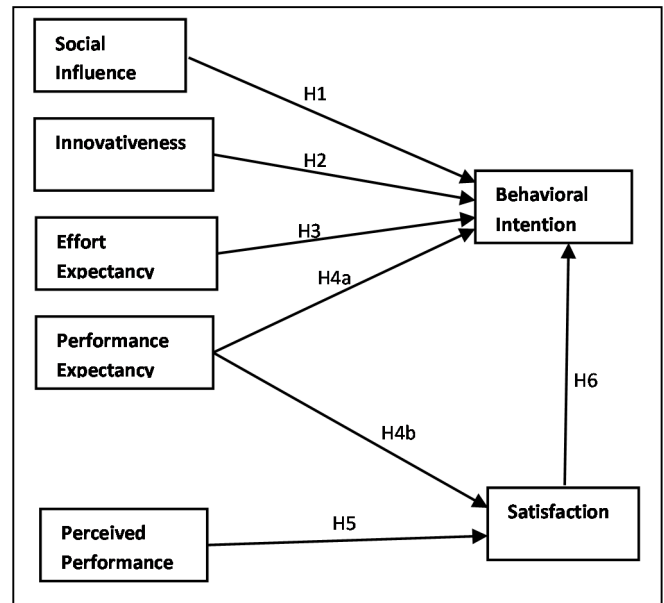

Fig. 1. Model of Research

The distribution of the experience in using smartphone for learning is described follows: 12 students have experience less than or equal to 1 year, 17 students have experience more than 1 year and less than or equal to 2 years, 21 students have experience more than 2 year and less than or equal to 3 years, and 110 students have experience more than or equal to 4 years.

### B. Validity Test of Variables

The results of the validity test of variables was shown on Table I. The table shows that all indicators grouped in certain it's variable column is convergent and valid.

TABLE I. VALIDITY TEST OF VARIABLES

	Component				
	PP-SI	I	SI	EE-PE	In
SI1	-.012	.261	.772	.049	.152
SI2	.146	.145	.823	.125	.056
SI3	.046	.196	.480	.297	.055
In1	.073	.075	.096	-.003	.799
In3	-.061	.036	.007	.110	.821
EE1	.183	.057	-.007	.793	.233
EE2	.298	-.002	.127	.602	.483
EE3	.356	.128	.266	.507	.437
PE1	.099	.397	.312	.637	-.123
PE2	.095	.521	.294	.431	.030
PE3	.258	.354	.344	.502	-.018
PP3	.454	.112	.441	.132	.279
PP4	.587	.133	.405	.138	.109
PP5	.612	.101	.410	.286	.062
S1	.799	.064	.042	.166	.137
S2	.712	.237	.013	.209	.137
S3	.706	.323	.021	.204	-.106
I1	.237	.774	.166	-.016	.213
I2	.105	.826	.195	.148	.134
I3	.149	.819	.175	.214	-.042

### C. Reliability Test of Variables

Variable reliability test using Cronbach alpha analysis, the result can be look at Table II.

TABLE II. RESULT TEST RELIABILITY

Variable	Cronbach's Alpha	Comment
SI	.709	Acceptable
In	.652	Questionable
EE	.791	Acceptable
PE	.770	Acceptable
PP	.772	Acceptable
S	.795	Acceptable
I	.843	Good

The results of the test reliability variable indicate that the variable Social Influence, Effort Expectancy, Performance Expectancy, Perceived Performance, and Satisfaction are "Acceptable" meaning that the reliability is acceptable. For the Behavioral Intention reliability variable "Good" means Good, while the Innovativeness variable is "Questionable" which means it is feasible in the questionnaire.

D. Correlation Analysis of Variables

Correlation Analysis using Pearson correlation can be look at Table III.

TABLE III. RESULT TEST CORRELATION VARIABLE

	Age	Edu	Exp	RSI	RIn	REE	RPE	RPP	RS	RI
Age	1	.172*	.069	-.073	.172*	-.018	-.096	.156*	.175*	.001
Edu	.172*	1	.187*	.062	-.037	-.004	-.079	.040	.029	.029
Exp	.069	.187*	1	.182*	-.009	.177*	.229**	.160*	.226**	.133
RSI	-.073	.062	.182*	1	.198*	.382**	.524**	.479**	.299**	.464**
RIn	.172*	-.037	-.009	.198*	1	.415**	.111	.217**	.130	.157*
REE	-.018	-.004	.177*	.382**	.415**	1	.544**	.551**	.503**	.346**
RPE	-.096	-.079	.229**	.524**	.111	.544**	1	.531**	.437**	.607**
RPP	.156*	.040	.160*	.479**	.217**	.551**	.531**	1	.564**	.437**
RS	.175*	.029	.226**	.299**	.130	.503**	.437**	.564**	1	.409**
RI	.001	.029	.133	.464**	.157*	.346**	.607**	.437**	.409**	1

The test results show that all variables are Social Influence, Innovativeness, Effort Expectancy, Performance Expectancy, Perceived Performance, and Satisfaction correlate with Behavioral Intention variables according to hypothesis 1 to 6.

E. Causal Effect Analysis

The causal effect analysis of model was done by AMOS-SPSS and the result was shown on Figure 2. According to the Figure, the statistically significant direct effects were only on the relation of Performance Expectancy on Behavioral Intention and Perceived Performance on Satisfaction. The other relations were not statistically significant.

V. FINDING AND DISCUSSION

From correlation analysis, the variables Social Influence, Innovativeness, Effort Expectancy, Performance Expectancy, Perceived Performance, and Satisfaction have significantly correlation to Behavioral Intention. It is surprisingly that the variables Innovativeness, and Perceived Performance, and Satisfaction coming from ECM model are significant.

The user experience in using smartphone for learning is the important behavioral variable in the relation to other variables except to Age, Innovativeness and Behavioral Intention. It means that users of smartphone for learning with high experience are more influence with their friends and

family, perceive more ease in using smartphone, more helped in take personal gain, have high concern with performance of smartphone, and more satisfy with their learning application on smartphone.

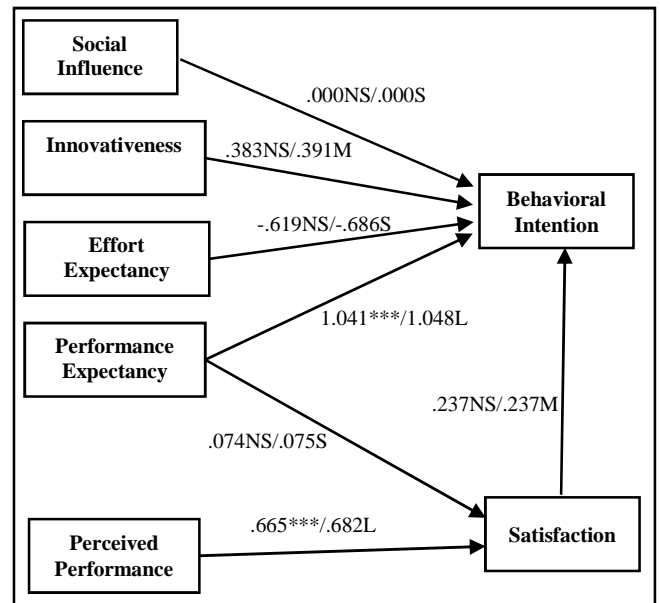

Fig. 2. The Result of Causal Effect Analysis of the model

All of variables (Social Influence, Innovativeness, Effort Expectancy, Performance Expectancy, Perceived Performance, Satisfaction, and Behavioral Intention) are significant correlate to each other. The age ranges of users are on 14 – 25 years old. The Age variable is significant correlation to Innovativeness, Perceived Performance, and Satisfaction. It means that the older users of smartphone for learning are more innovative, have highly concern with performance of smartphone, and more satisfy with their learning application on smartphone.

This study reveals that two behavioral variable naming Age and Experience have significantly correlation with perceive performance and Satisfaction. It means that older and experienced users of smartphone for learning have highly concern with performance of smartphone and more satisfy with their learning application on smartphone.

Based on correlation and causal effect analysis, the hypotheses H1, H2, H3, H4a, and H6 are partially support. Only two hypotheses H4b and H5 are fully support. It means that Performance Expectancy is main variable deciding the adoption of smartphone technology for learning and Perceived Performance is variable determining the users satisfy to smartphone technology.

The findings shows that the variables employed in this study and behavioral variable including Age and Experience have an importance role in supporting the adoption of smartphone for learning.

ACKNOWLEDGMENT

The research is funded by the Ministry of Research, Technology and Higher Education of the Republic of Indonesia including the support from Department of Information Systems, Soegijapranata Catholic University, Indonesia.

## REFERENCES

- [1] Admin. (2016, Augt.) Pengguna Smartphone di Indonesia 2016-2019. [Online]. Available <https://databoks.katadata.co.id/datapublish/2016/08/08/pengguna-smartphone-di-indonesia-2016-2019>.
- [2] Admin, (2018, May) Global Education Census. [Online]. Available <https://www.cambridgeinternational.org/about-us/edcensus>.
- [3] B. Harnadi, "An investigation of the adoption of online game technologies in Indonesia," *International Journal of Gaming and Computer-Mediated Simulations*, vol.9, issue 1, pp. 1–27, 2017.
- [4] Chih-Ping Chen, "Understanding mobile English-learning gaming adopters in the self-learning market: The Uses and Gratification Expectancy Model", *Computers & Education*, vol. 126, pp. 217-230, <https://doi.org/10.1016/j.compedu.2018.07.015>, 2018.
- [5] H. Hamidi, A. Chavoshi, "Analysis of the essential factors for the adoption of mobile learning in higher education: A case study of students of the University of Technology", *Telematics and Informatics*, vol. 35, pp. 1053-1070, <http://dx.doi.org/10.1016/j.tele.2017.09.016>, 2017.
- [6] Ali Abdallah Alalwan, Abdullah Baabdullah, Nripendra P. Rana, Kuttimani Tamilmani, Yogesh K. Dwivedi, "Examining adoption of mobile internet in Saudi Arabia: Extending TAM with perceived enjoyment, innovativeness and trust", *Technology in Society*, doi: 10.1016/j.techsoc.2018.06.007, 2018.
- [7] V. Venkatesh, J. Y. L. Thong, & X. Xu, "Extending the Unified Theory of Acceptance and Use of Technology", *MIS Quarterly*, vol. 36, no. 1, pp. 157–178, 2012.
- [8] Hyo-Jung Kim, Jin-Myong Lee, Jong-Youn Rha, "Understanding the role of user resistance on mobile learning usage among university students", *Computers & Education*, vol. 113, pp. 108-118, <http://dx.doi.org/10.1016/j.compedu.2017.05.015>, 2017.
- [9] Joo & Sang, "Exploring Koreans' smartphone usage: An integrated model of the technology acceptance model and uses and gratifications theory", *Computers in Human Behavior*, vol. 29, pp. 2512-2518, <http://dx.doi.org/10.1016/j.chb.2013.06.002>, 2013
- [10] Gokhan Da ghan, Buket Akkoyunlu, "Modeling the continuance usage intention of online learning environments", *Computers in Human Behavior*, vol. 60, pp. 198-211, <http://dx.doi.org/10.1016/j.chb.2016.02.066>, 2017.
- [11] Ali Tarhini, Kate Hone, Xiaohui Liu & Takwa Tarhini, "Examining the moderating effect of individual level cultural values on users' acceptance of Elearning in developing countries: a structural equation modeling of an extended technology acceptance model", *Interactive Learning Environments*, <http://dx.doi.org/10.1080/10494820.2015.1122635>, 2016
- [12] Wing S. Chow, Si Shi, "Investigating Students' Satisfaction And Continuance Intention Toward E-Learning: An Extension Of The Expectation–Confirmation Model", *Procedia - Social and Behavioral Sciences*, vol. 141, pp. 1145-1149, <http://creativecommons.org/licenses/by-nc-nd/3.0/>, 2014.
- [13] Amer Al- Adwan, Ahmad Al- Adwan, Jo Smedley, "Exploring students acceptance of e-learning using Technology Acceptance Model in Jordanian universities," *International Journal of Education and Development using Information and Communication Technology (IJEDICT)*, Vol. 9, Issue 2, pp. 4-18, 2013.
- [14] José Carlos Sánchez Prieto, Susana Olmos Migueláñez, Francisco J. García-Peñalvo, "ICTs Integration in Education: Mobile Learning and the Technology Acceptance Model (TAM)", *Second International Conference on Technological Ecosystems for Enhancing Multiculturality*, pp. 683-687, 2014.
- [15] Brahim Hadji Ing, Patrice Degoulet, "Information System End-user Satisfaction and Continuance Intention: a Unified Modeling Approach", *Journal of Biomedical Informatics*, doi: <http://dx.doi.org/10.1016/j.jbi.2016.03.021>, 2016.
- [16] Akbar, F., "Investigating students' acceptance an use of technology in academic environment", : <http://repository.cmu.edu/hsshonors>, 2013
- [17] Apollos Patricks Oghuma, Christian Fernando Libaque-Saenz, Siew Fan Wong, Younghoon Chang, "An expectation-confirmation model of continuance intention to use mobile instant messaging ", *Telematics and Informatics*, vol. 33, pp. 34-47, 2016.
- [18] Zixiu Guoa, Lin Xiaob, Christine Van Toorna, Yihong Laia, Chanyoung Seoa, "Promoting Online Learners' Continuance Intention: An Integrated Flow Framework", , *Information and Management*, <http://dx.doi.org/10.1016/j.im.2015.10.010>, 2016.
- [19] Chin-Lung Hsu, Judy Chuan-Chuan Lin, "What drives purchase intention for paid mobile apps? – An expectation confirmation model with perceived value", *Electronic Commerce Research and Applications*, vol. 14, pp. 46-57, <http://dx.doi.org/10.1016/j.elerap.2014.11.003>, 2015.

# [ICSEC 2019] Your paper #1570584041 ('Investigation of Adoption of Smartphone Technology for Learning')



**icsec2019@phuket.psu.ac.th** via edas.info  
to FX, me

Aug 23, 2019, 5:36 PM



Dear Mr. FX Prasetya:

Congratulations - your paper #1570584041 ('Investigation of Adoption of Smartphone Technology for Learning') has been accepted for presentation in ICSEC 2019, and will be published in the Proceedings of ICSEC 2019. All presented papers will be submitted to IEEE Xplore.

Please reflect the reviewers' comments into your final manuscript, the detail reviews are below or can be found at <https://edas.info/showPaper.php?m=1570584041>, using your EDAS login name [hendra@unika.ac.id](mailto:hendra@unika.ac.id).

Please also consider 4 mandatory steps for authors in submitting the camera-ready manuscript:

1. Registration and Payment Please be reminded that the due date for early bird registration is 16 October 2019. At least one author has to register for the conference. Payment and registration details can be found at <https://www.icsec2019.org/registration.php>.
2. Final Manuscript Preparation Papers must be written on A4-format page according to the IEEE template Manuscripts of minimum four (4) pages and up to six (6) pages in length. Submissions exceeding 6 pages will be charged extra page length, 50 US Dollars for each one additional page. Maximum accepted pages are ten (10) pages. Papers should NOT have page numbers, headers, and footers.
3. IEEE PDF eXpress (IEEE Xplore compatible) Your revised manuscript must be compatible with IEEE Xplore. Please check with PDF eXpress [www.pdf-express.org](http://www.pdf-express.org) using the Conference ID: 47112XP.
4. Camera-Ready Paper Upload and Copyright Transfer After passing the IEEE Xplore compatible, the camera-ready manuscript should be submitted in the same manner as the review manuscript using EDAS at <https://edas.info/showPaper.php?m=1570584041> before 16 September 2019. Electronic copyright form should also be submitted electronically through EDAS.

Should you have any question, please do not hesitate to contact us. We look forward to seeing you at the Conference.

We look forward to seeing you at the conference.

Best Regards,

ICSEC 2019 Program Committee Chairs

Dokumen pendukung luaran Tambahan #2

Luaran dijanjikan: Prosiding dalam pertemuan ilmiah Internasional

Target: sudah terbit/sudah dilaksanakan

Dicapai: Accepted

Dokumen wajib diunggah:

1.

Dokumen sudah diunggah:

1. Naskah artikel

Dokumen belum diunggah:

-

# The Difference Adoption of E-Commerce Technology among Z and Y Generations

Bernardinus Harnadi  
Department of Information Systems  
Soegijapranata Catholic University  
Semarang, Indonesia  
bharnadi@unika.ac.id

Albertus Dwiyoga  
Department of Information Systems  
Soegijapranata Catholic University  
Semarang, Indonesia  
yoga@unika.ac.id

FX. Hendra Prasetya  
Department of Information Systems  
Soegijapranata Catholic University  
Semarang, Indonesia  
hendra@unika.ac.id

**Abstract**— The rapid growth of e-commerce transactions among Y and Z generations in Indonesia goes along with the large number of internet users on both of the generations. Indonesia has become a potential market for the digital creative industry, especially to applications of online payments, online shopping, online booking, and online banking. In-depth investigations into these two generations in the form of developing e-commerce technology adoption models will provide valuable contributions in the development of models and implementation of e-commerce industries in Indonesia. This study aims to obtain factors that influence the acceptance of generation Z and Y against e-commerce technology and reveal the differences in their acceptance of it. Investigation was done by collecting 343 questionnaires in age range of Y and Z generations. The results of this study reveal that all variables employing in the model naming Satisfaction, Trust, Perceived Information Quality, Perceived Service Quality, Performance Expectancy, Effort Expectancy, Hedonic Motivation, Social Influence, Price Value, Habit, and Facilitating Conditions have statistically significantly correlation to Behavioral Intention and to each other. The significantly difference of adoption of e-commerce technology among Z and Y generations are only found on Hedonic Motivation and Social Influence. The other difference on gender is found on Age, Education, Satisfaction, Effort Expectancy, and Perceive Information Quality. This study can contribute to who have concern on enhance adopting of e-commerce technology especially to the two generations, especially developers of e-commerce application considering the factors that have correlation to intention to use e-commerce.

**Keywords**—adoption technology, e-commerce, Z generation, Y generation

## I. INTRODUCTION

According to Special Reports, Digital 2019 [1], the total population of the world is 7.676 billion with 5.112 billion of its are unique mobile users and 4.388 billion of its are internet users. E-commerce Infographic 2019 by Einstein Marketer report [2] stated that the mobile internet as share of total e-commerce transactions are 67.2% in 2019 and estimated up to 70.4% & in 2020. In Indonesia context, the survey conducted by APJII in 2018[3] stated that 64.8% of Indonesia population (264. 16 million) or 171. 17 million is internet users. Regard to the survey, 91 % of Z generation in the age range of 15 – 19 years old are internet users, whereas Y generation in the age range of 20 – 24 years old are 85.5% .

The penetration of online shopping in Indonesia is 36.6% of internet users [3] that separated on four online shopping applications including Shopee, Bukalapak, Lazada, and Tokopedia.

The purpose of this research is to investigate the difference among Z and Y generation in accepting e-commerce technology through studying factors related to intention to use

e-commerce technology. The study address research questions: what are the factors that are related to adopting e-commerce technology among Z and Y generations and; what are the relationships among these factors?

The outcomes of the study are expected to contribute to a theoretical understanding of the adopting e-commerce technology and to provide advice for practitioners who have interests in increasing of e-commerce adoption among the two generations. Furthermore the study also has contribution to the practice. The practitioners will gain more understanding about human factors, such as personality traits, that affect a user's intentions of e-commerce. Other factors reflecting the different adoption between Z and Y generations and male and female may enable practitioners to design campaign and other efforts based on the different motivation among them.

## II. FACTORS RELATED TO ADOPTING ON E-COMMERCE IN PREVIOUS STUDIES

Reviewing literatures in previous studies are conducted on the adoption technology of e-commerce. Several models are employed on the studies including TAM, TPB, and UTAUT. The main objectives of these studies concern the exploration and understanding of human behaviors related to adopting and using e-commerce. The discussion on variables supported direct antecedent on behavioral intention to use e-commerce technology is discussed in detail. In the context of adoption of ecommerce technology Behavioral Intention can be defined as “The extent to which the user intends to use a system in the future. [4]”

### A. Perceived Information Quality and Perceived Service Quality

According to [5], Perceived Information quality is the quality of relevance, sufficiency, accuracy and timeliness of information got by users. meanwhile Baabullah (2019) defined Perceived Service Quality as “the overall support delivered by the service provider” to ascertain empathy, assurance, and responsiveness delivered to users.

References [5] and [6] conducted studies on M-banking acceptance and employed Perceived Information Quality and Perceived Service Quality as variables having direct effect to m-banking acceptance. Meanwhile reference [7] also conduct study on m-banking acceptance and reveal that Perceived Information Quality has a direct effect on m-banking acceptance. For these reasons, Perceived Information Quality and Perceived Service Quality are predicted to have positive direct effect on Behavioral Intention to use e-commerce technology (H1 and H2).



## B. Trust and Satisfaction

Trust and Satisfaction were importance variables on e-commerce studies. Trust was defined by Verkijika [8] as “the extent to which an individual believes that using m-commerce is secure and has no privacy threats.” According to [5], Satisfaction is acquired by positive experience with using of a service. References [9], [8], and [10] conducted study on mobile shopping acceptance and References [5], [7], [8], [11], [12], and [13] conducted study on m-banking acceptance verified that Trust and Satisfaction were importance variables in e-commerce study. References [5] and [10] reveal that Satisfaction has direct effect on m-banking and m-shopping acceptance, respectively. Meanwhile, References [11] and [12] reveal that Trust has significantly direct effect on m-banking acceptance. Similarly Reference [9] also reveal that Trust has significantly direct effect on m-shopping acceptance. Furthermore, the study conducted by [13] reveals that Trust has direct effect on Satisfaction. On the study of adoption mobile internet, Reference [14] revealed that Trust also has direct effect on Behavioral Intention to use e-commerce technology. For these reasons, Trust and Satisfaction are predicted to have positive direct effect on Behavioral Intention to use e-commerce technology (H3 and H4).

## C. Hedonic Motivation

References [15] defined Hedonic Motivation as the fun or enjoy derived with use of a technology. Several researchers used Perceived Enjoyment ([4], [10], [14]) and Flow Experience ([4]) to refer Hedonic Motivation. According to [8], [10], [11], [14], [15], [16], [17], and [18], Hedonic Motivation has direct effect on e-commerce acceptance. For these reasons, Hedonic Motivation is predicted to have positive direct effect on Behavioral Intention to use e-commerce technology. [H5]

## D. Performance Expectancy and Effort Expectancy

Performance Expectancy is defined by Harnadi [4] as “the extent to which an individual believes that using the system will help them to attain personal gains”. Effort Expectancy is defined by Venkatesh et al[15] as “the degree of ease associated with consumers’ use of technology”. Performance Expectancy and Effort Expectancy have proven as main variables on adoption technology researches. On TAM model by Davis [19], these variables naming Perceived Usefulness and Perceived Ease of Use have significantly correlation to Behavioral Intention through variable Attitude. On the research conducted by Venkatesh et al[20], Attitude was not employed. He argues that without Attitude, the two variables Performance Expectancy and Effort Expectancy have significantly correlation to Behavioral Intention. Several researchers on e-commerce adoption ([10], [11], [15], [16], [21], [22]) stated that Performance Expectancy has direct effect on Behavioral Intention to use e-commerce technology, meanwhile References [18] and [23] reveal that Performance Expectancy has direct effect on Use Behavior of e-commerce technology. Meanwhile [12] and [24] stated that Performance Expectancy has direct effect on Behavioral Intention to use e-commerce through Attitude. On the studies of adoption of mobile internet conducted by Alalwan et al[14] and online gaming technology conducted by Harnadi [4], they revealed that Performance Expectancy has direct effect on Behavioral Intention to use e-commerce technology.

Effort Expectancy was also used as variable in model to predict Behavioral Intention to use e-commerce technology. The study conducted by Alalwan et al[11], Alalwan et al[14], Venkatesh et al[15], Chopdar et al[16], and Martins et al[21] stated that Effort Expectancy has direct effect on Behavioral Intention to use e-commerce. Reference [12] also stated that Effort Expectancy has direct effect on Behavioral Intention to use e-commerce through Attitude. For these reasons, Performance Expectancy and Effort Expectancy are predicted to have positive direct effect on Behavioral Intention to use e-commerce technology (H6 and H7).

## E. Price Value and Facilitating Conditions

Price Value was defined by Venkatesh et al[15] as “consumers’ cognitive tradeoff between the perceived benefits of the applications and the monetary cost for using them”. References [11], [14], [15], and [16] reveal that Price Value has direct effect on Behavioral Intention to use e-commerce technology. Reference [18] also revealed that Price Value has direct effect on Use Behavior in using e-commerce technology.

According to [4], Facilitating Conditions is “the extent to which an individual believe that there is organizational and technical infrastructure supporting in using a systems”. The studies conducted by Verkijika et al[8], Venkatesh et al[15], and Chopdar et al[16] stated that Facilitating Conditions has direct effect on Behavioral Intention to use e-commerce technology. References [15] and [18] revealed that Facilitating Conditions also has significant direct effect on Use Behavior in using e-commerce technology. For these reasons, Price Value and Facilitating Conditions are predicted to have positive direct effect on Behavioral Intention to use e-commerce technology (H8 and H9).

## F. Social Influence and Habit

Reference [22] defined Social Influence as “the perceived social pressure from close members to the individual to perform or not to perform the behavior in question”. The studies conduct by Venkatesh et al [15], Martins et al[21], and Alshare et al[22] reveal that Social Influence has direct effect on Behavioral Intention to use e-commerce technology.

Habit was defined by Venkatesh et al [15] as “the extent to which people tend to perform behaviors automatically because of learning and the behaviors was the results of prior experiences.” References [15] and [16] conducted study in adoption e-commerce technology and revealed that Habit has direct effect on Behavioral Intention to use e-commerce technology. In other hand, [15] and [18] revealed that Habit also has direct effect on Use Behavior in using e-commerce technology. For these reasons, Social Influence and Habit are predicted to have positive direct effect on Behavioral Intention to use e-commerce technology (H10 and H11).

## III. PROPOSED MODEL AND HYPOTHESIS

Based on the literature reviews, a theoretical model is proposed on Figure 1. In the theoretical model there are eleven independent variables relating to one dependent variable Behavioral Intention. The eleven variables (Perceived Information Quality, Perceived Service Quality, Trust, Satisfaction, Hedonic Motivation, Performance Expectancy, Effort Expectancy, Price Value, Social Influence, Habit, and Facilitating Conditions) have significant direct effect on Behavioral Intention.

#### IV. METHOD

The study is a field study which aims to develop theoretical knowledge with practical implications concerning factors that influence the use of e-commerce platform among the target population of individuals with e-commerce experience currently on Z and Y generations in Indonesia. The questionnaires were collected from students on high schools and universities. The students are in age range of 15 - 25 years.

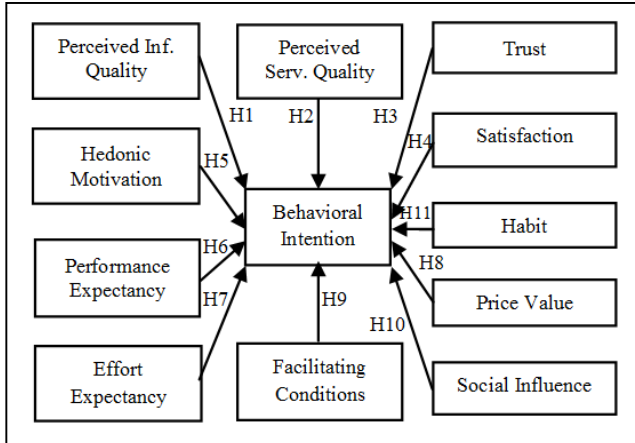

Fig. 1. Proposed Theoretical Model.

The literature review presents a comprehensive survey of previous studies related to the variables that influence the adoption and use of e-commerce by individuals. Based on this review a theoretical model is developed which incorporates the important variables and their relationships.

A self-administered questionnaire is used to measure the variables. In order to improve the validity and reliability of measures wherever possible the questionnaire adapts existing measuring instruments used in previous studies. The questionnaire was prepared in two sections. The first section presents questions related to profile of the respondents including questions used to measure the four variables Age, Gender, Education, and Experience, and behavioral factors regard to day per week and minute per day respondents used e-commerce. The second section presents questions related to the eleven variables presented on the theoretical model.

The questionnaires were collected from students of High School and University level in Indonesia. Any questionnaires no satisfying the definition of the target population were removed from the sample. The final samples of 343 questionnaires were used in the study. The final samples were prepared to preliminary analyze using principle components factor analysis to assess the construct validity of the indicators for each of the latent variables and Cronbach's alpha coefficients to assess the internal consistency reliability of the indicators for each of the latent variables.

Furthermore, the result of preliminary analyze was used to reveal: the first, the correlation among variables employed on the study using Pearson Correlation; the second, the gender difference among female and male and generation difference among Z and Y generations using T-Test analysis.

The causal effect analysis using AMOS software was employed to examine the theoretical model. The all of analyses of the study have purpose to investigate the difference adoption of e-commerce technology through the

investigation of the correlation and the causal effect analysis of the variables for two generations Z and Y.

#### V. FINDINGS AND DISCUSSION

##### A. Demographic of Respondent

The demographic, location and technology used, and behavioral variables of respondents regarding to e-commerce adoption will discuss firstly and then the discussion of construct validity and reliability analysis of questionnaires, and finally the discussion of correlation among variables including the discussion the difference among gender and generation.

From analysis of 343 respondents, the type of e-commerce used by respondents is shown on Table I and the frequency of age, gender, and education of respondents is presented on Table II.

TABLE I. TYPE OF E-COMMERCE USED BY RESPONDENTS

Type of E-Commerce	Z generation		Ygeneration	
	Freq.	%	Freq.	%
Online Transaction	156	62.9	38	40.0
Online Shopping	71	28.6	34	35.8
Online Booking	8	3.2	11	11.6
Online Banking	13	5.2	12	12.6
Total	248	100.0	95	100.0

As shown on Table II, the Z generation was on age range of 15 – 19 years old represented by 248 respondents and the Y generation was on age range of 20 – 25 years old represented by 95 respondents.

TABLE II. AGE, GENDER AND EDUCATION OF RESPONDENTS

Generation (Age)	Education		Gender	
Z (15 - 19) 248	Senior High School	182	Male	95
	University	66	Female	153
Y (20 - 25) 95	Senior High School	-	Male	60
	University	95	Female	35

Male on Z Generation is represented by 95 respondents; meanwhile Female is represented by 153 respondents. The Z generation that has level of educations in senior high school is 182 respondents and in university are 66 respondents. In opposite, all of the Y generation or 95 respondents have level of educations in university. Furthermore, male on Y generation is represented by 60 respondents and female is represented by 35 respondents.

Table III presents the location and technology used commonly used by respondents. Table III stated that most of respondents use mobile phone to access e-commerce services and more often this activity was done in home.

TABLE III. LOCATION AND TECHNOLOGY USED BY RESPONDENTS

Technology Used	Generation		Location Used	Generation	
	Z	Y		Z	Y
Mobile phone	244	85	Home	194	81
Laptop/netbook	4	9	School/Univ.	21	11
PC-desktp	-	1	Service point	33	3
Total	248	95		248	95

The data of behavioral variables naming Experience, days per week, and minutes per day respondents used e-commerce technology is shown on Table IV.

TABLE IV. BEHAVIORAL FACTORS IN USING E-COMMERCE

Experience (months)	Generation		Days/Week (days)	Generation	
	Z	Y		Z	Y
<= 1	22	6	1	99	44
2 - 3	23	11	2	41	15
4 - 5	19	6	3	45	8
6 - 7	12	3	4	12	5
8 - 9	23	4	5	8	6
10 - 11	14	5	6	11	7
>= 12	135	60	7	32	10
Total	248	95	Total	248	95
Generation	Minutes/day				
	< 10	10 - 15	16 - 30	> 30	Total
Z	66	77	70	35	248
Y	23	30	24	18	95

### B. Construct Validity and Reliability Analysis of Questionnaires

The result of validity test using Component Factor Analysis and Reliability analysis using Cronbach's Alpha Coefficient is shown on Table V.

TABLE V. CONSTRUCT VALIDITY AND RELIABILITY ANALYSIS OF QUESTIONNAIRES

	Rotated Component Matrix								Cronbach's Alpha
	Component								
	EE-FC	BI-HB	SF-IQ	HM-PE	PV	SQ	SI	TR	
EE2	.728	.075	.273	.138	.121	.212	.141	.175	.894 (Good)
EE1	.719	.020	.200	.201	.194	.124	.131	.104	
EE3	.691	.120	.265	.138	.103	.250	.161	.210	
FC1	.683	.057	.250	.239	.206	.067	.196	.109	.857 (Good)
FC2	.642	.110	.193	.096	.312	.007	.175	.137	
FC3	.585	.223	.228	.045	.276	.069	.102	.223	
BI2	.217	.778	.145	.182	.216	.050	.093	.070	.926 (Excellent)
BI3	.120	.767	.085	.241	.270	.055	.151	.152	
BI1	.171	.751	.118	.222	.284	.061	.107	.130	
HB3	-.091	.718	-.060	.084	-.039	.234	.157	.075	.791 (Acceptable)
HB2	-.026	.708	.098	.117	.078	.182	.281	.104	
HB1	.164	.566	.132	.060	.020	.085	.353	.298	
SF2	.212	.031	.752	.149	.140	.105	.278	.175	.895 (Good)
SF3	.236	.072	.731	.214	.108	.097	.236	.181	
SF1	.174	.186	.690	.233	.164	.078	.157	.149	
IQ2	.249	.025	.622	.117	.203	.274	.008	.215	.829 (Good)
IQ3	.167	.079	.575	.128	.227	.217	.061	.318	
IQ1	.228	.116	.561	.134	.269	.137	.045	.223	
HM2	.019	.224	.167	.769	.059	.104	.131	.125	.817 (Good)
HM3	-.028	.170	-.022	.735	.017	.181	.214	.200	
HM1	.188	.113	.286	.725	.085	.052	.084	.108	
PE1	.347	.064	.138	.523	.387	.144	.104	.233	.884 (Good)
PE2	.333	.077	.127	.486	.436	.093	.148	.187	
PE3	.297	.135	.167	.446	.454	.129	.135	.255	
PV2	.115	.146	.177	.047	.771	.125	.215	.151	.826 (Good)
PV1	.095	.108	.105	.102	.765	.103	.233	.085	
PV3	.191	.181	.209	.107	.602	.163	.252	.220	
SQ2	.084	.135	.101	.062	.055	.864	.165	.135	.896 (Good)
SQ3	.045	.094	.096	.137	.107	.853	.161	.112	
SQ1	.067	.057	.073	.067	.090	.853	.141	.130	
SI2	.064	.212	.054	.110	.158	.154	.853	.069	.876 (Good)
SI3	.082	.179	.059	.158	.195	.176	.799	.067	
SI1	.159	.083	.166	.115	.189	.213	.742	.098	
TR2	.173	.129	.161	.157	.120	.156	.098	.804	.820 (Good)
TR3	.012	.045	.090	.118	.105	.140	.134	.797	
TR1	.103	.139	.200	.171	.134	.140	.022	.751	

### C. Gender and Generation Differences

Gender difference between males and females was calculated using T-test and the result was shown on Table VI.

TABLE VI. MEAN DIFFERENCES BETWEEN MALES AND FEMALES

	Levene's Test for Equality of Variances		t	Sig. (2-tailed)	Mean for Males - Mean for Females
	F	Sig.			
A	8.902	.003	4.658	.000	1.041
EDU	1.668	.197	3.942	.000	.209
E	.193	.661	-.685	.494	-.162
D/W	.299	.585	-.726	.468	-.166
M/D	.001	.970	-.569	.570	-.065
SF	1.179	.278	-2.328	.021	-.16400
IQ	5.864	.016	-2.449	.015	-.16370
SQ	.099	.753	-1.508	.132	-.11438
TR	.196	.659	.896	.371	.06207
HM	.960	.328	-1.220	.223	-.08662
PE	.006	.937	-1.170	.243	-.08365
EE	.369	.544	-1.970	.050	-.14132
SI	.005	.944	.287	.774	.02145
FC	.018	.892	-.561	.575	-.03896
PV	1.147	.285	-.784	.434	-.05446
HB	.809	.369	-.404	.686	-.03556
BI	.120	.729	.473	.637	.03878

Similar to Table VI, Table VII presents generation difference between Z and Y generations.

TABLE VII. MEAN DIFFERENCES BETWEEN Z AND Y GENERATION

	Levene's Test for Equality of Variances		t	Sig. (2-tailed)	Mean for Z - Mean for Y Generations
	F	Sig.			
G	.262	.609	4.233	.000	.249
E	.152	.697	-.942	.347	-.247
D/W	.981	.323	.242	.809	.062
M/D	1.410	.236	-.967	.334	-.123
ASF	.612	.435	1.202	.230	.09474
AIQ	1.949	.164	-.165	.869	-.01241
ASQ	.190	.663	.468	.640	.03959
ATR	1.829	.177	-1.509	.132	-.11593
AHM	3.202	.074	-2.282	.023	-.17917
APE	1.042	.308	.456	.649	.03633
AEE	.229	.633	.676	.499	.05422
ASI	.469	.494	-2.072	.039	-.17108
AFC	1.014	.315	-1.112	.267	-.08584
APV	.001	.974	-.635	.526	-.04926
AHB	.039	.843	-1.678	.094	-.16355
ABI	2.296	.131	-1.022	.307	-.09311

### D. Correlation Analysis

The graphical representation of correlation among variables presents on Figure 2 and is derived from Table VIII (statistically significant correlation, Table VI (statistically significant difference between males and females) and Table VII (statistically significant difference between Z and Y generations).

From Figure 2, it can be concluded that:

1) There are a positive correlation among variables: Effort Expectancy, Satisfaction, Perceived Information Quality, Perceived Service Quality, Trust, Performance Expectancy, Hedonic Motivation, Social Influence, Facilitating Conditions, Habit, Price Value, and Behavioral Intention.

2) Individuals with high experience have more: easier, satisfy, believe in getting certain information and service quality, trust, believe it help them to attain personal gains, hedonic motivation, influenced by friends and family, believe

TABLE VIII. CORRELATION ANALYSIS OF VARIABLES

		Variables														
	A	E	D/W	M/D	ASF	AIQ	ASQ	ATR	AHM	APE	AEE	ASI	AFC	APV	AHB	ABI
A	1	.066	-.037	.081	-.034	-.037	-.072	.041	.139*	-.033	-.015	.018	.067	.003	.045	.028
E		1	.300**	.115*	.283**	.254**	.126*	.219**	.170**	.213**	.301**	.130*	.293**	.185**	.170**	.213**
D/W			1	.091	.105	.077	.029	.086	.066	.047	.103	.146**	.146**	.122*	.221**	.145**
M/D				1	.064	.105	.023	.064	.239**	.078	.129*	.099	.174**	.141**	.156**	.114*
ASF					1	.610**	.329**	.465**	.421**	.543**	.562**	.415**	.543**	.472**	.298**	.389**
AIQ						1	.367**	.502**	.390**	.523**	.561**	.354**	.532**	.483**	.273**	.357**
ASQ							1	.375**	.301**	.333**	.342**	.414**	.270**	.335**	.342**	.266**
ATR								1	.418**	.483**	.416**	.317**	.401**	.417**	.338**	.380**
AHM									1	.522**	.373**	.385**	.375**	.376**	.388**	.448**
APE										1	.576**	.438**	.554**	.548**	.322**	.479**
AEE											1	.387**	.637**	.488**	.263**	.380**
ASI												1	.392**	.502**	.462**	.448**
AFC													1	.527**	.274**	.422**
APV														1	.362**	.466**
AHB															1	.636**
ABI																1

that their technical infrastructure can support them, habit, acceptable with price value and intention in using e-commerce technology. Individuals with high experience also have high level of duration in day per week and minute per day in using e-commerce technology.

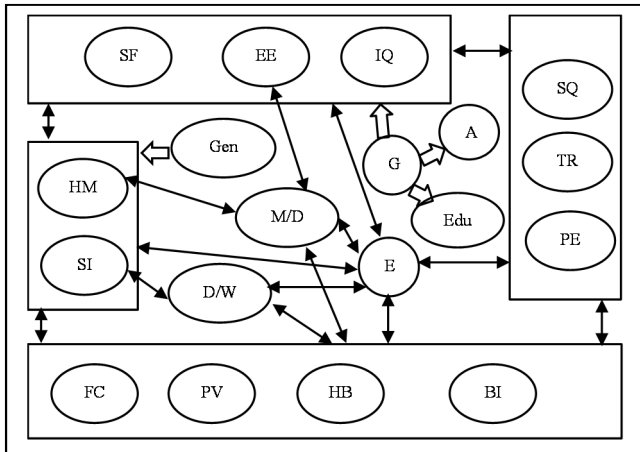

Fig. 2. Graphical Representation of Correlations and Mean Difference of Gender and Generation

3) Individuals with the high level of Social Influence in using e-commerce have high number of day each week in using it.

4) The variables Effort Expectancy, Satisfaction, Perceived Information Quality and Age have significantly difference due to Gender. It means that males and females have difference perception on finding easier in using e-commerce, feeling satisfy, perception on finding certain information, and on age in using e-commerce technology.

5) The Significant difference due to gender are found on Satisfaction, Effort Expectancy, Information Quality, Age, and Education. It means that males are more older and have higher education than females in this study. Furthermore, males are less satisfy and finding more difficulty in using e-commerce technology and hold less information with better quality than females.

6) The Significant difference due to Z and Y generations where found on Hedonic Motivation and Social Influence and not on else. It means that Z generations hold less hedonic

motivation and influenced by friends and family in using e-commerce than Y generation.

E. Causal Effect Analysis

The result of statistical analysis for the theoretical model is shown on Figure 3. The analysis was conducted by AMOS software. Figure 3 shows that Trust, Hedonic Motivation, Performance Expectancy, Effort Expectancy, Price Value, and Facilitating Condition have effect on Behavioral Intention with positive, small but not statistically significant at a level of 0.05 or less. According to [25] S (small), M (medium), and L (large) were interpreted as magnitudes less than 0.1, 0.1 to less than 0.5, and 0.5 or greater, respectively. Furthermore, Perceived Information Quality, Perceived Service Quality, Satisfaction, and Social Influence have effect on Behavioral Intention with negative, small but not statistically significant at level of 0.05 or less. In conjunction with the results of correlation analysis, these causal effect analysis results state that H1, H2, H3, H4, H5, H6, H7, H8, H9, and H10 are partially support.

Only Habit has effect on Behavioral Intention with positive, large, and statistically significant at level of 0.001. The reference [25] stated that the standardized effect using \*\*\* related to statistically significant at level of 0.001. In conjunction with the result of correlation analysis for the relation of Habit and Behavioral Intention, this causal effect analysis result states that H11 are fully support.

F. Causal Effect Analysis for Z and Y Generations

The causal effect analysis of the model for Z and Y generation is shown on Table IX. In the view of comparison table, firstly, for the two generations, Habit has positive, large, and statistically significant effect on Behavioral Intention. Furthermore, the results of the causal effect analysis for two generations are equally for Perceived Information Quality, Trust, Satisfaction, and Facilitating Conditions on Behavioral Intention.

Secondly, the difference results on causal effect analysis for two generations are found on Perceived Service Quality, Hedonic Motivation, Performance Expectancy, Effort Expectancy, Price Value, and Social Influence. For Z generation, Performance Expectancy and Price Value have positive, medium, and not statistically significant on Behavioral Intention. In other hand, for Y generation, Perceived Expectancy has positive, small, and not statistically

TABLE IX. CAUSAL EFFECTS ANALYSIS FOR Z AND Y GENERATIONS

Effect	Z generation (N = 248)				Y generation (N =95)			
	Unstandardized Estimate	Statistical Significance	Standardized Estimate	Magnitude	Unstandardized Estimate	Statistical Significance	Standardized Estimate	Magnitude
IQ→ BI	-.084	NS	-.071	S	-.023	NS	-.017	S
SQ→ BI	-.112	NS	-.107	M	-.082	NS	-.060	S
TR→ BI	.042	NS	.034	S	.162	NS	.092	S
SF→ BI	-.021	NS	-.016	S	-.043	NS	-.033	S
HM→ BI	-.042	NS	-.040	S	.449	NS	.264	M
HB→ BI	.611	***	.647	L	.703	***	.627	L
PE→ BI	.254	NS	.217	M	.106	NS	.097	S
EE→ BI	.005	NS	.004	S	-.074	NS	-.063	S
PV→ BI	.216	NS	.189	M	-.147	NS	-.103	M
SI→ BI	-.046	NS	-.045	S	.045	NS	.034	S
FC→ BI	.164	NS	.136	M	.164	NS	.126	M

Note: \*\*\* indicate statistical significance at a level of 0.001 and NS indicates not statistically significant at a level of 0.05 or less.

significant on Behavioral Intention. Price Value has negative, medium, and not statistically significant on Behavioral Intention.

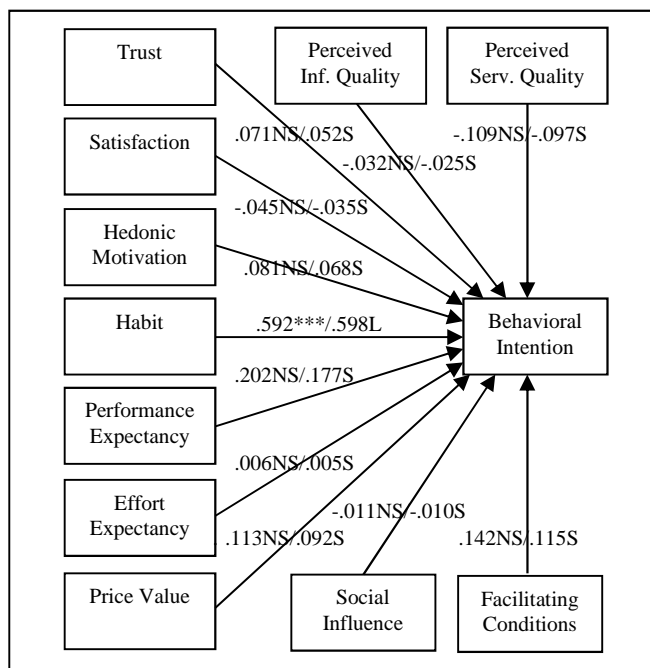

Fig. 3. Causal Effect Analysis for the Model

The other result in the difference, for z generation, Hedonic Motivation and Social Influence have negative, small, and not statistically significant on Behavioral intention. In other hand, for Y generation, Hedonic Motivation has positive, medium, and not statistically significant on Behavioral intention. Social Influence has positive, small, and not statistically significant on Behavioral Intention.

The last result in the difference, for Y generation, Perceived Service Quality and Effort Expectancy have negative, small, and not statistically significant on Behavioral Intention. Meanwhile, for Z generation, Perceived Service Quality has negative, medium, and not statistically significant on Behavioral Intention. Effort Expectancy has positive, small, and statistically significant on Behavioral Intention.

This study has not devoted new results regarded to correlation analysis of variables and causal effect on Behavioral Intention. The results were partially and fully support on the H1 – H11 hypotheses. However, comparing of two generations Z and Y in correlation and causal effect analysis represents new findings have not reported on previous studies. It is necessary to emphasize that these new findings entail to be validate in future studies.

ACKNOWLEDGMENT

I would like to gratefully acknowledge the Ministry of Research, Technology and Higher Education of the Republic of Indonesia, which provide research project including the support from Department of Information Systems, Soegijapranata Catholic University, Indonesia.

REFERENCES

- [1] S. Kemp. (January 2019) Special Reports, Digital 2019: Global Internet Use Accelerates. [Online]. Available: <https://wearesocial.com/blog/2019/01/digital-2019-global-internet-use-accelerates>.
- [2] J. Barney. (January 2019) The Ultimate eCommerce Infographic 2019 [Online]. Available: <https://www.einsteinmarketer.com/e-commerce-infographic-2019/>.
- [3] APJII. (May 2019). Laporan Survei: Penetrasi dan Profil Perilaku Pengguna Internet Indonesia. [Online]. Available: <https://apjii.or.id/survei2018s>.
- [4] B. Harnadi, "An investigation of the adoption of online game technologies in Indonesia," International Journal of Gaming and Computer-Mediated Simulations, vol.9, issue 1, pp. 1–27, 2017.
- [5] S. K. Sharma and M. Sharma, "Examining the role of trust and quality dimensions in the actual usage of mobile banking services: An empirical investigation," International Journal of Information Management, vol. 44, pp. 65-75, 2019.
- [6] A. M. Baabdullah, A. A. Alalwan, N. P. Rana, H. Kizgin, P. Patil, "Consumer use of mobile banking (M-Banking) in Saudi Arabia: Towards an integrated model," International Journal of Information Management, vol. 44, pp. Pages 38-52, 2019.
- [7] M. A. Shareef, A. Baabdullah, S. Dutta, V. Kumar, Y. K. Dwivedi, "Consumer adoption of mobile banking services: An empirical examination of factors according to adoption stages," Journal of Retailing and Consumer Services, vol. 43, 2018.
- [8] S. F. Verkijika, "Factors influencing the adoption of mobile commerce applications in Cameroon," Telematics and Informatics, Vol. 35, Issue 6, pp. 1665-1674, 2018.
- [9] H. R. Marriott, M. D. Williams, "Exploring consumers perceived risk and trust for mobile shopping: A theoretical framework and empirical study," Journal of Retailing and Consumer Services, vol. 42, pp. 133-146, 2018.

- [10] S. Agrebi, J. Jallais, "Explain the intention to use smartphones for mobile shopping, *Journal of Retailing and Consumer Services*," vol. 22, pp. 16-23, 2015.
- [11] A. A. Alalwan, Y. K. Dwivedi, N. P. Rana, "Factors influencing adoption of mobile banking by Jordanian bank customers: Extending UTAUT2 with trust," *International Journal of Information Management*, vol. 37, Issue 3, pp. 99-110, 2017.
- [12] F. M-Leiva, S. C-Climent, F. L-Cabanillas, "Determinants of intention to use the mobile banking apps: An extension of the classic TAM model," *Spanish Journal of Marketing - ESIC*, vol. 21, Issue 1, pp. 25-38, 2017.
- [13] M. N. Masrek, I. S. Mohamed, N. M. Daud, N. Omar, "Technology Trust and Mobile Banking Satisfaction: A Case of Malaysian Consumers," *Procedia - Social and Behavioral Sciences*, vol. 129, pp. 53-58, 2014.
- [14] A. A. Alalwan, Y. K. Dwivedi, N. P. Rana, R. Algharabat, "Examining factors influencing Jordanian customers' intentions and adoption of internet banking: Extending UTAUT2 with risk," *Journal of Retailing and Consumer Services*, vol. 40, pp.125-138, 2018.
- [15] V. Venkatesh, J. Y. L. Thong, & X. Xu, "Extending the Unified Theory of Acceptance and Use of Technology", *MIS Quarterly*, vol. 36, no. 1, pp. 157-178, 2012.
- [16] P. K. Chopdar, N. Korfiatis, VJ. Sivakumar, and M. D. Lytras, "Mobile shopping apps adoption and perceived risks: A cross-country perspective utilizing the Unified Theory of Acceptance and Use of Technology," *Computers in Human Behaviour*, vol. 86, pp. 109-128, 2018.
- [17] W. Boonsiritomachai, K. Pitchayadejanant, "Determinants affecting mobile banking adoption by generation Y based on the Unified Theory of Acceptance and Use of Technology Model modified by the Technology Acceptance Model concept," *Kasetsart Journal of Social Sciences*, 2017.
- [18] A. M. Baabdullah, A. A. Alalwan, N. P. Rana, H. Kizgin, P. Patil, "Consumer use of mobile banking (M-Banking) in Saudi Arabia: Towards an integrated model," *International Journal of Information Management*, vol. 44, pp. 38-52, 2019.
- [19] F. D. Davis, "Perceived Usefulness, Perceived Ease of Use, and User Acceptance of Information Technology," *Management Information Systems Quarterly*, vol. 13, no. 3, pp. 319-340, 1989.
- [20] V. Venkatesh, M. G. Morris, G. B. Davis, and F. D. Davis, "User acceptance of information technology: toward a Unified View," *MIS Quarterly*, vol. 27, no. 3, pp. 425-479, 2003.
- [21] C. Martins, T. Oliveira, A. Popovič, "Understanding the Internet banking adoption: A unified theory of acceptance and use of technology and perceived risk application," *International Journal of Information Management*, vol. 34, Issue 1, pp. 1-13, 2014.
- [22] K. A. Alshare, and Abeer A. Mousa, "The Moderating Effect of Espoused Cultural Dimensions on Consumer's Intention to Use Mobile Payment Devices," *Thirty Fifth International Conference on Information Systems, Auckland*, pp. 1-15, 2014.
- [23] T. Zhou, Y. Lu, B. Wang, "Integrating TTF and UTAUT to explain mobile banking user adoption," *Computers in Human Behavior*, vol 26, Issue 4, pp. 760-767, 2010.
- [24] B. Hernández, J. Jiménez, and M. J. Martín, "Age, gender and income: Do they really moderate online shopping behaviour?" *Online Information Review*, vol. 35, no. 1, pp. 113-133, 2011.
- [25] J. Cohen, *Statistical power analysis for the behavioral sciences* (2nd ed.). New York, NY: Academic Press, 1988

# [ICSEC 2019] Your paper #1570584036 ('The Difference Adoption of E-Commerce Technology Among Z and Y Generations')



icsec2019@phuket.psu.ac.th via edas.info

to me, Albertus, FX

Fri, Aug 23, 5:36 PM



Dear Mr. Bernardinus Harnadi:

Congratulations - your paper #1570584036 ('The Difference Adoption of E-Commerce Technology Among Z and Y Generations') has been accepted for presentation in **ICSEC 2019**, and will be published in the Proceedings of **ICSEC 2019**. All presented papers will be submitted to IEEE Xplore.

Please reflect the reviewers' comments into your final manuscript, the detail reviews are below or can be found at <https://edas.info/showPaper.php?m=1570584036>, using your EDAS login name [bharnadi@unika.ac.id](mailto:bharnadi@unika.ac.id).

Please also consider 4 mandatory steps for authors in submitting the camera-ready manuscript:

1. Registration and Payment Please be reminded that the due date for early bird registration is 16 October **2019**. At least one author has to register for the conference. Payment and registration details can be found at <https://www.icsec2019.org/registration.php>.
2. Final Manuscript Preparation Papers must be written on A4-format page according to the IEEE template Manuscripts of minimum four (4) pages and up to six (6) pages in length. Submissions exceeding 6 pages will be charged extra page length, 50 US Dollars for each one additional page. Maximum accepted pages are ten (10) pages. Papers should NOT have page numbers, headers, and footers.
3. IEEE PDF eXpress (IEEE Xplore compatible) Your revised manuscript must be compatible with IEEE Xplore. Please check with PDF eXpress [www.pdf-express.org](http://www.pdf-express.org) using the Conference ID: 47112XP.
4. Camera-Ready Paper Upload and Copyright Transfer After passing the IEEE Xplore compatible, the camera-ready manuscript should be submitted in the same manner as the review manuscript using EDAS at <https://edas.info/showPaper.php?m=1570584036> before 16 September **2019**. Electronic copyright form should also be submitted electronically through EDAS.

Should you have any question, please do not hesitate to contact us. We look forward to seeing you at the Conference.

We look forward to seeing you at the conference.

Best Regards,

**ICSEC 2019** Program Committee Chairs

## ICSEC 2019 1

### Comment for Authors: Please explain to the Author for revision.

Please clarify more how important whether the research reveal the different of adoption between those two mentioned generation. How is the pain point that this research can solve. The author mentioned that the practitioner will able to design campaign based on the different among them. but in the background showed in introduction and literature did not tell about it at all. In the title say that the research is conducted about adoption but the proposed theoretical model i was mentioned about behavioral intention. I do not think that Adoption and Behavioral Intention are the same stage. Moreover the author did not show the literature review of Behavioral Intention. The author mentioned that in order to improve validity and reliability then this research adapted existing questions. However how can you be sure that in this context this instrument is valid and reliable. why the author did not test it again. I did not see theoretical discussion in the late part of paper.

## ICSEC 2019 2

### Comment for Authors: Please explain to the Author for revision.

The adoption on e-commerce technology is an interesting domain especially among Gens Z and Y in the context of Indonesia. The study provides the theoretical understanding of the e-commerce adoption technology; and addresses the adoption factors and their relationships. There are some issues that the author(s) may need to look into:

- How the author(s) came up with the final samples of 343? Why 343? What were the collection procedure? Random sampling? How do the authors select the students?
- Under the section V. RESULTS AND DISCUSSION, for the discussion part, try to explain "What do your results mean?", (b) how they relate to the literature, and (c) contextualize the contribution of your study.
- Please also look into the typo errors and spelling mistakes.

## ICSEC 2019 3

### Comment for Authors: Please explain to the Author for revision.

The paper provides a result of a survey on 343 Indonesian technology adopters. The authors aim at exploring the difference between two age categories in accepting e-commerce technology. However, the content of the paper seems to cover more than the stated objective. The paper has a major part investigating the model in Figure 1. Data collection and data analysis seems to be carried on in a good way. However, the research design is incomplete and not fully presented. For instance, hypotheses should be formulated for testing. Survey detail should be presented. Formulation of dependent variables needs more details. It seems to me that the authors try to put too much into a 6 page long paper. The suggestion is to focus on one single research objective, having proper hypotheses and relevant background. With a better presentation of the research, I believe a good quality article can be expected.



Dokumen pendukung luaran Tambahan #3

Luaran dijanjikan: Hak Cipta

Target: granted

Dicapai: Bersertifikat

Dokumen wajib diunggah:

1. Deskripsi dan spesifikasi ciptaan
2. Sertifikat hak cipta

Dokumen sudah diunggah:

1. Sertifikat hak cipta
2. Sertifikat hak cipta

Dokumen belum diunggah:

-

Jenis Ciptaan : Karya Tulis (Artikel)

Judul Ciptaan : The Difference Adoption Of E-Commerce Technology Among Z And Y Generations

Pencipta :

FX. Hendra Prasetya, ST, MT; Bernadinus Harnadi, Ph.D; Albertus Dwi Yoga Widianoro, S.Kom, M.Kom

Deskripsi Ciptaan:

Artikel ini menganalisis perbedaan adopsi teknologi E-Commerce antara generasi Z dan Y. Analisis berdasarkan model adopsi yang diajukan dengan menggunakan variabel Perceived Information Quality, Perceived Service Quality, Trust, Satisfaction, Hedonic Motivation, Performance Expectancy, Effort Expectancy, Price Value, Social Influence, Habit, and Facilitating Conditions. Hasil Analisis menyatakan bahwa seluruh variabel yang digunakan berelasi satu sama lain. Terdapat perbedaan adopsi antara generasi Z dan Y, dimana generasi Z kurang memiliki motivasi hedonik/kesenangan dan kurang dipengaruhi oleh teman dan keluarga dalam menggunakan teknologi E-Commerce.

Spesifikasi Ciptaan :

# The Difference Adoption of E-Commerce Technology among Z and Y Generations

Bernardinus Harnadi  
Department of Information Systems  
Soegijapranata Catholic University  
Semarang, Indonesia  
bharnadi@unika.ac.id

Albertus Dwiyoga  
Department of Information Systems  
Soegijapranata Catholic University  
Semarang, Indonesia  
yoga@unika.ac.id

Fx. Hendra Prasetya  
Department of Information Systems  
Soegijapranata Catholic University  
Semarang, Indonesia  
hendra@unika.ac.id

**Abstract**— The rapid growth of e-commerce transactions among Y and Z generations in Indonesia goes along with the large number of internet users on both of the generations. Indonesia has become a potential market for the digital creative industry, especially to applications of online payments, online shopping, online booking, and online banking. In-depth investigations into these two generations in the form of developing e-commerce technology adoption models will provide valuable contributions in the development of models and implementation of e-commerce industries in Indonesia. This study aims to obtain factors that influence the acceptance of generation Z and Y against e-commerce technology and reveal the differences in their acceptance of it. Investigation was done by collecting 343 questionnaires in age range of Y and Z generations. The results of this study reveal that all variables employing in the model naming Satisfaction, Trust, Perceived Information Quality, Perceived Service Quality, Performance Expectancy, Perceived Ease of Use, Hedonic Motivation, Social Influence, Price Value, Habit, and Facilitating Conditions have statistically significantly correlation to Behavioral Intention and to each other. The significantly difference of adoption of e-commerce technology among Z and Y generations are only found on Hedonic Motivation and Social Influence. The other difference on gender is found on Age, Education, Satisfaction, Perceive Ease of Use, and Perceive Information Quality. This study can contribute to who have concern on enhance adopting of e-commerce technology especially to the two generations, especially developers of e-commerce application considering the factors that have correlation to intention to use e-commerce.

**Keywords**—adoption technology, e-commerce, Z generation, Y generation

## I. INTRODUCTION (HEADING 1)

According to Special Reports, Digital 2019 [1], the total population of the world is 7.676 billion with 5.112 billion of its are unique mobile users and 4.388 billion of its are internet users. E-commerce Infographic 2019 by Einstein Marketer report [2] stated that the mobile internet as share of total e-commerce transactions are 67.2% in 2019 and estimated up to 70.4% & in 2020. In Indonesia context, the survey conducted by APJII in 2018[3] stated that 64.8% of Indonesia population (264. 16 million) or 171. 17 million is internet users. Regard to the survey, 91 % of Z generation in the age range of 15 – 19 years old are internet users, whereas Y generation in the age range of 20 – 24 years old are 85.5%

The penetration of online shopping in Indonesia is 36.6% of internet users [3] that separated on four online shopping applications including Shopee, Bukalapak, Lazada, and Tokopedia.

The purpose of this research is to investigate the difference among Z and Y generation in accepting e-commerce technology through studying factors related to intention to use e-commerce technology. The study address research questions: what are the factors that are related to adopting e-commerce technology among Z and Y generations and; what are the relationships among these factors?

The outcomes of the study are expected to contribute to a theoretical understanding of the adopting e-commerce technology and to provide advice for practitioners who have interests in increasing of e-commerce adoption among the two generations. Furthermore the study also has contribution to the practice. The practitioners will gain more understanding about human factors, such as personality traits, that affect a user's intentions of e-commerce. Other factors reflecting the different adoption between Z and Y generations and male and female may enable practitioners to design campaign and other efforts based on the different motivation among them.

## II. FACTORS RELATED TO ADOPTING ON E-COMMERCE IN PREVIOUS STUDIES

Reviewing literatures in previous studies are conducted on the adoption technology of e-commerce. Several models are employed on the studies including TAM, TPB, and UTAUT. The main objectives of these studies concern the exploration and understanding of human behaviors related to adopting and using e-commerce. The discussion on variables supported direct antecedent on behavioral intention to use e-commerce technology is discussed in detail. In the context of adoption of ecommerce technology Behavioral Intention can be defined as “The extent to which the user intends to use a system in the future. [4]”

### A. Perceived Information Quality and Perceived Service Quality

According to [5], Perceived Information quality is the quality of relevance, sufficiency, accuracy and timeliness of information got by users. meanwhile Baabullah (2019) defined Perceived Service Quality as “the overall support delivered by the service provider” to ascertain empathy, assurance, and responsiveness delivered to users.

References [5] and [6] conducted studies on M-banking acceptance and employed Perceived Information Quality and Perceived Service Quality as variables having significantly correlation to m-banking acceptance. Meanwhile reference [7] also conduct study on m-banking acceptance and reveal that Perceived Information Quality has significantly

correlation to m-banking acceptance. For these reasons, Perceived Information Quality and Perceived Service Quality are predicted to have correlation with Behavioral Intention to use e-commerce technology (H1 and H2).

### B. Trust and Satisfaction

Trust and Satisfaction were importance variables on e-commerce studies. Trust was defined by [8] as “the extent to which an individual believes that using m-commerce is secure and has no privacy threats.” According to [5], Satisfaction is acquired by positive experience with using of a service. References [9], [8], and [10] conducted study on mobile shopping acceptance and References [5], [7], [8], [11], [12], and [13] conducted study on m-banking acceptance verified that Trust and Satisfaction were importance variables in e-commerce study. References [5] and [10] reveal that Satisfaction has significantly correlation to m-banking and m-shopping acceptance, respectively. Meanwhile, References [11] and [12] reveal that Trust has significantly correlation to m-banking acceptance. Similarly Reference [9] also reveal that Trust has significantly correlation to m-shopping acceptance. Surprisingly, the study conducted by [13] reveals that Trust have relation to Satisfaction. On the study of adoption mobile internet, Reference [14] revealed that Trust also has significantly correlation to Behavioral Intention to use e-commerce technology. For these reasons, Trust and Satisfaction are predicted to have correlation with Behavioral Intention to use e-commerce technology (H3 and H4).

### C. Hedonic Motivation

References [15] defined Hedonic Motivation as the fun or enjoy derived with use of a technology. Several researchers used Perceived Enjoyment ([4], [10], [14]) and Flow Experience ([4]) to refer Hedonic Motivation. According to [8], [10], [11], [14], [15], [16], [17], and [18], Hedonic Motivation has significantly correlation to e-commerce acceptance. For these reasons, Hedonic Motivation is predicted to have correlation with Behavioral Intention to use e-commerce technology. [H5 and H6]

### D. Performance Expectancy and Effort Expectancy

Performance Expectancy is defined by [4] as “the extent to which an individual believes that using the system will help them to attain personal gains”. Effort Expectancy is defined by [15] as “the degree of ease associated with consumers’ use of technology”. Performance Expectancy and Effort Expectancy have proven as main variables on adoption technology researches. On TAM model by [19], these variables naming Perceived Usefulness and Perceived Ease of Use have significantly correlation to Intention through variable Attitude. On the research conducted by [20], Attitude was not employed. He argues that without Attitude, the two variables Performance Expectancy and Effort Expectancy have significantly correlation to Intention. Several researchers on e-commerce adoption ([10], [11], [15], [16], [21], [22]) stated that Performance Expectancy has significantly correlation to Behavioral Intention to use e-commerce technology, meanwhile References [18] and [23] reveal that Performance Expectancy has significantly correlation to Use Behavior of e-commerce technology. Meanwhile [12] and [24] stated that Performance Expectancy has significantly correlation to Behavioral Intention to use e-commerce through Attitude. On the studies

of adoption of mobile internet conducted by [14] and online gaming technology conducted by [4], they revealed that Performance Expectancy has significantly correlation to Behavioral Intention to use e-commerce technology.

Effort Expectancy was also used as variable in model to predict Behavioral Intention to use e-commerce technology. The study conducted by [11], [14], [15], [16], and [21] stated that Effort Expectancy has significantly correlation to Behavioral Intention to use e-commerce. Reference [12] also stated that Effort Expectancy has significantly correlation to Behavioral Intention to use e-commerce through Attitude. For these reasons, Performance Expectancy and Effort Expectancy are predicted to have correlation with Behavioral Intention to use e-commerce technology (H7 and H8).

### E. Price Value and Facilitating Conditions

Price Value was defined by [15] as “consumers’ cognitive tradeoff between the perceived benefits of the applications and the monetary cost for using them”. References [11], [14], [15], and [16] reveal that Price Value has significant correlation to Behavioral Intention to use e-commerce technology. Reference [18] also revealed that Price Value has significant correlation to Use Behavior in using e-commerce technology.

According to [4], Facilitating Conditions is “the extent to which an individual believe that there is organizational and technical infrastructure supporting in using a systems”. The studies conducted by [8], [15], and [16] stated that Facilitating Conditions has correlation to Behavioral Intention to use e-commerce technology. References [15] and [18] revealed that Facilitating Conditions also has significant correlation to Use Behavior in using e-commerce technology. For these reasons, Price Value and Facilitating Conditions are predicted to have correlation with Behavioral Intention to use e-commerce technology (H9 and H10).

### F. Social Influence and Habit

Reference [22] defined Social Influence as “the perceived social pressure from close members to the individual to perform or not to perform the behavior in question”. The studies conduct by [15], [21], and [22] reveal that Social Influence has significant correlation to Behavioral Intention to use e-commerce technology.

Habit was defined by [15] as “the extent to which people tend to perform behaviors automatically because of learning and the behaviors was the results of prior experiences.” References [15] and [16] conducted study in adoption e-commerce technology and revealed that Habit has correlation to Behavioral Intention to use e-commerce technology. In other hand, [15] and [18] revealed that Habit also has correlation to Use Behavior in using e-commerce technology. For these reasons, Social Influence and Habit is predicted to have correlation with Behavioral Intention to use e-commerce technology (H11 and H12).

## III. PROPOSED MODEL AND HYPOTHESIS

Based on the literature reviews, a theoretical model is proposed on Figure 1. In the theoretical model there are eleven independent variables relating to one dependent variable (Behavioral Intention). The eleven variables (Perceived Information Quality, Perceived Service Quality, Trust, Satisfaction, Hedonic Motivation, Performance

Expectancy, Effort Expectancy, Price Value, Social Influence, Habit, and Facilitating Conditions) had significant effect on Behavioral intention.

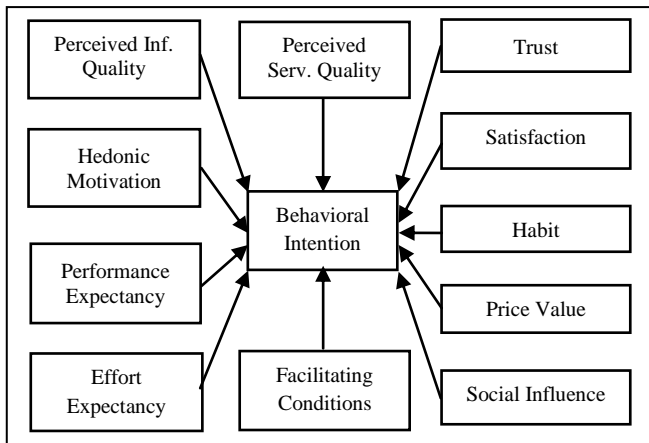

Fig. 1. Proposed Theoretical Model.

#### IV. METHODOLOGY

The study is a field study which aims to develop theoretical knowledge with practical implications concerning factors that influence the use of e-commerce platform among the target population of individuals with e-commerce experience currently on Z and Y generations in Indonesia. The questionnaires were collected from students on high schools and universities. The students are in age range of 15 - 25 years.

The literature review presents a comprehensive survey of previous studies related to the variables that influence the adoption and use of e-commerce by individuals. Based on this review a theoretical model is developed which incorporates the important variables and their relationships.

A self-administered questionnaire is used to measure the variables. In order to improve the validity and reliability of measures wherever possible the questionnaire adapts existing measuring instruments used in previous studies. The questionnaire was prepared in two sections. The first section presents questions related to profile of the respondents including questions used to measure the four variables Age, Gender, Education, and Experience, and behavioral factors regard to day per week and minute per day respondents used e-commerce. The second section presents questions related to the eleven variables presented on the theoretical model.

The questionnaires were collected from students of High School and University level in Indonesia. Any questionnaires no satisfying the definition of the target population were removed from the sample. The final samples of 343 questionnaires were used in the study. The final samples were prepared to preliminary analyze using principle components factor analysis to assess the construct validity of the indicators for each of the latent variables and Cronbach's alpha coefficients to assess the internal consistency reliability of the indicators for each of the latent variables.

Furthermore, the result of preliminary analyze was used to reveal: the first, the correlation among variables employed on the study using Pearson Correlation; the second, the gender difference among female and male and generation difference among Z and Y generations using T-Test analysis. The all of analyses of the study have purpose to investigate

the difference adoption of e-commerce technology through the investigation of the correlation of the variables relating to two generations Z and Y.

#### V. RESULTS AND DISCUSSION

##### A. Demographic of Respondent

The demographic, location and technology used, and behavioral variables of respondents regarding to e-commerce adoption will discuss firstly and then the discussion of construct validity and reliability analysis of questionnaires, and finally the discussion of correlation among variables including the discussion the difference among gender and generation.

From analysis of 343 respondents, the type of e-commerce used by respondents is shown on Table I and the frequency of age, gender, and education of respondents is presented on Table II.

TABLE I. TYPE OF E-COMMERCE USED BY RESPONDENTS

Type of E-Commerce	Z generation		Y generation	
	Freq.	%	Freq.	%
Online Transaction	156	62.9	38	40.0
Online Shopping	71	28.6	34	35.8
Online Booking	8	3.2	11	11.6
Online Banking	13	5.2	12	12.6
Total	248	100.0	95	100.0

As shown on Table II, the Z generation was on age range of 15 - 19 years old represented by 248 respondents and the Y generation was on age range of 20 - 25 years old represented by 95 respondents. Male on Z Generation is represented by 95 respondents; meanwhile Female is represented by 153 respondents. The Z generation that has level of educations in senior high school is 182 respondents and in university are 66 respondents. In opposite, all of the Y generation or 95 respondents have level of educations in university. Furthermore, male on Y generation is represented by 60 respondents and female is represented by 35 respondents.

TABLE II. AGE, GENDER AND EDUCATION OF RESPONDENTS

Generation (Age)	Education		Gender	
Z (15 -19) 248	Senior High School	182	Male	95
	University	66	Female	153
Y (20 - 25) 95	Senior High School	-	Male	60
	University	95	Female	35

Table III presents the location and technology used commonly used by respondents. Table III stated that most of respondents use mobile phone to access e-commerce services and more often this activity was done in home.

TABLE III. LOCATION AND TECHNOLOGY USED BY RESPONDENTS

Technology Used	Generation		Location Used	Generation	
	Z	Y		Z	Y
Mobile phone	244	85	Home	194	81
Laptop/netbook	4	9	School/Univ.	21	11
PC-deskstop	-	1	Service point	33	3
Total	248	95		248	95

The data of behavioral variables naming Experience, days per week, and minutes per day respondents used e-commerce technology is shown on Table IV.

TABLE IV. BEHAVIORAL FACTORS IN USING E-COMMERCE

Experience (months)	Generation		Days/Week (days)	Generation	
	Z	Y		Z	Y
<= 1	22	6	1	99	44
2 - 3	23	11	2	41	15
4 - 5	19	6	3	45	8
6 - 7	12	3	4	12	5
8 - 9	23	4	5	8	6
10 - 11	14	5	6	11	7
>= 12	135	60	7	32	10
Total	248	95	Total	248	95
Generation	Minutes/day				
	< 10	10 - 15	16 - 30	> 30	Total
Z	66	77	70	35	248
Y	23	30	24	18	95

### B. Construct Validity and Reliability Analysis of Questionnaires

The result of validity test using Component Factor Analysis and Reliability analysis using Cronbach's Alpha Coefficient is shown on Table V.

TABLE V. CONSTRUCT VALIDITY AND RELIABILITY ANALYSIS OF QUESTIONNAIRES

	Rotated Component Matrix								Cronbach's Alpha
	Component								
	EE-FC	BI-HB	SF-IQ	HM-PE	PV	SQ	SI	TR	
EE2	.728	.075	.273	.138	.121	.212	.141	.175	.894 (Good)
EE1	.719	.020	.200	.201	.194	.124	.131	.104	
EE3	.691	.120	.265	.138	.103	.250	.161	.210	
FC1	.683	.057	.250	.239	.206	.067	.196	.109	.857 (Good)
FC2	.642	.110	.193	.096	.312	.007	.175	.137	
FC3	.585	.223	.228	.045	.276	.069	.102	.223	
BI2	.217	.778	.145	.182	.216	.050	.093	.070	.926 (Excellent)
BI3	.120	.767	.085	.241	.270	.055	.151	.152	
BI1	.171	.751	.118	.222	.284	.061	.107	.130	
HB3	-.091	.718	-.060	.084	-.039	.234	.157	.075	.791 (Acceptable)
HB2	-.026	.708	.098	.117	.078	.182	.281	.104	
HB1	.164	.566	.132	.060	.020	.085	.353	.298	
SF2	.212	.031	.752	.149	.140	.105	.278	.175	.895 (Good)
SF3	.236	.072	.731	.214	.108	.097	.236	.181	
SF1	.174	.186	.690	.233	.164	.078	.157	.149	
IQ2	.249	.025	.622	.117	.203	.274	.008	.215	.829 (Good)
IQ3	.167	.079	.575	.128	.227	.217	.061	.318	
IQ1	.228	.116	.561	.134	.269	.137	.045	.223	
HM2	.019	.224	.167	.769	.059	.104	.131	.125	.817 (Good)
HM3	-.028	.170	-.022	.735	.017	.181	.214	.200	
HM1	.188	.113	.286	.725	.085	.052	.084	.108	
PE1	.347	.064	.138	.523	.387	.144	.104	.233	.884 (Good)
PE2	.333	.077	.127	.486	.436	.093	.148	.187	
PE3	.297	.135	.167	.446	.454	.129	.135	.255	
PV2	.115	.146	.177	.047	.771	.125	.215	.151	.826 (Good)
PV1	.095	.108	.105	.102	.765	.103	.233	.085	
PV3	.191	.181	.209	.107	.602	.163	.252	.220	
SQ2	.084	.135	.101	.062	.055	.864	.165	.135	.896 (Good)
SQ3	.045	.094	.096	.137	.107	.853	.161	.112	
SQ1	.067	.057	.073	.067	.090	.853	.141	.130	
SI2	.064	.212	.054	.110	.158	.154	.853	.069	.876 (Good)
SI3	.082	.179	.059	.158	.195	.176	.799	.067	
SI1	.159	.083	.166	.115	.189	.213	.742	.098	
TR2	.173	.129	.161	.157	.120	.156	.098	.804	.820 (Good)
TR3	.012	.045	.090	.118	.105	.140	.134	.797	
TR1	.103	.139	.200	.171	.134	.140	.022	.751	

### C. Gender and Generation Differences

Gender difference between males and females was calculated using T-test and the result was shown on Table VI.

TABLE VI. MEAN DIFFERENCES BETWEEN MALES AND FEMALES

	Levene's Test for Equality of Variances		t	Sig. (2-tailed)	Mean for Males - Mean for Females
	F	Sig.			
A	8.902	.003	4.658	.000	1.041
EDU	1.668	.197	3.942	.000	.209
E	.193	.661	-.685	.494	-.162
D/W	.299	.585	-.726	.468	-.166
M/D	.001	.970	-.569	.570	-.065
ASF	1.179	.278	-2.328	.021	-.16400
AIQ	5.864	.016	-2.449	.015	-.16370
ASQ	.099	.753	-1.508	.132	-.11438
ATR	.196	.659	.896	.371	.06207
AHM	.960	.328	-1.220	.223	-.08662
APE	.006	.937	-1.170	.243	-.08365
AEE	.369	.544	-1.970	.050	-.14132
ASI	.005	.944	.287	.774	.02145
AFC	.018	.892	-.561	.575	-.03896
APV	1.147	.285	-.784	.434	-.05446
AHB	.809	.369	-.404	.686	-.03556
ABI	.120	.729	.473	.637	.03878

Similar to Table VI, Table VII presents generation difference between Z and Y generations.

TABLE VII. MEAN DIFFERENCES BETWEEN Z AND Y GENERATION

	Levene's Test for Equality of Variances		t	Sig. (2-tailed)	Mean for Z - Mean for Y Generations
	F	Sig.			
G	.262	.609	4.233	.000	.249
E	.152	.697	-.942	.347	-.247
D/W	.981	.323	.242	.809	.062
M/D	1.410	.236	-.967	.334	-.123
ASF	.612	.435	1.202	.230	.09474
AIQ	1.949	.164	-1.165	.286	-.01241
ASQ	.190	.663	.468	.640	.03959
ATR	1.829	.177	-1.509	.132	-.11593
AHM	3.202	.074	-2.282	.023	-.17917
APE	1.042	.308	.456	.649	.03633
AEE	.229	.633	.676	.499	.05422
ASI	.469	.494	-2.072	.039	-.17108
AFC	1.014	.315	-1.112	.267	-.08584
APV	.001	.974	-.635	.526	-.04926
AHB	.039	.843	-1.678	.094	-.16355
ABI	2.296	.131	-1.022	.307	-.09311

### D. Correlation Analysis

The graphical representation of correlation among variables presents on Figure 2 and is derived from Table VIII (statistically significant correlation, Table VI (statistically significant difference between males and females) and Table VII (statistically significant difference between Z and Y generations).

From Figure 2, it can be concluded that:

1) There are a positive correlation among variables: Effort Expectancy, Satisfaction, Perceived Information Quality, Perceived Service Quality, Trust, Performance Expectancy, Hedonic Motivation, Social Influence,

Facilitating Conditions, Habit, Price Value, and Behavioral Intention.

TABLE VIII. CORRELATION ANALYSIS OF VARIABLES

		Variables														
	A	E	D/W	M/D	ASF	AIQ	ASQ	ATR	AHM	APE	AEE	ASI	AFC	APV	AHB	ABI
A	1	.066	-.037	.081	-.034	-.037	-.072	.041	.139*	-.033	-.015	.018	.067	.003	.045	.028
E		1	.300**	.115*	.283**	.254**	.126*	.219**	.170**	.213**	.301**	.130*	.293**	.185**	.170**	.213**
D/W			1	.091	.105	.077	.029	.086	.066	.047	.103	.146**	.146**	.122*	.221**	.145**
M/D				1	.064	.105	.023	.064	.239**	.078	.129**	.099	.174**	.141**	.156**	.114*
ASF					1	.610**	.329**	.465**	.421**	.543**	.562**	.415**	.543**	.472**	.298**	.389**
AIQ						1	.367**	.502**	.390**	.523**	.561**	.354**	.532**	.483**	.273**	.357**
ASQ							1	.375**	.301**	.333**	.342**	.414**	.270**	.335**	.342**	.266**
ATR								1	.418**	.483**	.416**	.317**	.401**	.417**	.338**	.380**
AHM									1	.522**	.373**	.385**	.375**	.376**	.388**	.448**
APE										1	.576**	.438**	.554**	.548**	.322**	.479**
AEE											1	.387**	.637**	.488**	.263**	.380**
ASI												1	.392**	.502**	.462**	.448**
AFC													1	.527**	.274**	.422**
APV														1	.362**	.466**
AHB															1	.636**
ABI																1

1) Individuals with high experience have more: easier, satisfy, believe in getting certain information and service quality, trust, believe it help them to attain personal gains, hedonic motivation, influenced by friends and family, believe that their technical infrastructure can support them, habit, acceptable with price value and intention in using e-commerce technology. Individuals with high experience also have high level of duration in day per week and minute per day in using e-commerce technology.

Age, and Education. It means that males are more older and have higher education than females in this study. Furthermore, males are less satisfy and finding more difficulty in using e-commerce technology and hold less information with better quality than females.

5) The Significant difference due to Z and Y generations where found on Hedonic Motivation and Social Influence and not on else. It means that Z generations hold less hedonic motivation and influenced by friends and family in using e-commerce than Y generation.

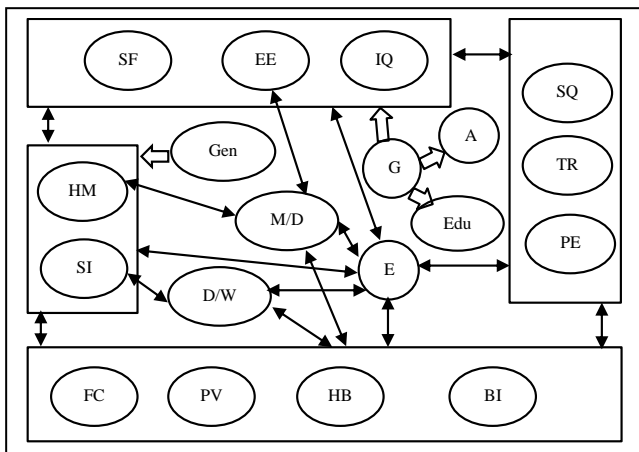

Fig. 2. Graphical Representation of Correlations and Mean Difference of Gender and Generation

2) Individuals with the high level of Social Influence in using e-commerce have high number of day each week in using it.

3) The variables Effort Expectancy, Satisfaction, Perceived Information Quality and Age have significantly difference due to Gender. It means that males and females have difference perception on finding easier in using e-commerce, feeling satisfy, perception on finding certain information, and on age in using e-commerce technology.

4) The Significant difference due to gender are found on Satisfaction, Perceive Ease of Use, Information Quality,

ACKNOWLEDGMENT

I would like to gratefully acknowledge the Ministry of Research, Technology and Higher Education of the Republic of Indonesia, which provide research project including the support from Department of Information Systems, Soegijapranata Catholic University, Indonesia.

REFERENCES

- [1] S. Kemp,. "Special Reports, Digital 2019: Global Internet Use Accelerates," *wearesocial.com*, Jan. 30, 2019. [Online]. Available: <https://wearesocial.com/blog/2019/01/digital-2019-global-internet-use-accelerates>. [Accessed: July. 1, 2019].
- [2] J. Barney, "The Ultimate eCommerce Infographic 2019," *einsteinmarketer.com*, Jan. 3, 2019, [Online]. Available: <https://www.einsteinmarketer.com/e-commerce-infographic-2019/>. [Accessed: July. 1, 2019].
- [3] Asosiasi Penyelenggara Jasa Internet Indonesia, "Laporan Survei: Penetrasi dan Profil Perilaku Pengguna Internet Indonesia," *Asosiasi Penyelenggara Jasa Internet Indonesia – APJII*, May 18, 2019. [Online]. Available: <https://apjii.or.id/survei2018s>. [Accessed: July. 1, 2019].
- [4] B. Harnadi, "An investigation of the adoption of online game technologies in Indonesia," *International Journal of Gaming and Computer-Mediated Simulations*, vol.9, issue 1, pp. 1–27, 2017.
- [5] S. K. Sharma and M. Sharma, "Examining the role of trust and quality dimensions in the actual usage of mobile banking services: An empirical investigation," *International Journal of Information Management*, vol. 44, pp. 65-75, 2019.
- [6] A. M. Baabdullah, A. A. Alalwan, N. P. Rana, H. Kizgin, P. Patil, "Consumer use of mobile banking (M-Banking) in Saudi Arabia: Towards an integrated model," *International Journal of Information Management*, vol. 44, pp. Pages 38-52, 2019.

- [7] M. A. Shareef, A. Baabdullah, S. Dutta, V. Kumar, Y. K. Dwivedi, "Consumer adoption of mobile banking services: An empirical examination of factors according to adoption stages," *Journal of Retailing and Consumer Services*, vol. 43, 2018.
- [8] S. F. Verkijika, "Factors influencing the adoption of mobile commerce applications in Cameroon," *Telematics and Informatics*, Vol. 35, Issue 6, pp. 1665-1674, 2018.
- [9] H. R. Marriott, M. D. Williams, "Exploring consumers perceived risk and trust for mobile shopping: A theoretical framework and empirical study," *Journal of Retailing and Consumer Services*, vol. 42, pp. 133-146, 2018.
- [10] S. Agrebi, J. Jallais, "Explain the intention to use smartphones for mobile shopping," *Journal of Retailing and Consumer Services*, vol. 22, pp. 16-23, 2015.
- [11] A. A. Alalwan, Y. K. Dwivedi, N. P. Rana, "Factors influencing adoption of mobile banking by Jordanian bank customers: Extending UTAUT2 with trust," *International Journal of Information Management*, vol. 37, Issue 3, pp. 99-110, 2017.
- [12] F. M-Leiva, S. C-Climent, F. L-Cabanillas, "Determinants of intention to use the mobile banking apps: An extension of the classic TAM model," *Spanish Journal of Marketing - ESIC*, vol. 21, Issue 1, pp. 25-38, 2017.
- [13] M. N. Masrek, I. S. Mohamed, N. M. Daud, N. Omar, "Technology Trust and Mobile Banking Satisfaction: A Case of Malaysian Consumers," *Procedia - Social and Behavioral Sciences*, vol. 129, pp. 53-58, 2014.
- [14] A. A. Alalwan, Y. K. Dwivedi, N. P. Rana, R. Algharabat, "Examining factors influencing Jordanian customers' intentions and adoption of internet banking: Extending UTAUT2 with risk," *Journal of Retailing and Consumer Services*, vol. 40, pp.125-138, 2018.
- [15] V. Venkatesh, J. Y. L. Thong, & X. Xu, "Extending the Unified Theory of Acceptance and Use of Technology", *MIS Quarterly*, vol. 36, no. 1, pp. 157-178, 2012.
- [16] P. K. Chopdar, N. Korfiatis, VJ. Sivakumar, and M. D. Lytras, "Mobile shopping apps adoption and perceived risks: A cross-country perspective utilizing the Unified Theory of Acceptance and Use of Technology," *Computers in Human Behaviour*, vol. 86, pp. 109-128, 2018.
- [17] W. Boonsiritomachai, K. Pitchayadejanant, "Determinants affecting mobile banking adoption by generation Y based on the Unified Theory of Acceptance and Use of Technology Model modified by the Technology Acceptance Model concept," *Kasetsart Journal of Social Sciences*, 2017.
- [18] A. M. Baabdullah, A. A. Alalwan, N. P. Rana, H. Kizgin, P. Patil, "Consumer use of mobile banking (M-Banking) in Saudi Arabia: Towards an integrated model," *International Journal of Information Management*, vol. 44, pp. 38-52, 2019.
- [19] F. D. Davis, "Perceived Usefulness, Perceived Ease of Use, and User Acceptance of Information Technology," *Management Information Systems Quarterly*, vol. 13, no. 3, pp. 319-340, 1989.
- [20] V. Venkatesh, M. G. Morris, G. B. Davis, and F. D. Davis, "User acceptance of information technology: toward a Unified View," *MIS Quarterly*, vol. 27, no. 3, pp. 425-479, 2003.
- [21] C. Martins, T. Oliveira, A. Popovič, "Understanding the Internet banking adoption: A unified theory of acceptance and use of technology and perceived risk application," *International Journal of Information Management*, vol. 34, Issue 1, pp. 1-13, 2014.
- [22] K. A. Alshare, and Abeer A. Mousa, "The Moderating Effect of Espoused Cultural Dimensions on Consumer's Intention to Use Mobile Payment Devices," *Thirty Fifth International Conference on Information Systems*, Auckland, pp. 1-15, 2014.
- [23] T. Zhou, Y. Lu, B. Wang, "Integrating TTF and UTAUT to explain mobile banking user adoption," *Computers in Human Behavior*, vol. 26, Issue 4, pp. 760-767, 2010.
- [24] B. Hernández, J. Jiménez, and M. J. Martín, "Age, gender and income: Do they really moderate online shopping behaviour?" *Online Information Review*, vol. 35, no. 1, pp. 113-133, 2011.





REPUBLIK INDONESIA  
KEMENTERIAN HUKUM DAN HAK ASASI MANUSIA

# SURAT PENCATATAN CIPTAAN

Dalam rangka perlindungan ciptaan di bidang ilmu pengetahuan, seni dan sastra berdasarkan Undang-Undang Nomor 28 Tahun 2014 tentang Hak Cipta, dengan ini menerangkan:

Nomor dan tanggal permohonan : EC00201951092, 16 Agustus 2019

## Pencipta

Nama : **FX. Hendra Prasetya, ST, MT, Bernadinus Harnadi, Ph.D, , dkk**  
Alamat : Jl. Kepodang Barat IV/C50 Pudak Payung, Semarang, Jawa Tengah, 50265  
Kewarganegaraan : Indonesia

## Pemegang Hak Cipta

Nama : **LPPM Universitas Katolik Soegijapranata**  
Alamat : Jl. Pawiyatan Luhur IV/1, Bendan Dhuwur, Semarang, Jawa Tengah, 50234

Kewarganegaraan : Indonesia

Jenis Ciptaan : **Karya Tulis (Artikel)**

Judul Ciptaan : **The Difference Adoption Of E-Commerce Technology Among Z And Y Generations**

Tanggal dan tempat diumumkan untuk pertama kali di wilayah Indonesia atau di luar wilayah Indonesia : 31 Juli 2019, di Semarang

Jangka waktu perlindungan : Berlaku selama 50 (lima puluh) tahun sejak Ciptaan tersebut pertama kali dilakukan Pengumuman.

Nomor pencatatan : 000150732

adalah benar berdasarkan keterangan yang diberikan oleh Pemohon.

Surat Pencatatan Hak Cipta atau produk Hak terkait ini sesuai dengan Pasal 72 Undang-Undang Nomor 28 Tahun 2014 tentang Hak Cipta.

a.n. MENTERI HUKUM DAN HAK ASASI MANUSIA  
DIREKTUR JENDERAL KEKAYAAN INTELEKTUAL



Dr. Freddy Harris, S.H., LL.M., ACCS.  
NIP. 196611181994031001

## LAMPIRAN PENCIPTA

No	Nama	Alamat
1	FX. Hendra Prasetya, ST, MT	Jl. Kepodang Barat IV/C50 Puduk Payung
2	Bernadinus Harnadi, Ph.D	Jl. Karangroto Blok A RT 03/RW04
3	Albertus Dwi Yoga Widianoro, S.Kom, M.Kom	Griya Sekar Gading Blok C No 8 Gunung Pati



**LAPORAN TAHUN II  
HIBAH PENELITIAN KOMPETITIF  
(PENELITIAN TERAPAN)**

**LEMBAGA PENELITIAN DAN PENGABDIAN KEPADA MASYARAKAT  
SOEGIJAPRANATA CATHOLIC UNIVERSITY**

Jl. Pawiyatan Luhur IV/1 Bendan Duwur Semarang 50234  
Telp. (024) 8441555, 8505003 (hunting) Fax. (024) 8415429 - 8445265  
e-mail: unika@unika.ac.id http://www.unika.ac.id



**LEMBAR PENGESAHAN  
PROPOSAL/LAPORAN KEMAJUAN/LAPORAN AKHIR  
PROGRAM PENELITIAN**

1. Judul Penelitian : Model dan implementasi Industri Kreatif Digital Berbasis Adopsi Teknologi Informasi Generasi Y dan Z
2. Bidang Fokus : Teknologi Informasi
3. Skema : Penelitian Dasar Unggulan Perguruan Tinggi
4. Ketua Tim :
  - a. Nama : Dr. Bernardinus Harnadi, ST.,MT
  - b. Jabatan/Golongan : Lektor Kepala/IV B
  - c. NIDN : 0621056901
  - d. Program Studi : Fakultas Ilmu Komputer
5. Nama Anggota Tim :
  - a. Albertus Dwi Yoga Widiantoro, S.Kom., M.Kom (0605017301)
  - b. FX. Hendra Prasetya, ST.,MT. ( 0615107101)
6. Luaran Yang dihasilkan : Aplikasi Web Dcreative Unika, Jurnal dan Proceeding
7. Sumber Dana : DIKTI
8. Total dana : Rp 144.175.000,00
9. Waktu Pelaksanaan : 12 Maret -22 Desember 2020



Semarang,  
Mengetahui,  
Kepala LPPM

Dr. Berta Sakti Retnawati, SE, M.Si  
NIDN: 0606097302

Ketua Tim Peneliti

Dr. Bernardinus Harnadi, ST.,MT  
NIDN.0630107101

**LEMBAGA PENELITIAN DAN PENGABDIAN KEPADA MASYARAKAT**

Jl. Pawiyatan Luhur IV/1 Bendan Duwur Semarang 50234  
Telp. (024) 8441555, 8505003 (ext. 1461, 1462), Fax. (024) 8445265  
e-mail: lppm@unika.ac.id, lppm.unikasmg@gmail.com  
http://www.unika.ac.id



**SURAT TUGAS**

Nomor : 00760/H.2/ST.LPPM/VII/2020

Kepala Lembaga Penelitian dan Pengabdian Kepada Masyarakat Universitas Katolik Soegijapranata Semarang dengan ini memberi tugas kepada :

- Nama : Dr. Bernardinus Harnadi, ST.,MT (Ketua)  
Albertus Dwi Yoga Widianoro S.Kom, M.Kom (Anggota)  
FX. Hendra Prasetya, S.T, M.T (Anggota)
- Status : Dosen Tetap Universitas Katolik Soegijapranata Semarang
- Tugas : Penelitian Ristek Dikti tahun anggaran 2020 Skim Penelitian Terapan Unggulan Perguruan Tinggi dengan judul "Model dan Implementasi Industri Kreatif Digital Berbasis Adopsi Teknologi Informasi Generasi Y dan Z"
- Waktu : 12 Maret – 22 Desember 2020
- Penyelenggara : Ristek-Dikti
- Lain-lain : Harap melaksanakan tugas dengan sebaik-baiknya dan penuh tanggung jawab serta memberikan laporan setelah selesai melaksanakan tugas.

Demikian surat tugas ini dibuat untuk dapat dipergunakan sebagaimana mestinya.

Semarang, 3 Juli 2020  
Kepala LPPM



*Handwritten signature of Dr. Berta Berti Retnawati*

Dr. Berta Berti Retnawati, MSi  
NPP.058.1. 1998.219



### PROTEKSI ISI LAPORAN AKHIR PENELITIAN

Dilarang menyalin, menyimpan, memperbanyak sebagian atau seluruh isi laporan ini dalam bentuk apapun kecuali oleh peneliti dan pengelola administrasi penelitian

## LAPORAN AKHIR PENELITIAN MULTI TAHUN

ID Proposal: f26072e2-8497-4e5a-afb9-fbdbea77dd8d  
Laporan Akhir Penelitian: tahun ke-2 dari 2 tahun

### 1. IDENTITAS PENELITIAN

#### A. JUDUL PENELITIAN

Model dan implementasi Industri Kreatif Digital Berbasis Adopsi Teknologi Informasi Generasi Y dan Z

#### B. BIDANG, TEMA, TOPIK, DAN RUMPUN BIDANG ILMU

Bidang Fokus RIRN / Bidang Unggulan Perguruan Tinggi	Tema	Topik (jika ada)	Rumpun Bidang Ilmu
Pengembangan Industri Kreatif dan UMKM	-	Pengembangan Potensi Sumber Daya Lokal Berbasis Industri Kreatif	Sistem Informasi

#### C. KATEGORI, SKEMA, SBK, TARGET TKT DAN LAMA PENELITIAN

Kategori (Kompetitif Nasional/ Desentralisasi/ Penugasan)	Skema Penelitian	Strata (Dasar/ Terapan/ Pengembangan)	SBK (Dasar, Terapan, Pengembangan)	Target Akhir TKT	Lama Penelitian (Tahun)
Penelitian Desentralisasi	Penelitian Terapan Unggulan Perguruan Tinggi	SBK Riset Terapan	SBK Riset Terapan	6	2

### 2. IDENTITAS PENGUSUL

Nama, Peran	Perguruan Tinggi/ Institusi	Program Studi/ Bagian	Bidang Tugas	ID Sinta	H-Index
BERNADINUS HARNADI Ketua Pengusul	Universitas Katolik Soegijapranata	Sistem Informasi		5976331	1
ALBERTUS DWI YOGA WIDIANTORO S.Kom, M.Kom Anggota Pengusul 1	Universitas Katolik Soegijapranata	Sistem Informasi		9803	1
FX HENDRA PRASETYA S.T, M.T	Universitas Katolik Soegijapranata	Sistem Informasi		6131369	0

Anggota Pengusul 2					
-----------------------	--	--	--	--	--

### 3. MITRA KERJASAMA PENELITIAN (JIKA ADA)

Pelaksanaan penelitian dapat melibatkan mitra kerjasama, yaitu mitra kerjasama dalam melaksanakan penelitian, mitra sebagai calon pengguna hasil penelitian, atau mitra investor

Mitra	Nama Mitra
Mitra Calon Pengguna	Andre Setiawan

### 4. LUARAN DAN TARGET CAPAIAN

#### Luaran Wajib

Tahun Luaran	Jenis Luaran	Status target capaian ( <i>accepted, published, terdaftar atau granted, atau status lainnya</i> )	Keterangan ( <i>url dan nama jurnal, penerbit, url paten, keterangan sejenis lainnya</i> )
2	Dokumentasi hasil uji coba produk	Ada	

#### Luaran Tambahan

Tahun Luaran	Jenis Luaran	Status target capaian ( <i>accepted, published, terdaftar atau granted, atau status lainnya</i> )	Keterangan ( <i>url dan nama jurnal, penerbit, url paten, keterangan sejenis lainnya</i> )
2	Publikasi Ilmiah Jurnal Internasional	submitted	International Journal on Advanced Science, Engineering and Information Technology, Publisher: INSIGHT - Indonesian Society for Knowledge and Human Development
2	Prosiding dalam pertemuan ilmiah Internasional	sudah terbit/sudah dilaksanakan	International Conference IEEE
2	Prosiding dalam pertemuan ilmiah Nasional	sudah terbit/sudah dilaksanakan	Seminar Nasional Aplikasi Teknologi Informasi (SNATI)

### 5. ANGGARAN

Rencana anggaran biaya penelitian mengacu pada PMK yang berlaku dengan besaran minimum dan maksimum sebagaimana diatur pada buku Panduan Penelitian dan Pengabdian kepada Masyarakat Edisi 12.

**Total RAB 2 Tahun Rp. 144,175,000**

**Tahun 1 Total Rp. 0**

**Tahun 2 Total Rp. 144,175,000**

Jenis Pembelanjaan	Item	Satuan	Vol.	Biaya Satuan	Total
Analisis Data	Biaya analisis sampel	Unit	2	4,150,000	8,300,000
Analisis Data	Transport Lokal	OK (kali)	2	2,650,000	5,300,000
Analisis Data	Biaya konsumsi rapat	OH	2	4,612,500	9,225,000
Bahan	ATK	Paket	1	3,400,000	3,400,000

Jenis Pembelanjaan	Item	Satuan	Vol.	Biaya Satuan	Total
Bahan	Bahan Penelitian (Habis Pakai)	Unit	2	10,100,000	20,200,000
Pelaporan, Luaran Wajib, dan Luaran Tambahan	Biaya seminar nasional	Paket	1	3,000,000	3,000,000
Pelaporan, Luaran Wajib, dan Luaran Tambahan	Publikasi artikel di Jurnal Internasional	Paket	1	50,000,000	50,000,000
Pelaporan, Luaran Wajib, dan Luaran Tambahan	Biaya seminar internasional	Paket	3	3,000,000	9,000,000
Pengumpulan Data	FGD persiapan penelitian	Paket	2	5,000,000	10,000,000
Pengumpulan Data	HR Pembantu Peneliti	OJ	360	25,000	9,000,000
Sewa Peralatan	Peralatan penelitian	Unit	1	16,750,000	16,750,000

## 6. HASIL PENELITIAN

**A. RINGKASAN:** Tuliskan secara ringkas latar belakang penelitian, tujuan dan tahapan metode penelitian, luaran yang ditargetkan, serta uraian TKT penelitian.

Industri kreatif digital terbukti mampu memberikan sumbangan yang signifikan pada peningkatan pendapatan nasional, penyediaan lapangan pekerjaan, dan kenaikan nilai ekspor Indonesia. Dengan besarnya pengguna internet dan ponsel pintar serta pesatnya pertumbuhan transaksi e-commerce di kalangan generasi Y dan Z maka Indonesia menjadi pasar potensial bagi industri kreatif digital. Investigasi mendalam ke dalam kedua generasi ini dalam bentuk pengembangan model adopsi teknologi informasi akan memberikan kontribusi yang berharga dalam pengembangan model dan implementasi industri kreatif digital di Indonesia.

Tahun 2020 Indonesia mengalami dampak pandemi Covid-19. Pandemi Covid-19 berdampak buruk pada berbagai aspek di bidang kesehatan, sosial, dan ekonomi. Namun demikian, efek pandemi juga berdampak pada percepatan adopsi teknologi informasi di bidang Kesehatan, Pendidikan, dan Perdagangan karena keterbatasan interaksi fisik antar manusia. Hal ini juga mempengaruhi kelangsungan usaha UMKM di Indonesia. Sebagian besar UMKM belum memiliki kesiapan SDM menghadapi pandemi ini. Sementara itu adopsi teknologi e-commerce mengalami peningkatan yang luar biasa dengan bertambahnya konsumen yang bertransaksi secara online. Di tengah euforia meningkatnya jumlah konsumen dan transaksi online, muncul pertanyaan apakah pelaku industri kreatif dan UMKM siap memanfaatkan momentum ini.

Berdasarkan latar belakang ini, penelitian tahun kedua "Model dan implementasi Industri Kreatif Digital Berbasis Adopsi Teknologi Informasi Generasi Y dan Z" disinergikan dengan pemberdayaan UMKM yang berdampak pandemi. Sinergi ini memiliki alasan bahwa model dan implementasi Industri Kreatif Digital yang dikembangkan pada penelitian ini berupa rancang bangun website e-marketplace bagi industri kreatif digital juga dapat dimanfaatkan oleh UMKM atau dapat diistilahkan "mendigitalisasi UMKM".

Penelitian tahun ke dua ini bertujuan untuk mengembangkan aplikasi e-marketplace bagi industri kreatif digital dan UMKM berbasis web dengan menggunakan manajemen proyek waterfall dengan enam tahapan analisis secara berjenjang seperti berikut: spesifikasi kebutuhan, desain, pengembangan, pengujian, dan implementasi. Langkah pertama kegiatan dilakukan dengan cara menemukan spesifikasi kebutuhan untuk pengembangan website dari penelitian tahun 1 tentang Adopsi Teknologi E-Commerce. Ada beberapa variabel perilaku dan individu dan hubungannya yang dianalisis untuk mendapatkan spesifikasi kebutuhan aplikasi. Langkah berikutnya, berdasarkan spesifikasi, aplikasi



dirancang dengan menggunakan diagram UML dan dibangun dengan menggunakan alat bantu pemrograman website. Langkah pengujian dan integrasi dilakukan dalam tiga tahap, yaitu dua kali pengujian di sisi penjual dan satu pengujian di sisi pembeli. Penyempurnaan aplikasi diturunkan dari tahap pengujian. Versi Beta dari aplikasi telah diselesaikan dengan menerapkan tahap-tahap tersebut dan siap diimplementasikan dan disempurnakan sebagai e-marketplace industri kreatif digital dan UMKM berbasis web.

Secara alur kegiatan, penelitian tahun kedua dimulai dengan mengkaji teori yang relevan yang dapat digunakan untuk merancang instrument penelitian dan digunakan bagi perancangan dan pengujian website e-marketplace. Pengujian model dilakukan melalui FGD dan hasilnya digunakan untuk perancangan dan implementasi website dan aplikasi android. Hasilnya diujicobakan ke para respondent yang berperan sebagai penjual dan pembeli dalam sistem e-marketplace. Hasil pengembangan website juga direview kembali melalui FGD dengan para pakar pengembang web dan pelaku industri kreatif/UMKM. Setelah penyempurnaan dirasa cukup maka dilakukan workshop pemanfaatan website dan aplikasi e-marketplace. Luaran wajib penelitian tahun kedua ini berupa dokumen hasil uji coba produk dalam hal ini uji coba website e-marketplace dcreatifunika.id. Sedangkan luaran tambahan pada tahun kedua ini dipublikasikan dalam konferensi internasional ICIC-Aptikom 2020 dengan status accepted, seminar nasional 3rd EIconCIT 2021 dengan status submitted, dan jurnal internasional dengan status submitted. Dari segi tingkat kesiapan teknologi penelitian tahun kedua berada pada TKT 6.

Penelitian ini memberikan kontribusi bagi pengembangan industri kreatif dan UMKM di Indonesia melalui pengembangan website e-marketplace. Demikian juga bagi mereka yang berkepentingan terhadap hasil penelitian behavioral pada generasi Y dan Z terutama para pelaku pasar yang menjadikan kedua generasi tersebut sebagai pasar potensial dan para pengambil keputusan di dalam pengembangan dan implementasi industri kreatif digital dan UMKM di Indonesia.

**B. KATA KUNCI:** Tuliskan maksimal 5 kata kunci.

e-marketplace, industri kreatif digital, UMKM, website

Pengisian poin C sampai dengan poin H mengikuti template berikut dan tidak dibatasi jumlah kata atau halaman namun disarankan ringkas mungkin. Dilarang menghapus/memodifikasi template ataupun menghapus penjelasan di setiap poin.

**C. HASIL PELAKSANAAN PENELITIAN:** Tuliskan secara ringkas hasil pelaksanaan penelitian yang telah dicapai sesuai tahun pelaksanaan penelitian. Penyajian dapat berupa data, hasil analisis, dan capaian luaran (wajib dan atau tambahan). Seluruh hasil atau capaian yang dilaporkan harus berkaitan dengan tahapan pelaksanaan penelitian sebagaimana direncanakan pada proposal. Penyajian data dapat berupa gambar, tabel, grafik, dan sejenisnya, serta analisis didukung dengan sumber pustaka primer yang relevan dan terkini.

Pengisian poin C sampai dengan poin H mengikuti template berikut dan tidak dibatasi jumlah kata atau halaman namun disarankan ringkas mungkin. Dilarang menghapus/memodifikasi template ataupun menghapus penjelasan di setiap poin.

**C. HASIL PELAKSANAAN PENELITIAN:** Tuliskan secara ringkas hasil pelaksanaan penelitian yang telah dicapai sesuai tahun pelaksanaan penelitian. Penyajian meliputi data, hasil analisis, dan capaian luaran (wajib dan atau tambahan). Seluruh hasil atau capaian yang dilaporkan harus berkaitan dengan tahapan pelaksanaan penelitian sebagaimana direncanakan pada proposal. Penyajian data dapat berupa gambar, tabel, grafik, dan sejenisnya, serta analisis didukung dengan sumber pustaka primer yang relevan dan terkini.

### **Tahapan Hasil Pelaksanaan Penelitian:**

#### **I. Pengkajian Teori yang Relevan**

Pengkajian Teori yang Relevan dilakukan dengan mereview literature terkait dengan perancangan dan pembuatan website E-Commerce yang baik. Dari review literature yang pertama, Novianty (2017) menyoroti faktor tampilan web, desain web yang responsive, dan fungsionalitas web. Menurut Novianty, “tampilan web” seperti header, footer, gambar maupun font teks merupakan hal yang berpengaruh pada kenyamanan responden saat mengakses web melalui perangkat mobile. Berikutnya “desain web yang responsive” mempengaruhi faktor kenyamanan responden dalam hal membaca teks, menu maupun gambar. “Fungsionalitas dari website” yang sulit diakses melalui perangkat mobile mempengaruhi faktor kenyamanan pengguna.

Review literature kedua, Anandhita et al. (2014) mengulas mengenai Kemudahan mengontrol navigasi. Menurut Anandhita “Kemudahan mengontrol navigasi” dapat diartikan sebagai tersedianya akses navigasi yang jelas dan lengkap dan merupakan hal yang penting dalam mendesain web E-Commerce untuk memanjakan pengunjung (Anandhita et al 2014).

Dalam literature ketiga, Bruner and Kumar (2000) mengulas “Performa Web” dalam konteks Web e-commerce. Menurut Bruner and Kumar Performa web sangat diperlukan dalam membangun Web E-Commerce menurut (Bruner and Kumar, 2000).

Berdasar dari pengkajian teori tersebut, maka diambil faktor-faktor yang akan digunakan untuk Perancangan Website dan menyusun instrumen penelitian. Berikut instrumen yang akan dipergunakan yang terdiri dari faktor-faktor:

- Tampilan Web
- Desain Web yang Responsive
- Fungsionalitas Web
- Navigasi Web
- Performa Web

Pustaka yang dipergunakan:

Novianty, C., 2017, “Review Konsep Responsive Design dengan Framework Materialize pada Website“, Jurnal Nasional Informatika dan Teknologi Jaringan, vol.2, no 1.

Anandhita, R. Z., Kertahadi, Suyadi, I., 2014, “Analisis Atas Desain Website Ecommerce ZGS Game Shop”, Jurnal Administrasi Bisnis, vol.9, No.1.

Bruner, G.C., Kumar, A., 2000, “Commercials and Advertising Hierarchy-of-Effects”, Web Journal of Advertising Research, Januari-April, 2000.

Parasuraman A., 2000, “Technology Readiness Index (Tri): A Multiple-Item Scale to Measure Readiness to Embrace New Technologies”. Journal of Service Research. 2000;2(4):307-320. doi:10.1177/109467050024001

#### **II. Penyusunan Instrumen Penelitian**

Instrumen Penelitian merupakan instrumen untuk rencana perancangan dan pengujian website. Pengujian website dilakukan dengan memperhatikan faktor-faktor yang dapat digunakan untuk penilaian.

Berdasarkan “Kegiatan-1 Pengkajian Teori yang Relevan” didapatkan rencana faktor yang akan dipergunakan untuk pengujian website sebagai berikut:

- Tampilan Web
- Desain Responsive
- Fungsionalitas Web
- Navigasi Web
- Performa Web

Dalam pengujian website, respondent yang terlibat dalam pengujian perlu untuk diukur tingkat kesiapan mereka dalam mengangani sistem berbasis teknologi dalam hal ini website, dengan menggunakan instrumen pengukuran Technology Readines Index (TRI) yang dikembangkan oleh Parasuraman (2000). TRI memiliki empat dimensi yang terdiri dari:

- optimisme (optimism)
- inovasi (innovativeness)
- ketidaknyamanan (discomfort)
- ketidakamanan (insecurity)

### III. Pengujian Model Industri Kreatif Digital

Pengkajian Teori yang Relevan dilakukan dengan melakukan Analisis terhadap model dan pengujiannya yang dihasilkan pada penelitian “Adopsi Teknologi E-Commerce” di tahun pertama (*The Difference Adoption of E-Commerce Technology among Z and Y Generations*). Hasil penelitian memunculkan data sebagai berikut:

1. Individu pengguna sistem E-Commerce yang memiliki pengalaman lebih tinggi, mereka akan lebih: merasa mudah dalam menggunakan sistem (*Effort Expectancy*); puas dengan sistem (*Satisfaction*); yakin akan mendapatkan informasi dan kualitas layanan yang diinginkan (*Perceived Information Quality*); percaya terhadap sistem (*Trust*); yakin bahwa sistem akan membawa pada keuntungan pribadi (*Performance Expectancy*); termotivasi untuk terhibur dalam menggunakan sistem (*Hedonic Motivation*); dipengaruhi oleh teman dan keluarga dalam menggunakan sistem (*Social Influence*); percaya bahwa infrastruktur teknis mereka dapat mendukung mereka (*Facilitating Condition*); merasa terbiasa dengan sistem (*Habit*); dapat menerima nilai harga dalam penggunaan sistem (*Price Value*); dan lebih berniat untuk terus menggunakan sistem e-commerce (*Behavioral Intention*). Individu dengan pengalaman lebih tinggi juga memiliki durasi yang tinggi dalam penggunaan sistem e-commerce dalam sehari per minggu dan menit per hari.
2. Individu pengguna dengan tingkat terpengaruh dari ajakan lingkungan sosial (*Social Influence*) yang tinggi dalam menggunakan e-commerce memiliki jumlah hari yang tinggi setiap minggunya dalam menggunakan sistem.
3. Variabel *Effort Expectancy*, *Satisfaction*, *Perceived Information Quality*, Usia, dan Pendidikan dalam konteks penggunaan e-commerce memiliki perbedaan yang signifikan karena Gender. Artinya laki-laki dan perempuan memiliki perbedaan dalam: persepsi tentang kemudahan dalam menggunakan e-commerce, merasa puas, keyakinan akan mendapatkan informasi dan kualitas layanan yang diinginkan, dan usia.
4. Perbedaan yang signifikan karena gender memiliki arti: laki-laki merasa kurang puas, merasa lebih kesulitan dalam menggunakan e-commerce, dan memiliki lebih sedikit keyakinan akan mendapatkan informasi dan kualitas layanan yang diinginkan dibanding perempuan.
5. Perbedaan signifikan karena perbedaan usia/generasi (Z dan Y) ditemukan pada Motivasi Hedonis (*Hedonic Motivation*) dan Pengaruh Sosial (*Social Influence*). Artinya generasi Z kurang memiliki motivasi hedonis (*Hedonic Motivation*) dan lebih dipengaruhi oleh teman atau keluarga dalam menggunakan e-commerce dibandingkan generasi Y.
6. Berdasarkan analisis kausal efek dari model, faktor Kebiasaan dalam menggunakan E-Commerce (*Habit*) memiliki pengaruh positif, besar, dan signifikan secara statistik terhadap keinginan untuk terus menggunakan E-Commerce (*Behavioral Intention*).

Berdasarkan Analisis terhadap model dapat disimpulkan bahwa:

1. Pengalaman dalam menggunakan platform e-commerce merupakan variabel terpenting. Orang yang lebih berpengalaman dalam menggunakan platform e-commerce, akan merasa lebih mudah dalam menggunakan, lebih merasa puas, lebih yakin untuk mendapatkan informasi dan kualitas layanan tertentu, lebih percaya, lebih yakin bahwa platform e-commerce akan membantu mereka untuk mencapai keuntungan pribadi, lebih hedonis, lebih dipengaruhi oleh teman dan keluarga, lebih percaya bahwa infrastruktur teknis yang mereka miliki dapat mendukung mereka dalam menggunakan e-commerce, lebih terbiasa, lebih menerima nilai harga dari penggunaan e-commerce, dan lebih menerima platform e-commerce kedepannya.
2. Pengaruh sosial dalam penggunaan memiliki hubungan yang positif dengan tingginya jumlah hari setiap minggunya dalam menggunakan platform e-commerce.
3. Laki-laki dan perempuan memiliki perbedaan persepsi dalam menggunakan platform e-commerce. Laki-laki lebih merasa kurang puas dan menemukan lebih banyak kesulitan serta merasa kurang yakin

- akan mendapatkan informasi dan kualitas layanan yang diinginkan daripada perempuan dalam menggunakan platform e-commerce.
4. Generasi Z kurang memiliki motivasi hedonis dan dipengaruhi oleh teman dan keluarga dalam menggunakan platform e-commerce dibandingkan generasi Y.
  5. Kebiasaan dalam menggunakan platform e-commerce berpengaruh langsung pada penerimaan mereka terhadapnya.

#### **IV. FGD Analisis Pengujian Model**

FGD Analisis Pengujian Model dengan perwakilan geerasi Y dan Z dilakukan dengan metode konfirmasi terhadap hasil analisis model. Perwakilan generasi Z oleh 3 siswa SLTA dari Semarang dan Ungaran dan 3 mahasiswa perguruan tinggi di Semarang, Surabaya dan Bandung.

5 Opsi hasil analisis Pengujian model dikonfirmasi langsung ke perwakilan generasi Y dan Z dan menghasilkan diskusi berikut:

1. Tentang pengalaman dalam menggunakan platform e-commerce:
  - a. Baik perwakilan generasi Z maupun Y membenarkan statement bahwa pengalaman merupakan faktor yang penting dalam mempengaruhi persepsi-persepsi yang dirasakan oleh mereka.
  - b. Yang pertama adalah faktor pengalaman ini sangat terkait dengan faktor kebiasaan dalam mereka menggunakan platform e-commerce. Semakin lama mereka menggunakan maka mereka akan semakin terbiasa.
  - c. Dengan meningkatnya pengalaman mereka merasakan bahwa sistem e-commerce terasa lebih mudah, mereka merasa lebih enjoy, lebih mempercayai sistemnya, semakin lama semakin lebih merasakan manfaat dan tidak mengalami hambatan dalam mendapatkan informasi dan layanan. Mereka juga mendapati kenyataan bahwa perangkat yang mereka pakai ternyata support thd pemakainya sistem e-commerce.
  - d. Dalam lingkungan pergaulan dengan teman dan keluarga, mereka juga semakin mendapatkan supporting untuk terus menggunakan platform e-commerce, dan teman dan keluarga selalu bersedia memberikan dukungan jika mereka mengalami kesulitan dalam menggunakan.
2. Dalam hal perbedaan gender, dari hasil diskusi terungkap bahwa perwakilan cewek lebih sering menggunakan platform e-commerce dibanding yang cowok. Dari hasil diskusi cowok ternyata lebih sering mengalami masalah dalam menggunakan platform e-commerce.
3. Dalam hal perbedaan generasi terungkap bahwa generasi Y merasa lebih fun dalam menggunakan platform e-commerce dibanding generasi Z. Pada awalnya generasi Z biasa bertanya dengan teman dan keluarga dalam menggunakan platform e-commerce, tetapi akhirnya menjadi terbiasa.
4. Kedua generasi sepakat bahwa faktor kebiasaan dalam menggunakan mempengaruhi keinginan mereka untuk terus menggunakan platform e-commerce.

#### **V. Pengembangan Website Industri Kreatif**

Pengembangan Website Industri Kreatif diwujudkan dengan tahapan perancangan dan pembuatan website E-Marketplace dcreatifunika.id. Berdasar analisis pengujian model tahun I, disepakati untuk merancang website E-Marketplace dengan konsep “memberikan pengalaman yang menyenangkan dalam menggunakan dan rancangan yang cerah untuk anak muda”

##### **1. Tahap Perancangan**

###### **A. Perancangan Use Case Diagram**

Use Case Diagram dikembangkan pada tahap awal pengembangan dan orang sering menerapkan pemodelan use case dengan tujuan: menentukan konteks sistem, mendapatkan/menangkap persyaratan sistem, melakukan validasi arsitektur sistem, dikembangkan oleh analis untuk menetapkan aktivitas sistem.

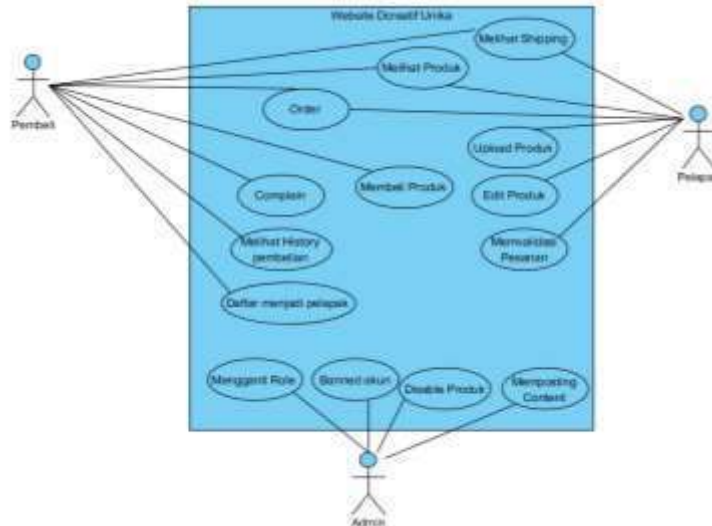

Gambar 1. Use Case Diagram

Dalam sistem e-commerce dcreatifunika.id ini actor yang terlibat adalah pembeli, pelapak, dan administrator sistem. Pembeli melakukan aktivitas melihat shopping, melihat produk, membeli produk, complain, melihat histori, mendaftar menjadi pelapak. Pelapak melakukan aktivitas melihat shopping, melihat produk, upload produk, edit produk, membalidasi pesanan. Sementara admin (administrator sistem) melakukan penggantian role, banned akun, disable produk, memposting konten, melakukan klasifikasi produk.

**B. Perancangan ERD Diagram**

Database Utama E-Commerce dcreatifunika.id terdiri dari beberapa tabel yaitu: Kategori, Produk, Order Detail, Order, Nota, Pembayaran, Shopping, Toko, User, Province, dan City seperti yang terlihat pada Gambar. Proses normalisasi telah dilakukan, sehingga tabel-tabel yang dibangun menjadi database lebih mudah dalam: Pengelompokan Data, Mencegah Data Ganda, Memudahkan Pengelolaan Data Perusahaan, Menjaga Kualitas Data, Meningkatkan Kinerja Aplikasi, Menjaga Kerahasiaan Data, dan Memudahkan Berbagi Data.

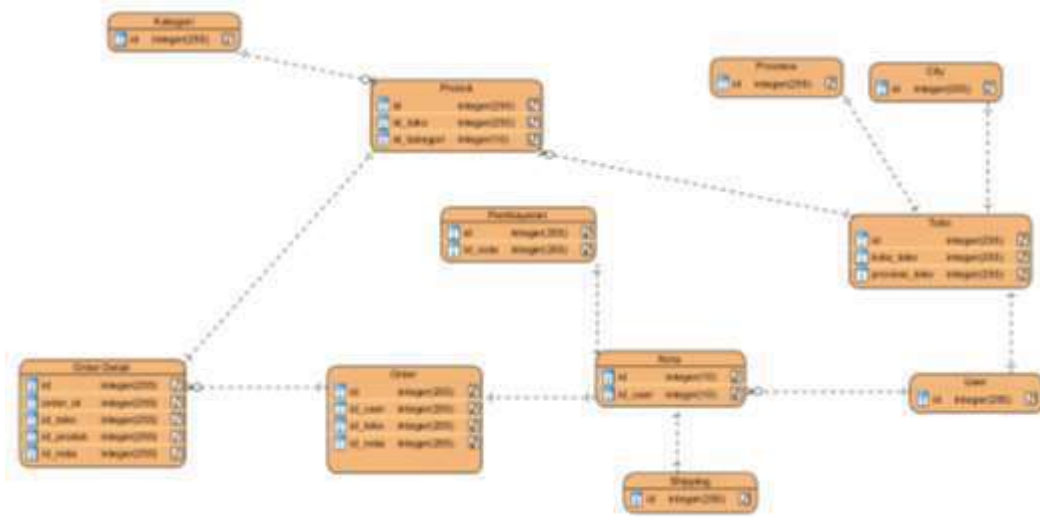

Gambar 2. ERD Diagram

**2. Tahap Pembuatan**

**A. Main page**

Tampilan utama menampilkan produk-produk yang telah dimasukkan oleh pelapak. Tampilan ini dapat dilihat tidak perlu melakukan registrasi. Didalam tampilan depan ini dapat melihat kategori produk, melakukan sign-up dan melakukan sign-in.

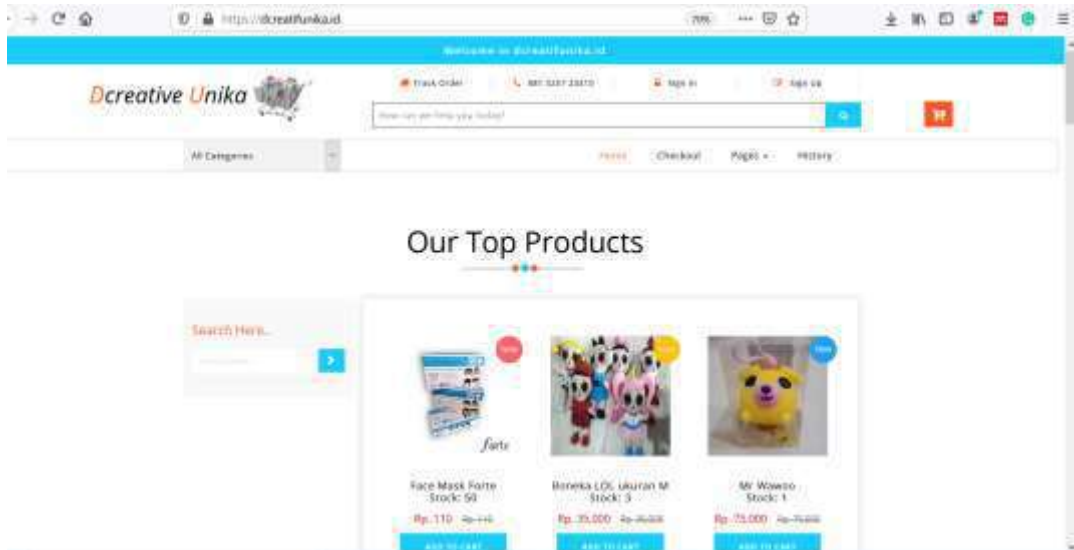

Gambar 3. Main Page

### Sign-up Page

Pembeli dan pelapak dapat melakukan sign-up dengan cara melakukan klik sign-up dan mengisi form berikut

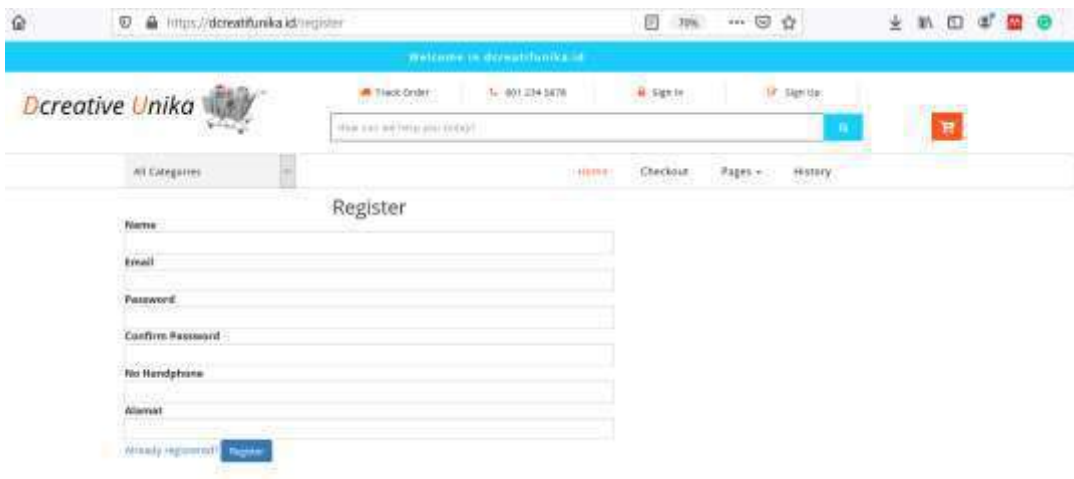

Gambar 4. Sign-up Page

Semua text area wajib diisi, jika terdapat ada text area yang tidak diisi maka tidak dapat melakukan registrasi.

### Sign-in Page

Apabila sudah melakukan registrasi, maka user dapat melakukan sign-in menggunakan user email yang telah didaftarkan.

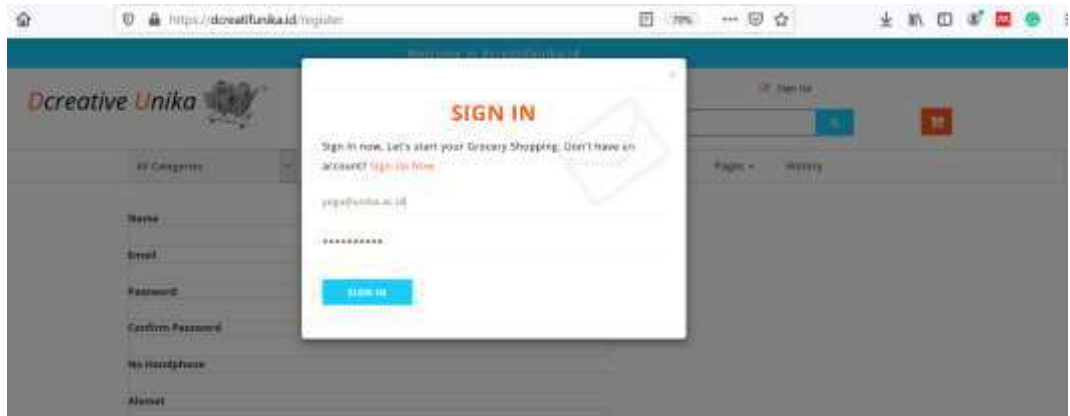

Gambar 5 . Sign-in Page

## Dashboard Page

Setelah login maka user melakukan pembelian, dengan melakukan klik button add to chart disetiap produk.

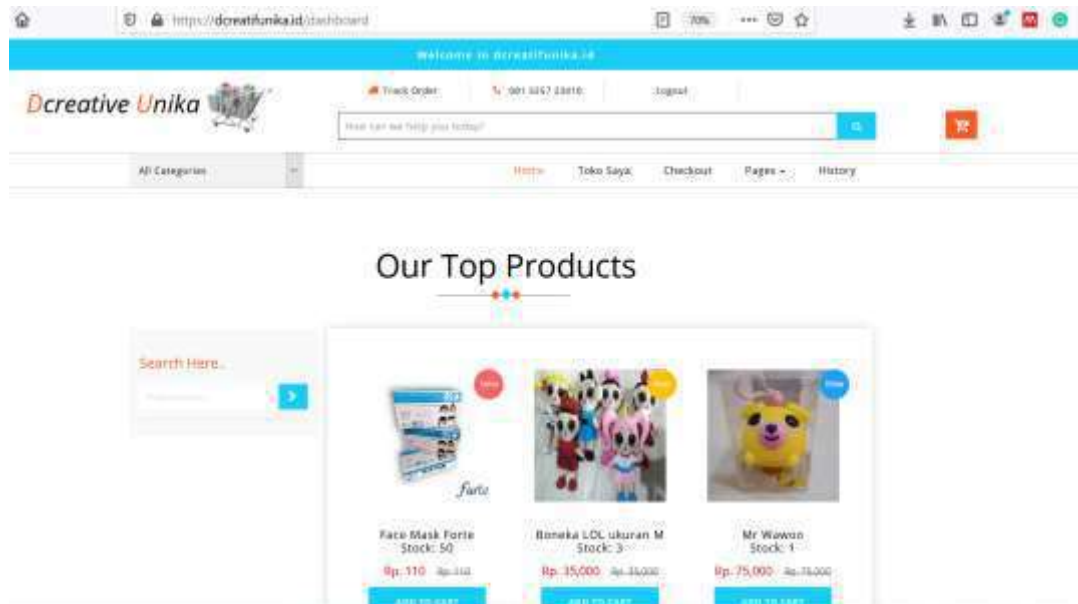

Gambar 6. Dashboard Page

## B. Buyer Page

### Add to Chart

Setelah melakukan add to chart maka pembeli dapat memasukkan jumlah yang akan dibeli seperti terlihat pada gambar dibawah ini. Setelah memasukkan jumlah pembelian, lalu menekan tombol add to chart untuk Kembali ke menu/tampilan awal.

## Detail Produk



Gambar 7. Add to Chart Page

## Check out Page

Terlihat tampilan checkout seperti pada gambar dibawah ini.

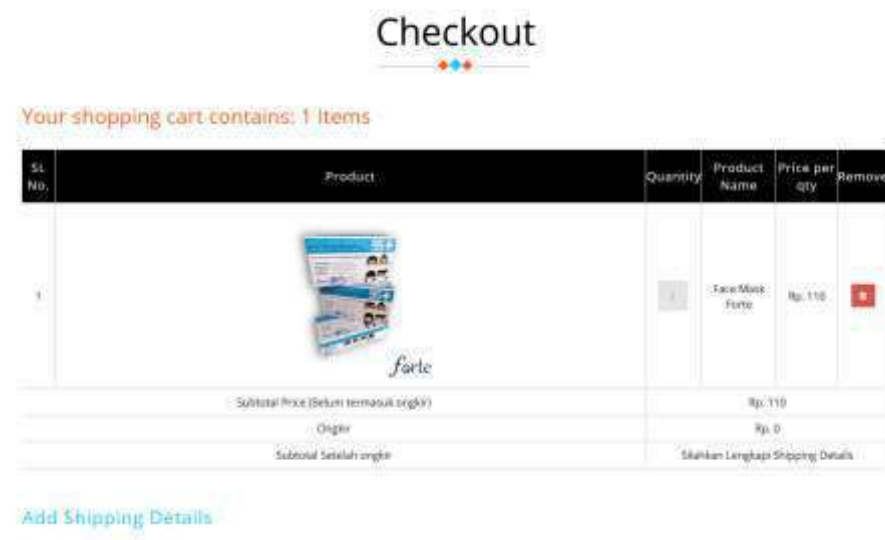

Gambar 8. Check Out Page

## Add Shipping Detail

Menginput data pengiriman



Add Shipping Details

Full Name

Mobile Number

Postcode

Pilih Provinsi

Pilih Kota

Rincian

Street Address

Email Address

Notes about your order, e.g. special notes for delivery.

Checkout Lanjutkan Belanja

Gambar 8. Add Shipping Detail Page

### C. Seller Page

#### Registering Online Shop

Mendaftarkan toko dapat dilakukan jika telah melakukan registrasi dan login. Setelah login maka akan terlihat seperti pada gambar dibawah ini. Gambar yang digaris bawah merah akan muncul.

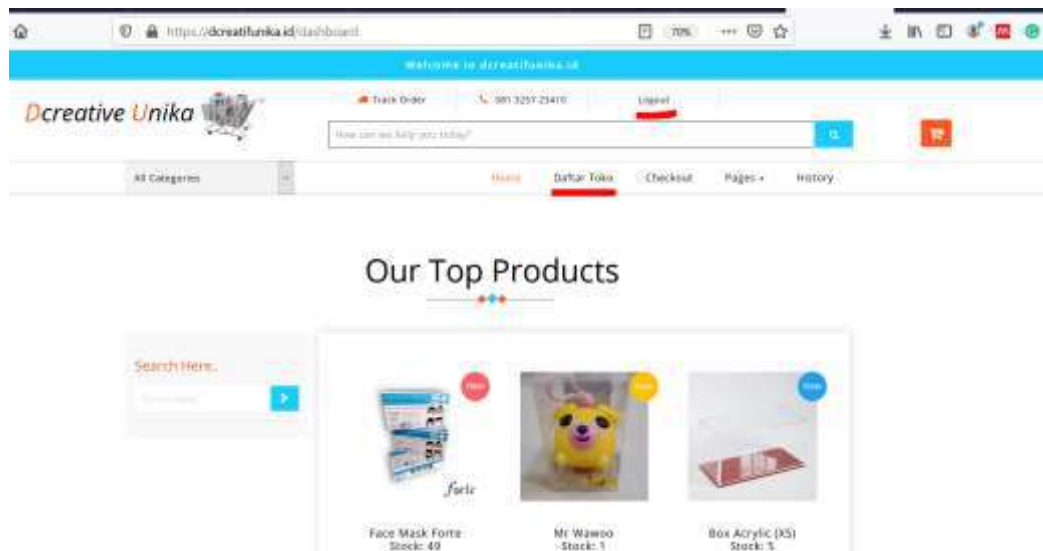

Gambar 9. Register Page

Untuk Mendaftarkan toko lakukan Klik daftar toko, dan akan diminta untuk mengisi form seperti dibawah ini:

## VI. Publikasi Konferens Internasional

Publikasi konferensi Internasional merupakan Luaran Tambahan Penelitian telah terlaksana dan dipresentasikan tetapi belum dipublish oleh publisher IEEE Explor. Paper dan Sertifikat telah diupload dalam sistem Simlibtabmas

Nama Konfernce:

ICIC Aptikom 2020

Judul paper:

*Investigating the Impact of System and Service Qualities on Customer Loyalty in Acceptance of EMarketplace*

Penulis:

FX. Hendra Prasetya, Bernardinus Harnadi, Albertus Dwiyoaga Widianoro, Achmad Nizar Hidayanto, dan Agus Cahyo Nugroho.

Pelaksanaan Conference:

3 – 4 November 2020

Lokasi: Gorontalo, Indonesia

Hasil penelitian yang ditulis dalam paper:

*Investigating the Impact of System and Service Qualities on Customer Loyalty in Acceptance of EMarketplace*

**Abstract**—This paper aims to investigate the influence of System and Service Quality on Customer Loyalty in their acceptance of e-marketplaces. The e-marketplaces are Tokopedia, Bukalapak, Lazada, Sopheer, and others. Several variables from previous related studies on expectation–confirmation model (ECM) and TAM are employed on proposed model to explore the customers satisfaction and their impact on the acceptance of the e-marketplace. The model expresses the effect of System Quality, Service Quality on Confirmation and Satisfaction; Confirmation on Perceived Usefulness and Perceived Ease of Use; Perceived ease of use on Perceived Usefulness; Perceived Usefulness, and Confirmation on Satisfaction; and Perceived Usefulness and Satisfaction on Continuance Intension to use. The model was examined using 210 respondent data and Correlation Analysis was done after the validity and realibility check to reveal the correlation of variables. The analysis of causal effects of variables are tested using Structural Equation Modelling (SEM) using Partial Least Square (PLS). The result reveals that the Satisfaction of customer of e-marketplace platforms were more affected by System Quality, Service Quality and Confirmation than Perceived Usefulness. Whereas, the continue intention to use e-marketplace platform was determined by Perceived Usefulness and Satisfaction. The results have contribution on e-marketplace players and developers who have concern on customer loyalty to attract their continue intention in using the platform.

**Keywords**—adoption, e-marketplace, system quality, service quality, satisfaction

### I. INTRODUCTION

The digital era is moving very fast, especially driven during the Covid-19 pandemic where people are advised to live or work at home, to be used to do all digital-based activities carried out at home. It provides opportunities and challenges The scale of opportunity for businesses has changed, transactions and communication are no longer through traditional channels (physical encounters) but through e-commerce technology.

In today's dynamic movement, it presents opportunities and challenges for decision makers. Increased opportunities for digital businesses have increased, this increase has reached up to 10 or even 20 times that of traditional channels. Even individuals can expand markets from all over the world. Digital marketing provides powerful tools for creating audience engagement, identifying customers, increasing sales, and increasing efficiency and productivity in a variety of areas. To win the competition, companies must position themselves at the forefront of technology, be innovative in making attractive products, consider price and place, and use digital-based commercial platforms [1].

E-commerce platforms allow customers to sort and categorize information and even access opinions from online customer reviews and ratings to improve the shopping process and increase the number of choices available. On the other hand, decreased customer satisfaction can result mainly due to lack of security, relevant privacy, timely human contact [2].

Evidently, the Internet has produced fundamental changes in retail practices, created shifts in both consumer and business behavior, the positive relationship between e-customer satisfaction and consumer shopping at e-commerce retailers has been proven. Namely, the higher the e-customer satisfaction in this area, the more consumers are [3].

System quality is the user's perception of stability, acceptable response, and ease of use. It has been shown that an increase in perceived system quality is related to an increase in perceived usefulness, as well as an increase in user satisfaction with the system. Higher perceived system quality has a stronger effect on perceived usefulness and user satisfaction, leading to a positive influence on system adoption [4].

E-commerce today is part of the community because it can meet people's expectations. E-commerce has become one of the alternative shopping in addition to shopping in conventional marketplaces. The development of e-commerce is the result of the increasingly widespread role of technology use today. Meeting the expectations of performance aspects makes e-commerce like a "primadonna", an inclusive and unlimited digital era is one of the primary elements that make e-commerce warmly welcomed throughout the world. The thing that underlies fast-moving e-commerce in the modern world is because of the assumption that e-commerce is more comfortable and more practical (perceived usefulness) in its use and has been proven to be able to meet effort expectancy [5-9].

In this research, the original ECM was modified with the addition of 2 components, namely System Quality and Service Quality to adopt the use of e-marketplaces. And this is the contribution proposed in this study.

## **II. RELATED WORK**

Theoretical base – expectation–confirmation model (ECM) and investment model (IM) Past research has applied different technology usage models to explore users' continuance intention, such as UTAUT2 [10], TAM [11,12] and ECM [13]. Although these studies provide insights into understanding users' continuance usage of fitness and health apps, by primarily applying a single model and including limited factors, previous studies could only provide an insufficient explanation of individuals' postadoption behavior. On the other hand, to explore what contributes to a sustained relationship, the IM that was initially developed to understand interpersonal relationship has been applied in the technology context [14,15,16,17,18]. The IM addresses the limitation of the ECM, which primarily focuses on users' perceptions toward the IT product/service [19]. However, the IM theory has not yet been used to investigate the user–app relationship. Therefore, this study integrates the ECM and IM to address the utilitarian and commitment perspectives of individuals' usage of fitness and health apps [20].

Research conducted by Aslam et al [21] examines the ECM model used for mobile social commerce. This study used the expectation confirmation model (ECM) in developing the model related to continuance usage intention of mobile social commerce. For testing the relationships, structural equation modeling (SEM) is used by using Amos 22. The findings of the study will help the brands in understanding key determinants that help in building brand loyalty in the mobile social commerce context and will expand the literature of mobile social commerce in the context of developing economies. The study provides numerous implications for brand managers in boosting brand loyalty. The paper is organized as follows; section 2 represents the theoretical background and literature. Section 3 emphasizes the development of hypotheses. Details related to the methodology are presented in section 4. Section 5 presents the results. Lastly, section 6 presents conclusion, recommendation and future area to research.

**Expectation-Confirmation Model** The expectation-confirmation model is a framework used by researchers to explain and understand matters relating to consumer satisfaction, trust and sustainability in purchasing or using a service [22,23]. Besides, some researchers explained that ECM is adopted to explain acceptance, use or adoption of a technology [24,25,26]. ECM shows that consumer behavior in purchasing based on their own decisions, on the other hand, consumers will rely on their expectations of how well the services they receive. In addition, the information received by consumers with regard to the product or service will greatly affect the decision in purchasing; of course the information is expected to be accurate and reliable [27]. Meaning of expectation refers to how far the level of user satisfaction in feeling something, based on his experience using technology. Meanwhile, perceived usefulness is a feeling experienced by users to measure how far a person is believing the use of technology whether it is useful or not. Satisfaction is a positive emotional state resulting from the evaluation of the use of the technology, and continuance intention is useful as a reference to measure how far the customers intend to repurchase the technology or continue the use of the service [28]. If their expectations are met based on the use of such information technology, then the customers are likely to be satisfied and assume the technology is useful. In turn, customers tend to use technology continuously [28,29].

The adoption of e-commerce for generation Z has been researched by Lestari [30], in this study the variables used are Personal innovativeness, Self efficacy, Perceived usefulness, Perceived risk, Attitude, Intention.

In this study, we will use ECM development by adding a quality and service quality system to adopt the use of e-marketplaces.

### III. PROPOSED MODEL AND HYPOTHESIS

By using existing literature on research in the last six years regarding the adoption of e-commerce, mobile apps, and technology adoption, the model offered in this study is compiled as shown in Figure 1.

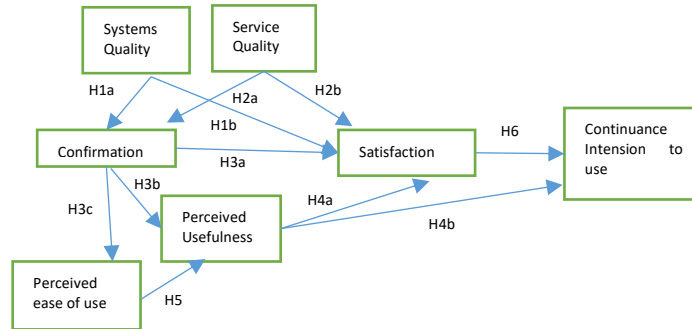

Fig. 1. Proposed model

#### A. System Quality, service Quality, Perceived Usefulness, and Confirmation on Satisfaction (H2b, H1b, H3a, H4a)

In Park's research [31] between system and service quality has a positive correlation to satisfaction. This is reinforced by research by Daghan, G and Akkoyunlu, B [32] that between System Quality and Service Quality has a positive correlation to Satisfaction, so that the H1b and H2b hypotheses can be made. Likewise, confirmation and Perceived Usefulness have a positive relationship with satisfaction [31,32,33,28], so hypotheses H3a and H4a can be made.

H1b: Systems Quality has a positive effect on Satisfaction

H2b: Service Quality has a positive effect on Satisfaction

H3a: Confirmation has a positive effect on Satisfaction

H4a: Perceived Usefulness has a positive effect on Satisfaction

#### B. System Quality and service Quality on Confirmation (H1a, H2a)

Gokhan [32] and Park [31] extended ECM with System and Service quality, based on this hypothesis H1a and H1b are made.

H1a: Systems Quality has a positive effect on Confirmation

H2a: Service Quality has a positive effect on Confirmation

#### C. Confirmation on Perceived Usefulness and Perceived Ease of Use (H3b, H3c)

According to Wijaya [29], Tam et al [33], and Park [31] Perceived Usefulness and Confirmation have a positive correlation. Meanwhile, Perceived Ease of Use and Confirmation also have a positive correlation [31], so that the H3b and H3c hypotheses can be compiled.

H3b: Confirmation has a positive effect on Perceived Usefulness

H3c: Confirmation has a positive effect on Perceived ease of use

#### D. Perceived ease of use on Perceived Usefulness (H5)

In the research of Tam et al [33] there is a positive correlation between Perceived ease of use and Perceived Usefulness, so the hypothesis H5 can be made.

H5: Perceived ease of use has a positive effect on Perceived Usefulness

#### E. Perceived Usefulness, satisfaction on Continuance Intension to use (H4b, H6)

In the ECM model [32,21,20,28,33] there is a positive correlation between Satisfaction and Continuance Intension to use and also Perceived Usefulness has a positive correlation with Continuance Intension to use [33,31,21,20]. On this basis, the hypotheses H4b and H6 are made.

H4b: Perceived Usefulness has a positive effect on Continuance Intension to use e-marketplace

H6: satisfaction has a positive effect on Continuance Intension to use e-marketplace

#### IV. METHODOLOGY

In this study used data from 217 respondents who were distributed randomly using google form. Of these 217 respondents, only 210 data were used, because there were some invalid data, so 7 pieces of data had to be removed.

The test model used is SEM PLS. Previously, the common bias variance was tested first to find out how much bias between the variables used in this study using SPSS (Harman's single factor test). After this common bias meets the requirements, which is less than 50% according to Harman's single factor test criteria, then the Measurement Model Test is carried out, namely testing the validity, reliability, and Multicollinearity. After the measurement model test, the next is the Structural Model Test which includes the path coefficients test, the Coefficient of Determination, and the Hypothesis Test.

The validity test consists of 2 stages, namely Convergent validity and Discriminant Validity, then continued to test the reliability by measuring the price of Cronbach alpha and Composite Reliability. The price of Cronbach's Alpha and Composite Reliability must be above 0.7.

The path coefficient test is determined from the value of the path coefficient, while the test for the ability of the independent variable in explaining the variance of the latent variable uses the R Square value. It is said to be strong if its R Square is greater than 0.26 (26%). The final step of this SEM test is to look at the hypothesis that has been prepared based on its P value, if it is above 0.05 then the hypothesis is rejected and vice versa below 0.05 then the hypothesis is accepted.

#### V. DATA ANALYSIS AND DISCUSSION

##### A. Demographic of Respondents

Demographics of respondents can be seen in table 1.

TABLE I. TABLE DEMOGRAPHICS RESPONDENS

Total Responden (n=210)		
<b>Age:</b>		
<20	37	18%
20-29	125	60%
30-39	24	11%
>=40	24	11%
<b>Gender:</b>		
Male	130	62%
Female	80	38%
<b>Education:</b>		
<High School	14	7%
Diploma - Undergraduate	161	77%
Master-Doctor	35	17%

From table 1 it can be seen that the most users are aged between 20-29 years with a Diploma-Undergraduate education level.

From this respondent's data, the following is a commond method bias test using the Harman's single factor test. The result is that the total value of% of the variance is 45.2%, which means that there is no bias between variables in the model because it is less than 50%.

##### B. Measurement Model Test

###### 1. Convergent validity

The model above is as in Figure 1 when tested with PLS, the results of outer loading can be seen in table 2 below:

TABLE II. THE LOADING FACTOR VALUE TO TEST THE VALIDITY OF THE INDICATOR

	CI	Con	PEoU	PU	SQ	SV	Sat
CI1	0.92						
CI2	0.931						
CI3	0.855						
Con1		0.841					
Con2		0.854					

Con3		0.86					
PEoU1			0.842				
PEoU 2			0.849				
PEoU 3			0.897				
PEoU 4			0.871				
PU 1				0.872			
PU 2				0.834			
PU3				0.783			
SQ1					0.795		
SQ2					0.809		
SQ3					0.865		
SQ4					0.785		
SV1						0.819	
SV2						0.853	
SV3						0.822	
Sat1							0.9
Sat2							0.923
Sat3							0.878

It can be seen that the value of each indicator loading outer value is greater than 0.7. To see the Average Variance Extracted (AVE) value can be seen in table 3.

TABLE III. NILAI AVERAGE VARIANCE EXTRACTED (AVE)

Variable	Average Variance Extracted (AVE)
CI	0.815
Con	0.725
PEoU	0.748
PU	0.641
SQ	0.626
SV	0.692
Sat	0.811

Based on Table 3, all variables have an AVE value above 0.5. From Table 2 and Table 3, it can be seen that this model meets the requirements for convergent validity.

## 2. Discriminant Validity

For the discriminant validity test, the Fornell-Lacker criterion was used, the results of this test can be seen in table 4.

TABLE IV. FORNELL-LARCKER CRITERION VALUES

	CI	Con	PEoU	PU	SQ	SV	Sat
CI	0.903						
Con	0.501	0.852					
PEoU	0.596	0.598	0.865				
PU	0.622	0.663	0.664	0.801			
SQ	0.53	0.702	0.63	0.652	0.791		
SV	0.575	0.768	0.637	0.663	0.706	0.832	
Sat	0.545	0.694	0.683	0.622	0.692	0.712	0.901

Based on the values listed in Table 4, each variable has the greatest value by itself compared to other variables. Therefore, this model qualifies for discriminant validity.

## 3. Reliability Test

Reliability refers to the consistency or stability of an indicator. Reliability is measured by the value of composite reliability and Cronbach's alpha. Table 5 will display the composite reliability and cronbach's alpha values of each construct.

TABLE V. THE VALUE OF COMPOSITE RELIABILITY AND CRONBACH'S ALPHA

	<b>Cronbach's Alpha</b>	<b>Composite Reliability</b>
CI	0.886	0.929
Con	0.811	0.888
PEoU	0.887	0.922
PU	0.719	0.841
SQ	0.797	0.869
SV	0.777	0.871
Sat	0.883	0.928

According to Table 5, it can be seen that all constructs have a composite reliability value above 0.7, which means that the variable is reliable.

### C. Structural Model Test

After doing the measurement model and this model has passed the measurement model test, the next step is to do the structural model test. The structural model test is to analyze the structural relationship between the measured variables and their latent variables. The structural model test includes path coefficients and coefficient of determination test.

#### 1. Test the path coefficients

The basis for determining whether a hypothesis is accepted or not using path coefficients. The results can be seen in table 6.

TABLE VI. VALUE OF PATH COEFFICIENTS

	<b>CI</b>	<b>Con</b>	<b>PEoU</b>	<b>PU</b>	<b>SQ</b>	<b>SV</b>	<b>Sat</b>
CI							
Con			0.598	0.413			0.197
PEoU				0.418			
PU	0.462						0.027
SQ		0.317					0.205
SV		0.544					0.221
Sat	0.258						

From table 6 it can be seen that the value less than 0.1 is from PE to Sat, which means that the PE variable is not correlated with the Sat variable.

#### 2. Coefficient of Determination

Testing the coefficient of determination or R<sup>2</sup> aims to find out how accurate the prediction of the model made in this study is. The coefficient of determination explains how much the ability of the independent variable to explain the variance of the latent variable. The results of the interpretation of the coefficient of determination can be classified into 3 levels, namely small, medium or large effect size. Table 7 shows the coefficient of determination of the three factors used in the research model.

TABLE VII. R SQUARE AND R SQUARE ADJUSTED VALUES

	<b>R Square</b>	<b>R Square Adjusted</b>
CI	0.428	0.422
Con	0.641	0.637

PEoU	0.357	0.354
PU	0.551	0.547
Sat	0.642	0.633

All determination values are above 0.26 or 26% which means large effect size (strong)

### 3. Hypothesis testing

Hypothesis testing was carried out using a two-tailed test by comparing p-values with a significance level of 5%. The results of hypothesis testing using SmartPLS will produce mean, standard deviation, t-statistics, and p-values. Hypothesis testing is conducted to check the structural validity of the model and determine which hypotheses are accepted and rejected from the comparison of p-values and significance levels. If the p-value is below 5%, the hypothesis will be accepted and if the p-value is above 5%, the hypothesis will be rejected.

TABLE VIII. HYPOTHESIS TEST RESULTS

	Sample Mean (M)	Standard Deviation (STDEV)	T Statistics ((O/STDEV))	P Values	Hypothesis
Con -> PEoU	0.595	0.064	9.342	0	Accepted
Con -> PU	0.414	0.054	7.618	0	Accepted
Con -> Sat	0.194	0.083	2.39	0.017	Accepted
PEoU -> PU	0.417	0.055	7.59	0	Accepted
PU -> CI	0.463	0.066	7.031	0	Accepted
PU -> Sat	0.03	0.066	0.411	0.681	Rejected
SQ -> Con	0.315	0.066	4.814	0	Accepted
SQ -> Sat	0.2	0.076	2.711	0.007	Accepted
SV -> Con	0.546	0.064	8.474	0	Accepted
SV -> Sat	0.226	0.087	2.548	0.011	Accepted
Sat -> CI	0.258	0.072	3.59	0	Accepted

From table 8, it can be seen that all the hypotheses are support, except for H4a not support because the P value is above 5% or 0.05. The following is a picture of the model after testing the hypothesis.



Fig. 2. The final model after testing. \*p < 0.05, \*\*p < 0.01, \*\*\*p = 0

The findings in this study are that the largest users of e-marketplaces are people aged between 20-29 years with a diploma and undergraduate education level, namely 60% of 210 respondents.

Based on Figure 2, it can be seen that almost all of the hypotheses made in this study are accepted except for hypothesis 4a, namely Perceived Usefulness has an effect on user satisfaction. This is because most e-marketplace users are not satisfied with the benefits of shopping online, they still like to shop offline, they can see firsthand the items they are going to buy and they can also try or taste these items. This is in line with the research of Aslam et al, Prasetya and Harnadi [21,34] who also have the same result, namely Perceived Usefulness does not affect Satisfaction.



In Hypotheses 1a and 1b, namely the effect of the Quality System on Confirmation and Satisfaction, this is true or acceptable because e-marketplaces that have a good quality system will have an effect on confirmation from the user and will also lead to a feeling of satisfaction for the user. This is in line with research conducted by the 2017 gokhan [32]

Hypotheses 2a and 2b, namely the effect of Service Quality on Confirmation and Satisfaction, have been proven from the results of statistical tests, this proves that an e-marketplace that has good service will make its customers feel that it is what they expect and also make them satisfied. If customers feel satisfied, then they will usually become loyal customers.

If customers feel satisfied with the quality system and good service quality from the e-marketplace, then this will make customers loyal and will continue to use the e-marketplace.

From this research, it is proven that the desire to continue using the e-marketplace platform is determined by Perceived Usefulness and Satisfaction. This result implies that e-marketplace players and developers who have a strong interest in loyalty to attract their interest in using the platform in a sustainable manner.

## REFERENCES

- [1] Lawrence, J.E., Tar, U.A., "Barriers to ecommerce in developing countries," *Inform. Soc. Justice*, vol. 3, no. 1, pp. 23–35, 2010
- [2] E. Brynjolfsson, Y. (Jeffrey) Hu, and M. S. Rahman, "Battle of the Retail Channels: How Product Selection and Geography Drive Cross-Channel Competition," *Manage. Sci.*, vol. 55, no. 11, pp. 1755–1765, 2009, doi: 10.1287/mnsc.1090.1062.
- [3] T. M. Nisar and G. Prabhakar, "What factors determine e-satisfaction and consumer spending in e-commerce retailing?," *J. Retail. Consum. Serv.*, vol. 39, no. July, pp. 135–144, 2017, doi: 10.1016/j.jretconser.2017.07.010.
- [4] R. Z. Kuo, "EMRS Adoption: Exploring the effects of information security management awareness and perceived service quality," *Heal. Policy Technol.*, vol. 7, no. 4, pp. 365–373, 2018, doi: 10.1016/j.hlpt.2018.10.012.
- [5] Oh, J.-C., & Yoon, S.-J., "Predicting The Use of Online Information Services Based On A Modified UTAUT Model," *Behaviour & Information Technology*, vol.33, no. 7, pp. 716–729, 2014.
- [6] Ramayasa, I. P., "Evaluation Model of Success And Acceptance of e-Learning," *Journal of Theoretical and Applied Information Technology*, vol 82, no. 3, pp. 462, 2015.
- [7] Farzin, S., & Dahlan, H. M., "Proposing A Model To Predict Students' perception Towards Adopting An E-Assessment System," *Journal of Theoretical & Applied Information Technology*, vol. 90, no. 1, 2016.
- [8] Malik Bader Alazzam, A., Samad Hasan Basari, A. S. S., Ibrahim, Y. M., Ramli, M. R., & Naim, M. H., "Trust In Stored Data In Ehra Acceptance Of Medical Staff: Using UTAUT2," *International Journal of Applied Engineering Research*, vol. 11, no. 4, pp. 2737–2748, 2016.
- [9] D. M. Mansur, E. T. Sule, D. Kartini, Y. M. Oesman, A. H. P. K. Putra, and N. Chamidah, "Moderating of the role of technology theory to the existence of consumer behavior on e-commerce," *J. Distrib. Sci.*, vol. 17, no. 7, pp. 15–25, 2019, doi: 10.15722/jds.17.07.201907.15.
- [10] Yuan, S., Ma, W., Kanthawala, S. and Peng, W., "Keep using my health apps: discover users' perception of health and fitness apps with the UTAUT2 model", *Telemedicine and e-Health*, Vol. 21 No. 9, pp. 735-741, 2015.
- [11] Beldad, A.D. and Hegner, S.M., "Expanding the technology acceptance model with the inclusion of trust, social influence, and health valuation to determine the predictors of German users' willingness to continue using a fitness app: a structural equation modeling approach", *International Journal of Human-Computer Interaction*, Vol. 34 No. 9, pp. 882-893, 2018.
- [12] Chen, M.-F. and Lin, N.-P., "Incorporation of health consciousness into the technology readiness and acceptance model to predict app download and usage intentions", *Internet Research*, Vol. 28 No. 2, pp. 351-373, 2018.
- [13] Cho, J., "The impact of post-adoption beliefs on the continued use of health apps", *International Journal of Medical Informatics*, Vol. 87, pp. 75-83, 2016.

- [14] Giovanis, A., "Consumer-brand relationships' development in the mobile internet market: evidence from an extended relationship commitment paradigm", *The Journal of Product and Brand Management*, Vol. 25 No. 6, pp. 568-585, 2016.
- [15] Giovanis, A. and Athanasopoulou, P., "Consumer-brand relationships and brand loyalty in technology-mediated services", *Journal of Retailing and Consumer Services*, Vol. 40, pp. 287-294, 2018.
- [16] Uysal, A., "Commitment to multiplayer online games: an investment model approach", *Computers in Human Behavior*, Vol. 61, pp. 357-363, 2016.
- [17] Odrowska, A.M. and Massar, K., "Predicting guild commitment in World of Warcraft with the investment model of commitment", *Computers in Human Behavior*, Vol. 34, pp. 235-240, 2014.
- [18] Lin, J.-S., Sung, Y. and Chen, K.-J., "Social television: examining the antecedents and consequences of connected TV viewing", *Computers in Human Behavior*, Vol. 58, pp. 171-178, 2016.
- [19] Jin, X.-L., Lee, M.K.O. and Cheung, C.M.K., "Predicting continuance in online communities: model development and empirical test AU -Jin, Xiao-Ling", *Behaviour and Information Technology*, Vol. 29 No. 4, pp. 383-394, 2010.
- [20] W. Chiu, H. Cho, and C. G. Chi, "Consumers' continuance intention to use fitness and health apps: an integration of the expectation–confirmation model and investment model," *Inf. Technol. People*, 2020, doi: 10.1108/ITP-09-2019-0463.
- [21] Aslam, W., Ham, M. and Farhat, K., "Building Brand Loyalty: An Application of Expectation Confirmation Model in Mobile Social Commerce," *Journal of Commerce and Social Sciences*, Vol. 13, no.4, pp. 806-825, 2019.
- [22] Fan, L., & Suh, Y. H., "Why do users switch to a disruptive technology? An empirical study based on expectation-disconfirmation theory," *Information & Management*, vol. 51, no. 2, pp. 240–248, 2014.
- [23] Kim, D. J., Ferrin, D. L., & Rao, H. R., "Trust and satisfaction, two stepping stones for successful e-commerce relationships: A longitudinal exploration," *Information systems research*, vol. 20, no. 2, pp. 237-257, 2009.
- [24] Bhattacharjee, A., & Premkumar, G., "Understanding changes in belief and attitude toward information technology usage: A theoretical model and longitudinal test," *MIS quarterly*, vol. 28, pp. 229-254, 2004.
- [25] Halilovic, S., & Cicic, M., "Antecedents of information systems user behaviour–extended expectation-confirmation model," *Behaviour & Information Technology*, vol. 32, no. 4, pp. 359-370, 2013.
- [26] Stone, R. W., & Baker-Eveleth, L., "Students' expectation, confirmation, and continuance intention to use electronic textbooks," *Computers in Human Behavior*, vol. 29, no. 3, pp. 984–990, 2013.
- [27] Wu, I. L., "The antecedents of customer satisfaction and its link to complaint intentions in online shopping: An integration of justice, technology, and trust," *International Journal of Information Management*, vol. 33, no. 1, pp. 166–176, 2013.
- [28] Bhattacharjee, A., "Understanding information systems continuance: an expectation-confirmation model," *MIS Quarterly*, vol. 25, pp. 351-370, 2001.
- [29] I. W. K. Wijaya, A. A. G. Rai, and T. Hariguna, "The impact of customer experience on customer behavior intention use in social media commerce, an extended expectation confirmation model: An empirical study," *Manag. Sci. Lett.*, vol. 9, no. 12, pp. 2009–2020, 2019, doi: 10.5267/j.msl.2019.7.005.
- [30] D. Lestari, "Measuring e-commerce adoption behaviour among gen-Z in Jakarta, Indonesia," *Econ. Anal. Policy*, vol. 64, pp. 103–115, 2019, doi: 10.1016/j.eap.2019.08.004.
- [31] E. Park, "User acceptance of smart wearable devices: An expectation-confirmation model approach," *Telemat. Informatics*, vol. 47, no. December 2019, 2020, doi: 10.1016/j.tele.2019.101318.
- [32] G. Daňhan and B. Akkoyunlu, "Modeling the continuance usage intention of online learning environments," *Comput. Human Behav.*, vol. 60, pp. 198–211, 2016, doi: 10.1016/j.chb.2016.02.066.
- [33] C. Tam, D. Santos, and T. Oliveira, "Exploring the influential factors of continuance intention to use mobile Apps: Extending the expectation confirmation model," *Inf. Syst. Front.*, vol. 22, no. 1, pp. 243–257, 2020, doi: 10.1007/s10796-018-9864-5.

[34] F. X. H. Prasetya and B. Harnadi, "Investigation of Adoption of Smartphone Technology for Learning," ICSEC 2019 - 23rd Int. Comput. Sci. Eng. Conf., pp. 251–254, 2019, doi: 10.1109/ICSEC47112.2019.8974802.

## VII. Hasil Uji Coba Website Industri Kreatif

Dokumen dan video Uji Coba Website E-Marketplace secara lengkap merupakan Luaran Wajib yang telah diupload secara terpisah dalam sistem Simlibtabmas. Namun secara ringkas dapat diringkas sebagai berikut:

Uji Coba dilakukan sebanyak 3 kali:

1. Hasil Pengujian I WEB E-Marketplace dcreatifunika.id dari sisi pelapak/seller  
Tanggal Pelaksanaan 7 Nov 2020

Tempat: Ruang Virtual Gmeet

Responden: 52 orang sebagai seller

Hasil Technology Readines Index (TRI) Responden:

- Optimisme : 4.036363636
- Inovasi : 3.695454545
- Ketidaknyamanan : 2.868181818
- Ketidakamanan : 3.563636364

Faktor yang digunakan untuk Pengujian Website:

- Tampilan Web
- Desain Responsive
- Fungsionalitas Web
- Navigasi Web
- Performa Web

Terdapat banyak saran dan masukan terkait faktor diatas yang digunakan bagi penyempurnaan sistem Web dari sisi pelapak/seller

2. Hasil Pengujian II WEB E-Marketplace dcreatifunika.id dari sisi pelapak/seller  
Tanggal Pelaksanaan 26 Nov 2020

Tempat: Ruang Virtual Zoom

Responden: 8 orang sebagai seller

Hasil Technology Readines Index (TRI) Responden:

- Optimisme : 3.96875
- Inovasi : 4.09375
- Ketidaknyamanan : 2.84375
- Ketidakamanan : 3.21875

Faktor yang digunakan untuk Pengujian Website:

- Tampilan Web
- Desain Responsive
- Fungsionalitas Web
- Navigasi Web
- Performa Web

Terdapat banyak saran dan masukan terkait faktor diatas yang digunakan bagi penyempurnaan sistem Web dari sisi pelapak/seller

3. Hasil Pengujian III WEB E-Marketplace dcreatifunika.id dari sisi pembeli/buyer (26 Nov 2020)  
Tanggal Pelaksanaan 26 Nov 2020

Tempat: Ruang Virtual Zoom

Responden: 52 orang sebagai seller

Hasil Technology Readines Index (TRI) Responden:

- Optimisme : 4.068181818

- Inovasi : 3.781960227
- Ketidaknyamanan : 2.982954545
- Ketidakamanan : 3.448863636

Faktor yang digunakan untuk Pengujian Website:

- Tampilan Web
- Desain Responsive
- Fungsionalitas Web
- Navigasi Web
- Performa Web

Terdapat banyak saran dan masukan terkait faktor diatas yang digunakan bagi penyempurnaan sistem Web dari sisi pembeli/buyer

### **VIII. FGD Review Website dan Aplikasi dengan Pakar dan Pelaku Industri Kreatif**

FGD dengan pakar dan pelaku Industri kreatif dilakuka dengan menggandeng Pakar web (Pengembang web profesional) Bapak Andre Kurniawan, ST, M.Ling dan Pendamping UMKM Ibu Dr. Yekti P., SE, MSi.

Pelaksanaan FGD: Kamis, 3 Desember 2020

Lokasi: R.Rapat Pendidikan Doktoral Ilmu Lingkungan Gd. Theater It.2.

Masukan yang didapat dari pelaksanaan FGD:

Pak Andre : Masih ada kelemahan di fintech nya, sehingga masih diperlukan penelitian lebih lanjut. Sementara yang ada hanya raja ongkir. Raja ongkir setiap transaksi kena biaya 4 rb rupiah per transaksi.

Pak Yoga : Untuk pembayaran yang paling mungkin COD dan lewat transfer.

Pak Andre : Punya usulan kalau pembayaran pakai Q rise, per transaksi hanya di kenai 0.56% per transaksi. Bu Ibu Yekti : mengusulkan pakai youtab.

Pak Yoga : Sistem hanya menyediakan untuk berdagang saja, antara penjual dan pembeli transaksi keuangan bisa di atur tersendiri. Modelnya kayak olx (pak berdi)

Bu Yekti : Bila memilih sistem seperti OLX, cara memfilter biar tidak sembarangan pelapak bisa masuk? Perlu dipikirkan otentikasi pembuat akun.

Bu yekti : Bagi E-Marketplace UMKM, ada tempat bagi penjual dan pembeli ketemu. Perlu dipikirkan fintech yang cocok bagi UMKM.

Bu Yekti : Bagi umkm memang difasilitasi oleh toko pedia, buka lapak. Tetapi akhirnya juga tidak jalan.

Bu Yekti : Diharapkan web ini berfungsi dengan baik dan bisa digunakan sebaik-baiknya untuk UMKM. Bagaimana cara buat kuncinya (pertanyaan bu Yekti), jawaban pak berdi dengan register yang harus di validasi oleh admin.

Pak Andre : Masih terdapat link yang kosong.

### **IX. Pengembangan Aplikasi Android**

Hasil pembuatan versi Aplikasi android terlihat pada anak panah dibawah ini:

Tampilan Awal untuk tampilan android bisa dilihat pada Gambar 17.

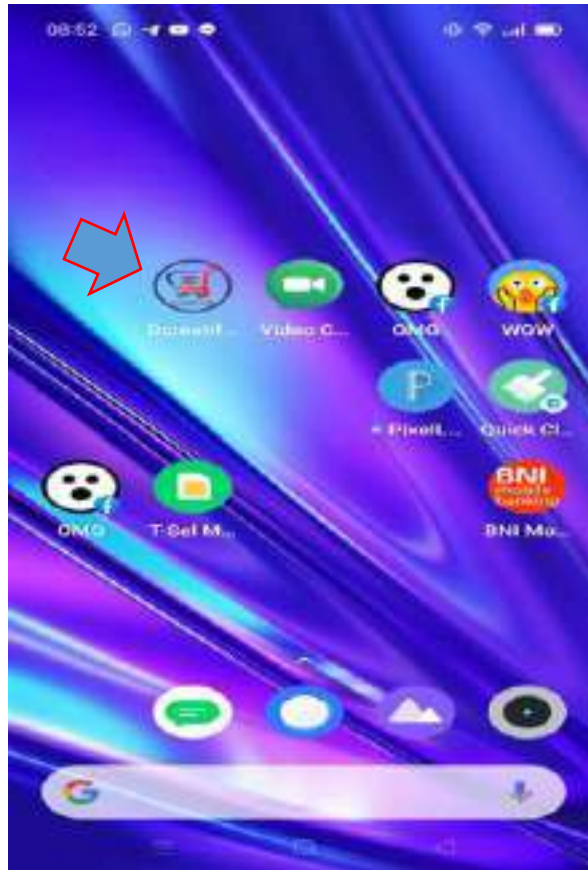

Gambar 17. Tampilan aplikasi di Mobile Android

Setelah masuk ke tampilan utama, selanjutnya masuk ke menu utama, sebelumnya terdapat splash saat masuk menu utama, bisa dilihat pada Gambar 18.



Gambar 18. Tampilan splash saat masuk ke menu utama

Selanjutnya adalah tampilan APK dcreatifunika pada tampilan utama bisa dilihat pada Gambar 19.



Gambar 19. Tampilan Utama Aplikasi Android untuk Web dcreatifunika.

Selanjutnya untuk melihat kategori produk bisa dilihat pada Gambar 20.

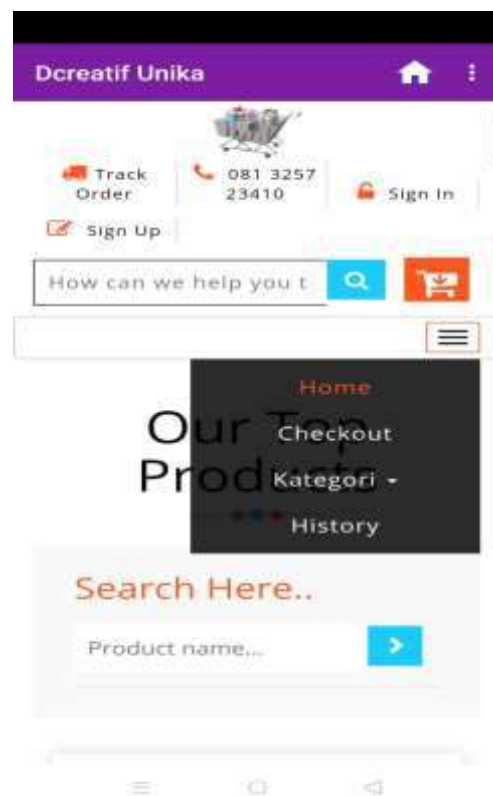

Gambar 20. Tampilan untuk melihat kategori produk

Berikutnya melakukan registrasi, bisa dilihat tampilannya pada Gambar 21.

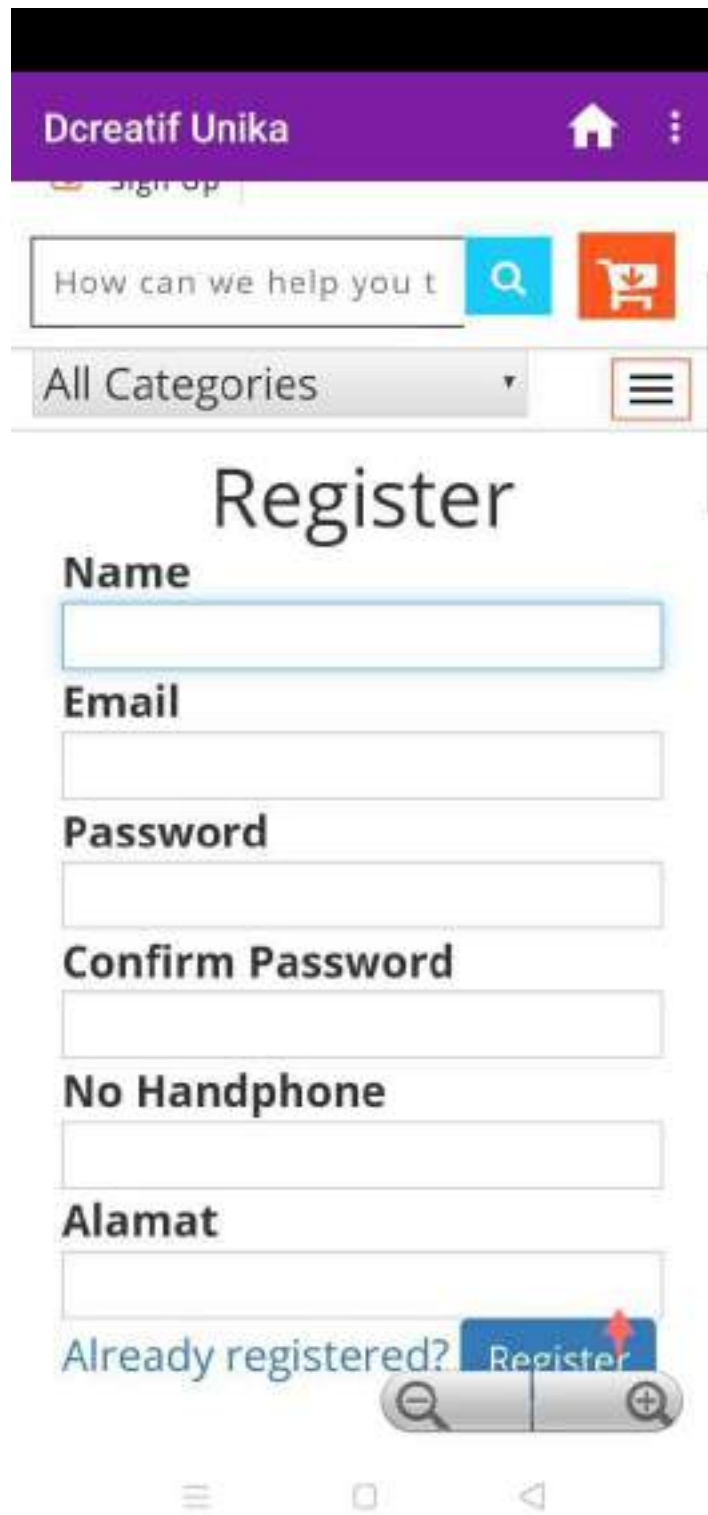

The image shows a mobile application interface for 'Dcreatif Unika'. At the top, there is a purple header with the app name, a home icon, and a menu icon. Below the header is a search bar with the placeholder text 'How can we help you t', a magnifying glass icon, and a shopping cart icon. Underneath the search bar is a category dropdown menu set to 'All Categories' and a hamburger menu icon. The main content area is titled 'Register' and contains several input fields: 'Name', 'Email', 'Password', 'Confirm Password', 'No Handphone', and 'Alamat'. At the bottom of the form, there is a link 'Already registered?' and a blue 'Register' button with a red arrow pointing to it. The bottom of the screen shows a mobile navigation bar with a search icon, a home icon, and a back icon.

Gambar 21. Tampilan untuk registrasi

Selanjutnya adalah melakukan login. Untuk bisa login kita harus registrasi dulu. Tampilan login bisa dilihat pada Gambar 22.

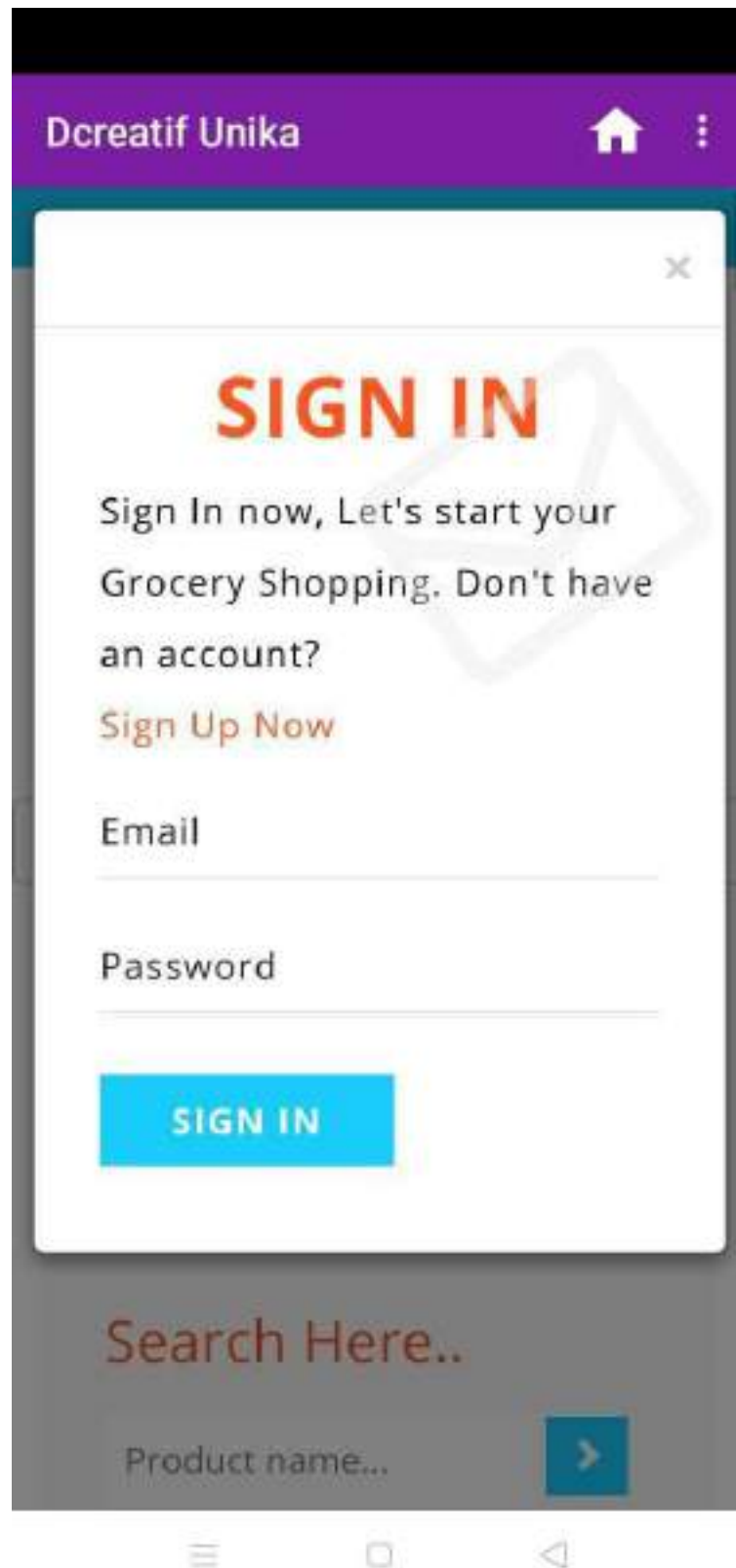

Gambar 22. Tampilan untuk Login  
Setelah login kita akan masuk ke menu utama seperti pada Gambar 19.



Selanjutnya adalah jika ingin melakukan pembelian, maka bisa dilakukan dengan menekan tombol add to cart seperti pada Gambar 23.



Gambar 23. Tampilan untuk melakukan pembelian

Setelah memilih produk yang akan dibeli berikutnya adalah memasukkan jumlah yang akan di beli. Seperti pada Gambar 24.

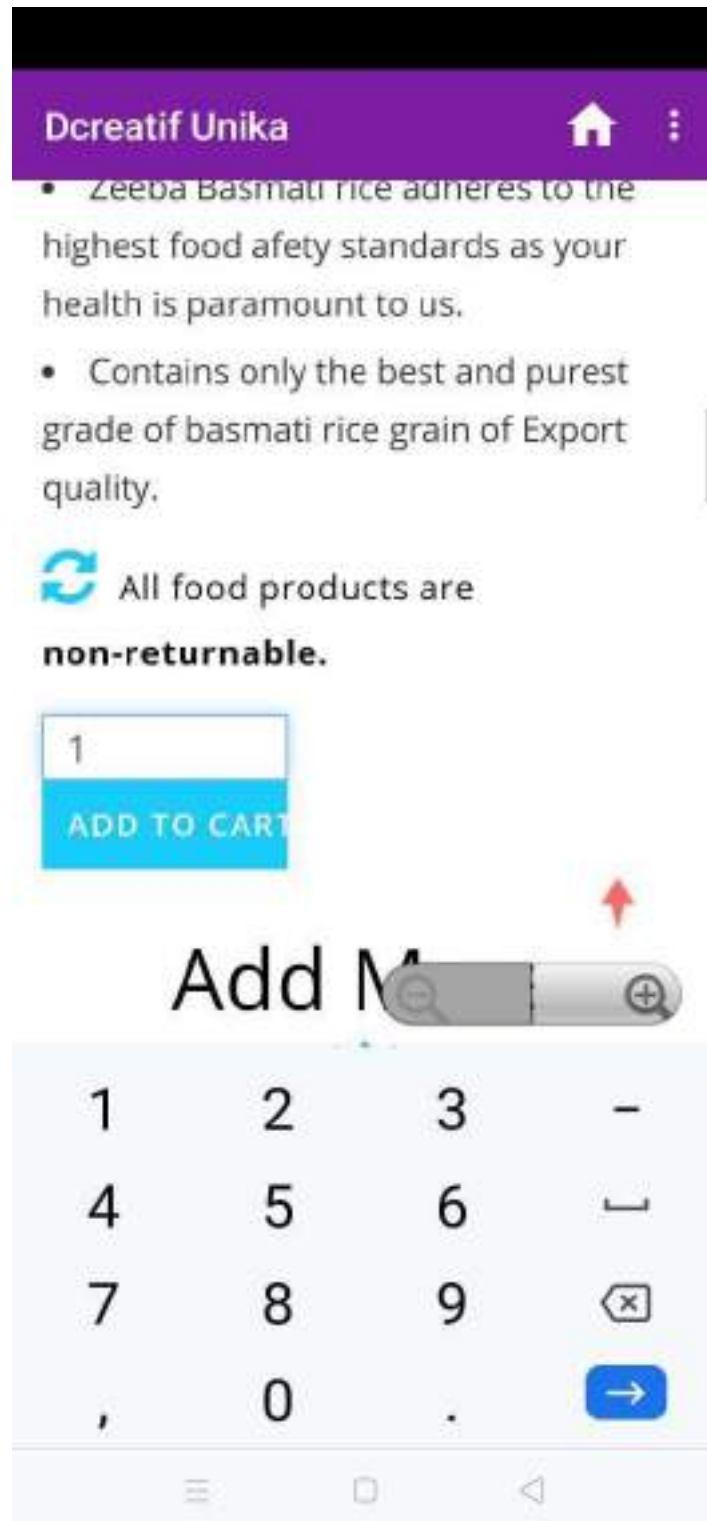

Gambar 24. Tampilan untuk memasukkan jumlah yang akan dibeli.

Setelah mengisi jumlah yang akan dibeli, selanjutnya adalah meng klik check out. Tampilannya seperti pada Gambar 25.

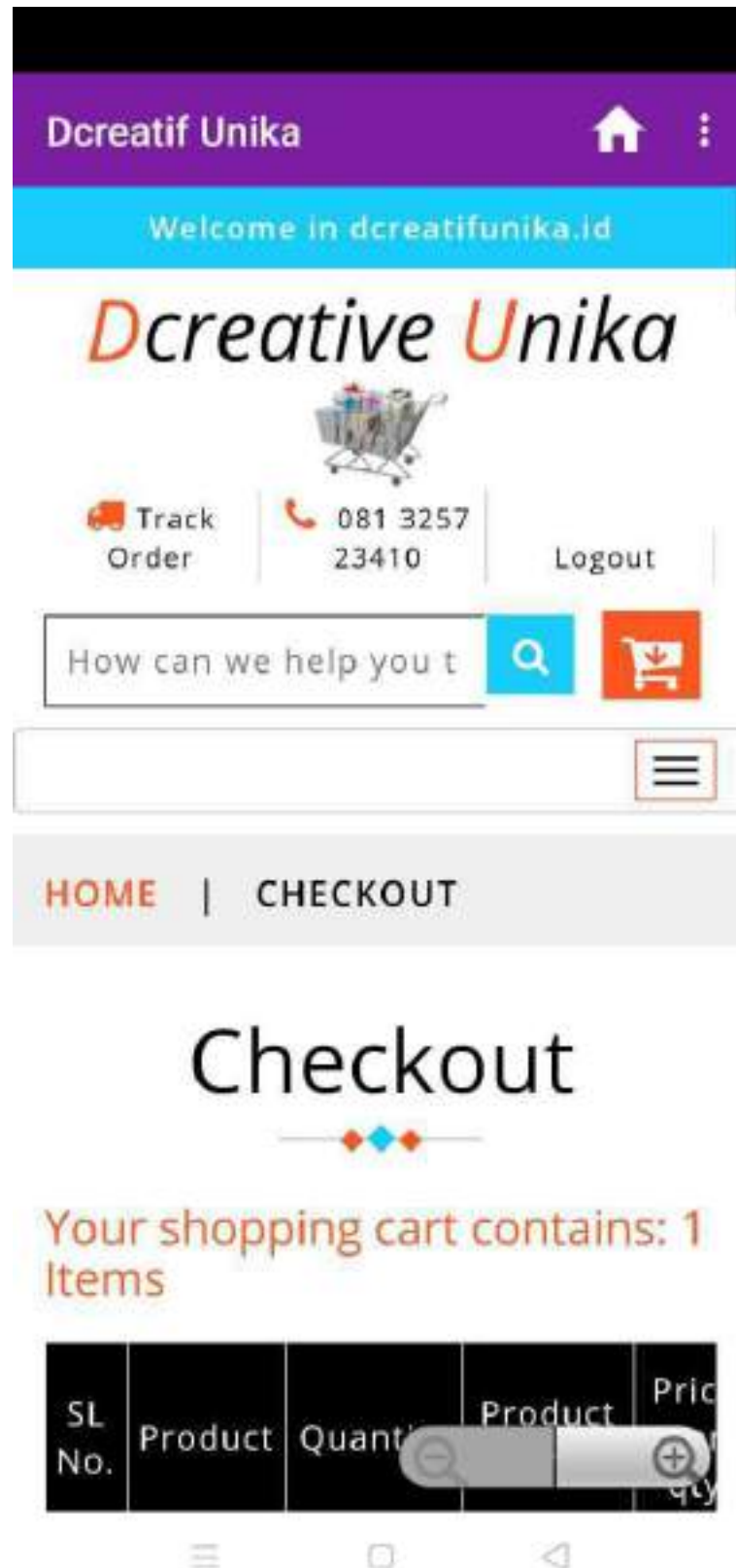

Gambar 25. Tampilan check out

Selanjutnya adalah kita bisa melihat histori, barang apa saja yang sudah kita beli. Tampilannya bisa dilihat pada Gambar 26.



Gambar 26. Tampilan History pembelian

#### X. Workshop Pemanfaatan Website dan Aplikasi

Workshop Pemanfaatan Website dan Aplikasi android sistem e-marketplace bagi UMKM dilaksanakan

Sabtu, 4 Desember dengan mengundang UMKM jaringan Unika untuk mendapatkan pelatihan tentang pemanfaatan dan penggunaan platform e-marketplace dan sekaligus launching perdana website e-commerce dcreatifunika.ac.id.

### XI. Pengajuan HKI

Obyek Website E-marketplace dcreatifunika.id diajukan HKI dengan jenis program aplikasi web. Pengajuan ini untuk pengakuan hak kekayaan intelektual dari sistem E-Marketplace yang dirancang dan dibangun dalam skema penelitian.

Berikut ini adalah bukti penerimaan untuk pengajuan HKI pada Gambar 27, sertifikat HKI pada Gambar 28a dan Gambar 28b.

**Formulir Permohonan Pencatatan Ciptaan**

Data Permohonan		
Nomor Permohonan	:	EC00202056509
Tanggal Pengajuan	:	06-12-2020
Jenis Ciptaan	:	Program Komputer
Judul Ciptaan	:	Aplikasi E-marketplace Digital Kreatif dcreatifunika.id
Uraian Ciptaan	:	Aplikasi e-marketplace digital kreatif dcreatifunika.id adalah aplikasi yang digunakan untuk proses jual beli secara online. Aplikasi ini menggunakan nama domain dcreatifunika.id dikembangkan dengan menggunakan Bahasa pemrograman PHP berbasis Object Oriented Programming
Tanggal dan tempat diumumkan pertama kali	:	Semarang, 20-09-2020

Pencipta		
Nama	Alamat	Kebangsaan
Bernardinus Hamadi, ST, MT, PhD	Jl. Karang roto blok A RT3/RW4 no 20	Indonesia
Albertus Dwiyoga Widiantoro, S.Kom, M.Kom	Jl. Griya Sekar Gading Blok C No. 8 Kalisegoro Gunungpati	Indonesia
FX. Hendra Prasetya, ST, MT	Jl. Kepodang Barang 4 blok C no 50 Pudak Payung	Indonesia
Dey Nikolas Suhendra	Jl. Barito no 30	Indonesia

Pemegang		
Nama	Alamat	Kebangsaan
LPPM Universitas Katolik Soegijapranata	Jl. Pawiyatan Luhur N/1, Bendan Duwur	Indonesia

Kuasa		
Nama	Alamat	Kota
LPPM Universitas Katolik Soegijapranata	Jl. Pawiyatan Luhur N/1, Bendan Duwur	Semarang

Lampiran		
Surat Kuasa (Melalui Konsultan) Akta Perusahaan KTP NPWP Peringatan Bukti Detail		

Jakarta, 06-12-2020  
Pemohon/Kuasa

l.l.d.



Gambar 27. Screenshot bukti pendaftaran HKI



REPUBLIK INDONESIA  
KEMENTERIAN HUKUM DAN HAK ASASI MANUSIA

## SURAT PENCATATAN CIPTAAN

Dalam rangka perlindungan ciptaan di bidang ilmu pengetahuan, seni dan sastra berdasarkan Undang-Undang Nomor 28 Tahun 2014 tentang Hak Cipta, dengan ini menerangkan:

Nomor dan tanggal permohonan : EC00202056509, 6 Desember 2020

**Pencipta**

Nama : Bernardinus Harnadi, ST., MT., PhD, Albertus Dwyoga Widianoro, S.Kom., M.Kom dkk

Alamat : Jl. Karang Roto Blok A RT3/RW4 No 20, Semarang, JAWA TENGAH, 50117

Kewarganegaraan : Indonesia

**Pemegang Hak Cipta**

Nama : LPPM Universitas Katolik Soegijapranata

Alamat : Jl. Pawiyatan Luhur IV/1, Benda Duwur, Semarang, JAWA TENGAH, 50234

Kewarganegaraan : Indonesia

Jenis Ciptaan : Program Komputer

Judul Ciptaan : Aplikasi E-marketplace Digital Kreatif Dcreatifunika.id

Tanggal dan tempat diumumkan untuk pertama kali di wilayah Indonesia atau di luar wilayah Indonesia : 20 September 2020, di Semarang

Jangka waktu perlindungan : Berlaku selama 50 (lima puluh) tahun sejak Ciptaan tersebut pertama kali dilakukan Pengumuman.

Nomor pencatatan : 000224597

adalah benar berdasarkan keterangan yang diberikan oleh Pemohon.  
Surat Pencatatan Hak Cipta atau produk Hak terkait ini sesuai dengan Pasal 72 Undang-Undang Nomor 28 Tahun 2014 tentang Hak Cipta.

a.n. MENTERI HUKUM DAN HAK ASASI MANUSIA  
DIREKTUR JENDERAL KEKAYAAN INTELEKTUAL



Dr. Freddy Harris, S.H., LL.M., ACCS.  
NIP. 19661181994031001

**Disclaimer:**

Dalam hal pemohon memberikan keterangan tidak sesuai dengan surat pernyataan, Menteri berwenang untuk mencabut surat pencatatan pemohon.

Gambar 28a. Serifikat HKI

#### LAMPIRAN PENCIPTA

No	Nama	Alamat
1	Bernardinus Harnadi, ST., MT., PhD	Jl. Karang Foto Blok A RT3/RW4 No 20
2	Albertus Dwiyoga Widianoro, S.Kom., M.Kom	Jl. Griya Sekar Gading Blok C No. 8 Kalisegoro Gunungpati
3	FX. Hendra Prasetya, ST., MT	Jl. Kepodang Barang 4 Blok C No 50 Pudak Payung
4	Oey Nikolas Suhendra	Jl. Barito No 30



Gambar 28b. Lampiran HKI

## XII. Publikasi Seminar Nasional

Rencana Publikasi pada seminar nasional. Data paper dan seminar sebagai berikut:

Nama Seminar:

2021 3rd EAST INDONESIA CONFERENCE ON COMPUTER AND INFORMATION TECHNOLOGY (EIconCIT)

Judul paper:

*Examining the Adoption of Mobile Payment Service: Expectation Confirmation Model with Trust*

Penulis:

Albertus Dwiyoga Widianoro, FX. Hendra Prasetya, Bernardinus Harnadi.

Penyelenggara:

Institut Sains & Teknologi Terpadu Surabaya, Indonesia

Pelaksanaan Seminar:

9 - 11 April 2021

Hasil penelitian yang dikirimkan ke seminar ini:

*Abstract*— This study has a purpose to examine the acceptance of mobile payment services by employing a modified ECM model with Trust. Several related studies on e-commerce and mobile payment have been investigated to derive important variables which can be employed on a proposed model. The model expresses the effect of customers' trust on their satisfaction in using mobile payment services and their continuance intention in using it. The online questionnaires constructed based on the proposed model were distributed to mobile payment users to gather their perceptions in using it. The 338 questionnaires gathered were analyzed statistically by SEM to test the hypotheses of the study. The results of the analysis reveal that customers' trust is an important variable to enhance customers' satisfaction and continuance intention in using mobile payment services. Other results indicate that Trust and Confirmation have a direct effect on the Perceived Usefulness of the services. Furthermore, both Perceived Usefulness and Trust will make consumers feel satisfied and tend to continuance their intention in using mobile payment services. This study contributes to financial service providers in delivering an obviousness, how was the trust of services can make consumers feel satisfy and use the service continually.

Keywords—ECM, Trust, mobile payment, SEM, Continuance Intention

### I. INTRODUCTION

Mobile Payment is a non-cash payment instrument using a cellular phone (Smartphone) as a device. Mobile payment methods use various media, such as NFC, QR Code, OTP (One Time Password).

Mobile payment (MP) is currently often used to make payments in various types of transactions. In Indonesia, there are many mobile payments which are divided into three categories, players from telecommunication companies are Dompetku, T-Cash, FlexiCash, Cash by XL. From banking companies, there are Mandiri e-Cash, Rekening Ponsel, Mega Virtual, BBM Money, Sakuku by BCA. From other backgrounds (technology startups) there are Go-Pay, Ovo, DANA, Doku, PayPro, and PayAcces.

Indonesia according to the Global Payment Report is the largest market in Southeast Asia. Indonesia is the fourth most populous country globally and contains the largest regional middle class. Financial Technology is in second place with a 25% market share.

In Indonesia, transactions using mobile payments have experienced significant growth. Mobile payment innovation has become an important part of his life. The mobile payment system has been used by many people in urban areas. This will certainly affect their daily life.

Although mobile payment has seen its growth, this study will dig deeper about the sustainability of using mobile payment technology.

From this study, we can find the post-adoption behavior of transactions in fulfilling daily needs in the context of mobile payments, which involve trusts. which may hinder the continued use of the user. Therefore, it is necessary to conduct empirical research to identify the factors that influence the continued use of mobile payments.

The expectation confirmation model (ECM) believes that users' intentions to use specific information systems and services are positively determined by their overall satisfaction in using the systems and services. Concerning smart services and products, the relationship between user-perceived satisfaction and the intention to use services and products has been consistently handled (Park, 2020). User satisfaction is a highly socialized activity that is not only influenced by the perceived benefits themselves but is also influenced by organizational support [1].

A number of studies have investigated the relationship between trust and customer adoption behavior. In the context of digital payments and mobile banking, trust is very important because of the threat of privacy and security issues [2]. Trust in technology can encourage users to adopt IT, which leads to a situation where end users can learn and understand the use of IT [3].

Customers rely on online service providers for accurate and current information; demonstrated that providing higher quality information (i.e. information that is relevant, highly understandable, accurate, complete and timely) increases the level of trust.

## II. Proposed model and Hypothesis

The model proposed in this study can be seen in Figure 1 below:

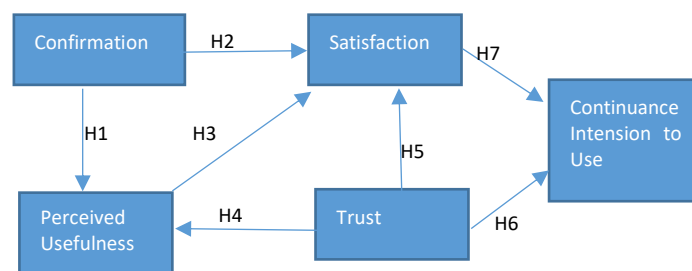

Fig. 1. The model used in this study

Continuance intention to use is Understanding continuous use or (as opposed to initial use or "acceptance"). This continues at the individual user level where individuals use the tool on a continuous basis. By using it can lead to the next life By using it continuously people will get an effective customer base, market share. The revenue of these companies depends on the number of initial users (new subscriptions) and the number of continuous users (subscription renewals)[4].

Trust refers to customers' beliefs about the integrity, policies and capabilities of service providers. Trust that increases customers' willingness to always use digital services for financial transactions [5].

Perceived usefulness is a core variable in TAM for explaining behavioral intentions. PU is defined as the extent to which a person believes that using a certain system will improve his job performance (Davis, 1989). The relationship between perceived benefits and satisfaction was studied by [6] in the context of mobile commerce and for the adoption of mobile banking by [7]. Empirical results prove that PU is one of the most important predictors of intention to use technology [8].



Consumer confirmation is comparing the performance level of a product or service with evaluative standards formed by expectations before their purchase, validating the decision to use [4]. People compare the expectations and performance before use, which is imagined as the actual performance expectation of M-wallet through various functions such as digital payments, secure information storage, the convenience of use, power efficiency, connectivity, integration with other relevant applications, operating system compatibility and usage rewards [9-10].

Satisfaction is a psychological concept of purchasing and using experiences [11]. The current study focuses on how users feel about all aspects of their experience, including the purchase experience and smart wearable.

#### *A. Confirmation on Perceived Usefulness*

Confirmation will increase the perception of usefulness while disconfirmation will reduce this perception [12]. In mobile instant research [13] said that confirmation has a positive effect on the perceived of usefulness. In the m-swallow adoption research conducted by [10] said that confirmation has a positive effect on perceived usefulness. So in this study applies confirmation of financial technology. Then the hypothesis made is:

**H1: Confirmation has a positive effect on Perceived Usefulness**

#### *B. Confirmation on Satisfaction*

Previous research has found that confirmation is positively related to satisfaction [4]. When the usage experience matches or exceeds initial expectations, there is a confirmation to lead to user satisfaction because of the expected benefits. In instant mobile research [13] said that confirmation has a positive effect on satisfaction. In the research on the adoption of m-swallow conducted by [10] said that confirmation has a positive effect on satisfaction. So in this study, this study applies confirmation of financial technology. Then the hypothesis made is:

**H2: Confirmation has a positive effect on Satisfaction**

#### *C. Perceived Usefulness on Satisfaction*

In ECM, post-consumption expectations are represented in terms of the perceived ex-post usability. Perceived usefulness is the user's perception of the expected benefits from using IS [14]. In the research on the adoption of m-swallow conducted by [10] said that Perceived usefulness has a positive effect on satisfaction, this research makes a hypothesis:

**H3: Perceived usefulness has a positive effect on Satisfaction.**

#### *D. Trust on Perceived Usefulness*

In marketplace research using Kaskus [15] reveals that trust is significantly perceived usefulness, which means that trust perceived usefulness can increase customer intention to buyback. Trust can increase consumer intention to buy back online. So in this study proposes the use of trust and perceived usefulness in the use of mobile payments. Then a hypothesis is proposed:

**H4: Trust has a positive effect on Perceived usefulness.**

#### *E. Trust on Satisfaction and Continuance intention to use*

When a user's satisfaction with smartphone banking increases, they will have a tendency to use the system again [4]. This level of satisfaction is influenced by the trust which is a consequence of post-adoption beliefs. Research [16] in e-banking revealed that Trust significantly influences user satisfaction and Trust significantly influences continuance use intention. Based on this the following hypothesis is made:

**H5: Trust has a positive effect on Satisfaction**

**H6: Trust has a positive effect on Continuance Intention to Use**

#### *F. Satisfaction on Continuance intention to use*

This study adopts the definition of satisfaction using mobile food apps proposed by [17] which defines customer satisfaction with respect to previous purchasing experiences with certain electronic commerce companies. "In line with this definition, the use of mobile apps matches or exceeds customer expectations, customers will more pleased with their experience related to the application of mobile apps. Thus, the following hypothesis proposes that:

**H6: Satisfaction has a positive effect on Continuance Intention to Use**

### **III. Methodology**

The methodology in this study uses statistical tests. The statistical test used is the SEM method and uses Smart PLS. In the SEM test, the first is to test the validity of the questionnaire data from 338 respondents.

Data collection from respondents is done using google form. There are 2 stages in this validity test, namely the convergent validity test, namely by looking at the outer loading value, and the discriminant validity test by looking at the Fornell Lacker value. The data is said to be convergent valid if the outer loading value of each indicator is above 0.7 and it is said to be discriminately valid if the Fornell Lacker value between the same variables is the highest value.

After the data is declared valid by testing its validity, then the reliability test is carried out by looking at the Cronbach's Alpha value and its AVE value. The data is said to be reliable if the Cronbach's Alpha value is above 0.7 and the AVE value is above 0.5.

Hypothesis test is the last test conducted for SEM PLS, namely by looking at the P value, using a test level of 5%, meaning that if the P value is below 0.05, then the hypothesis is accepted, if the P value is above 0.05 then the hypothesis is rejected.

#### IV. Data Analysis and discussion

##### A. Demographic of Respondents

Respondents used in this study were 338 people, with demographics can be seen in Table 1.

TABLE I. TABLE RESPONDENT DEMOGRAPHIC

Number of Respondents (n=338)		
<b>Long Time Using:</b>		
<= 6 months	18	5.33%
7 s/d 12 month	37	10.95%
>2,5 years	107	31.66%
1 s/d 1,5 years	1	0.30%
1,1 s/d 1,5 years	64	18.93%
1,6 s/d 2 years	75	22.19%
2,1 s/d 2,5 years	36	10.65%
<b>Income:</b>		
<= 3 million	127	37.57%
>11 million	41	12.13%
>9,1-11 million	1	0.30%
3,1-5 million	64	18.93%
5,1-7 million	60	17.75%
7,1-9 million	24	7.10%
9,1-11 million	21	6.21%
<b>Gender:</b>		
Female	147	43%
Male	191	57%
<b>Education:</b>		
Diploma	20	5.92%
Magister and Doctor	75	22.19%
Undergraduate	218	64.50%
<High School	25	7.40%
<b>Average Usage:</b>		
Several times a month	155	45.86%
Several times a day	15	4.44%
Several times a week	109	32.25%
Almost every day	59	17.46%

From Table 1, it can be seen that the duration of use is dominated by usage less than 2.5 years, namely as much as 31.66%. Meanwhile, the income of respondents is dominated by users who have an income of less than 3 million per month. For education level, it was dominated by respondents with undergraduate education as much as 64.50%. Meanwhile, the average usage is at most several times a month.

##### B. Validity Test

###### 1. Convergent validity

The convergence test of validity is by looking at the outer factor of the statistical test using Smart PLS as shown in Table 2.

TABLE II. OUTER LOADING FACTOR

CI1		0.906			
CI2		0.917			
CI3		0.870			
CI4		0.880			
COF1	0.801				

COF2	0.860				
COF3	0.901				
COF4	0.800				
PU1			0.893		
PU2			0.930		
PU3			0.829		
SAT1				0.909	
SAT2				0.915	
SAT3				0.934	
SAT4				0.893	
TRU1					0.867
TRU2					0.843
TRU3					0.855

From data Table 2, it can be seen that the value of the outer loading factor of all indicators is greater than 0.7, which means that the indicator is valid.

In addition to seeing outer loading, for convergence of this validity, the Average Variance Extracted (AVE) value must also be seen in Table 3.

TABLE III. AVE VALUE

Variable	Average Variance Extracted (AVE)
COF	0.708
CI	0.798
PU	0.783
SAT	0.833
TRU	0.731

Based on Table 3, the AVE value is above 0.5. By looking at the results from Table 2 and Table 3, it can be concluded that the data is convergent valid.

## 2. Discriminant Validity

A discriminant validity test is carried out by looking at Fornell Lacker criteria as in Table 4.

TABLE IV. FORNELL-LARCKER CRITERION

	COF	CI	PU	SAT	TRU
COF	0.841				
CI	0.637	0.893			
PU	0.571	0.547	0.885		
SAT	0.751	0.730	0.582	0.913	
TRU	0.655	0.734	0.513	0.825	0.855

Based on Table 4, it can be seen that between the same variables, for example, COF and COF have the highest value compared to other variables. This proves that this model meets the requirements of discriminant validity.

## C. Reliability Test

After the research model is declared valid data, the next step is to test the reliability. The reliability test was carried out by looking at the Cronbach Alpha value and also the composite reliability value as shown in Table 5.

TABLE V. THE VALUE CRONBACH'S ALPHA AND COMPOSITE RELIABILITY

Var	Cronbach's Alpha	Composite Reliability
COF	0.861	0.906
CI	0.916	0.941
PU	0.860	0.915
SAT	0.933	0.952
TRU	0.816	0.891

Table 5 shows that the values of Cronbach's Alpha and Composite reliability are both greater than 0.7 which means that the data in this model are reliable.

#### D. Hypothesis testing

The last step of this statistical test is to test the hypotheses that are made in the proposed model. Before being tested, the data was bootstraps 5000 times, so that the test results could be accounted for. This hypothesis test uses a two-tailed test with a p value of 5%, the results can be seen in Table 6.

TABLE VI. RESULT HYPOTHESIS TEST

	Original Sample (O)	Sample Mean (M)	T Statistics ( O/STDEV )	P Values	Hipotesa
COF -> PU	0.411	0.413	7,534	0.000	Accepted
COF -> SAT	0.323	0.324	7,542	0.000	Accepted
PU -> SAT	0.112	0.111	3,058	0.002	Accepted
SAT -> CI	0.388	0.388	5,961	0.000	Accepted
TRU -> CI	0.414	0.415	6,478	0.000	Accepted
TRU -> PU	0.244	0.244	4,406	0.000	Accepted
TRU -> SAT	0.556	0.556	13,392	0.000	Accepted

Based on table 6, the results of the hypothesis test show that the value of the P Value is below 5% or 0.05 for all Hypotheses, which means that all hypotheses compiled in the proposed research model are accepted.

As shown in Table VI, all hypotheses are supported. Table IV shows that all the hypotheses are accepted. The hypothesis in the hypothesis group is very strong with the original sample value (O) greater than 0.388 is satisfaction with Continuance Intention, Trust on Continuance Intention, Trust on Satisfaction, Confirmation on Perceived of Used. while the hypothesis in the moderate group with the original sample value (O) is greater than 0.112 is perceived of used to satisfaction, trust to perceived of used, confirmation of satisfaction.

#### V. Conclusion

This study aims to examine various factors that influence the sustainable adoption and use of mobile payments by Indonesian consumers. First, the researcher applies the expectation confirmation model (ECM) as the main theory and extends the model with the Trust construction to make it more relevant to consumers. Empirically test the ECM model among 338 respondents to identify a significant determinant of consumer usage behavior towards mobile payments.

The results reveal that the construction of trust is a significant determinant of the behavior of using mobile payments through Continuance Intention, Satisfaction, and Perceived of Use.

This research confirms that the mobile payment service provided is following what users expect. By using mobile payment, users can save time. Mobile Payment users believe and are satisfied with the service and users will continue to take advantage of the mobile payment service.

#### ACKNOWLEDGMENT

I would like to gratefully acknowledge the Directorate General of Higher Education, Ministry of Education and Culture, Republic of Indonesia, which provide research project including the support from Department of Information Systems, Soegijapranata Catholic University, Indonesia.

#### References

- [1] Wang, G., & Song, J. (2017). The relation of perceived benefits and organizational supports to user satisfaction with building information model (BIM). *Computers in Human Behavior*, 68, 493–500. <https://doi.org/10.1016/j.chb.2016.12.002>.
- [2] Alkhowaiter, W. A. (2020). Digital payment and banking adoption research in Gulf countries: A systematic literature review. *International Journal of Information Management*, 53(February), 102102. <https://doi.org/10.1016/j.ijinfomgt.2020.102102>
- [3] Kabra, G., Ramesh, A., Akhtar, P., & Dash, M. K. (2017). Understanding behavioral intention to use information technology: Insights from humanitarian practitioners. *Telematics and Informatics*, 34(7), 1250–1261. <https://doi.org/10.1016/j.tele.2017.05.010>

- [4] Bhattacherjee, A. (2011). Understanding Information Systems Continuance: An Expectation-Confirmation Model. *MIS Quarterly*, 25(3), 351–370.
- [5] Gerrard, P., & Barton Cunningham, J. (2003). The diffusion of Internet banking among Singapore consumers. *International Journal of Bank Marketing*, 21(1), 16–28. <https://doi.org/10.1108/02652320310457776>
- [6] Agrebi, S., & Jallais, J. (2015). Explain the intention to use smartphones for mobile shopping. *Journal of Retailing and Consumer Services*, 22, 16–23. <https://doi.org/10.1016/j.jretconser.2014.09.003>
- [7] Bankole, F. O., Bankole, O. O., & Brown, I. (2011). Mobile Banking Adoption in Nigeria. *The Electronic Journal of Information Systems in Developing Countries*, 47(1), 1–23. <https://doi.org/10.1002/j.1681-4835.2011.tb00330.x>
- [8] Natarajan, T., Balasubramanian, S. A., & Kasilingam, D. L. (2017). Understanding the intention to use mobile shopping applications and its influence on price sensitivity. *Journal of Retailing and Consumer Services*, 37(January), 8–22. <https://doi.org/10.1016/j.jretconser.2017.02.010>
- [9] Susanto, A., Chang, Y., & Ha, Y. (2016). Determinants of continuance intention to use the smartphone banking services: An extension to the expectation-confirmation model. *Industrial Management and Data Systems*, 116(3), 508–525. <https://doi.org/10.1108/IMDS-05-2015-0195>
- [10] Gupta, A., Yousof, A., & Mishra, A. (2020). How pre-adoption expectancies shape post-adoption continuance intentions: An extended expectation-confirmation model. *International Journal of Information Management*, 52(April 2019), 102094. <https://doi.org/10.1016/j.ijinfomgt.2020.102094>
- [11] Bhattacherjee, A., & Premkumar, G. (2012). Theoretical Model and Longitudinal Test Article in Belief and Changes Understanding Information Attitude Toward Technology A Theoretical Usage: Model and Longitudinal. *Management Information Systems*, 28(2), 229–254. <https://doi.org/10.2307/25148634>
- [12] Thong, J. Y. L., Hong, S. J., & Tam, K. Y. (2006). The effects of post-adoption beliefs on the expectation-confirmation model for information technology continuance. *International Journal of Human-Computer Studies*, 64(9), 799–810. <https://doi.org/10.1016/j.ijhcs.2006.05.001>
- [13] Oghuma, A. P., Libaque-Saenz, C. F., Wong, S. F., & Chang, Y. (2016). An expectation-confirmation model of continuance intention to use mobile instant messaging. *Telematics and Informatics*, 33(1), 34–47. <https://doi.org/10.1016/j.tele.2015.05.006>
- [14] Davis, F. D. (1989). Perceived usefulness, perceived ease of use, and user acceptance of information technology. *MIS Quarterly: Management Information Systems*, 13(3), 319–339. <https://doi.org/10.2307/249008>
- [15] Setyorini, R., & Nugraha, R. P. (2016). The Effect of Trust Towards Online Repurchase Intention With Perceived Usefulness As An Intervening Variable: A Study on KASKUS Marketplace Customers. *The Asian Journal of Technology Management*, 9(1), 1–7.
- [16] Liébana-Cabanillas, F., Muñoz-Leiva, F., & Rejón-Guardia, F. (2013). The determinants of satisfaction with e-banking. *Industrial Management and Data Systems*, 113(5), 750–767. <https://doi.org/10.1108/02635571311324188>
- [17] Alalwan, A. A. (2020). Mobile food ordering apps: An empirical study of the factors affecting customer e-satisfaction and continued intention to reuse. *International Journal of Information Management*, 50(April 2019), 28–44. <https://doi.org/10.1016/j.ijinfomgt.2019.04.008>

### XIII. Publikasi Jurnal Internasional

Rencana Publikasi pada jurnal internasional. Data paper dan jurnal internasional sebagai berikut:

Nama jurnal internasional:

Online Information Review

Judul paper:

An Investigation of the Acceptance of Online Entertainment Technologies in Indonesia

Penulis:

Bernardinus Harnadi, Albertus Dwiyoga Widianoro, FX. Hendra Prasetya.

Publisher:

Emarald

Paper yang dikirim ke Jurnal:

Abstract

**Purpose** - This research investigates acceptance of online entertainment technology based on the role of Habit as a mediator and Age, Gender, and Cultural factors as moderating variables on the acceptance.

**Design/methodology/approach** - The theoretical model was employed to examine the causal effect on acceptance as well as moderating effects of the factors. The theoretical model was tested with online entertainment consumers and evaluated using structural equation modeling and the results confirmed several findings and new findings which are not stated in previous researches.

**Findings** - The findings confirm the positive and direct effect of Behavioral Intention due to Habit and Price Value and Habit due to Hedonic Motivation and Social influence. New findings derived from moderating effect analysis show that Age, Individualism-Collectivism, and Feminism-Masculinity have moderating effects on Behavioral Intention due to Habit. Moreover, Gender and Uncertainty Avoidance have moderating effects on the Habit due to Hedonic Motivation.

**Originality/value** - This research contributes to not only the literature of online entertainment acceptance by integrating Habit as a mediator on the acceptance but also the literature concerning the hypothesis by composing evidence of Age, Gender, and Culture differences in the acceptance. Furthermore, this research serves practical insight into: parents and educators who need to know the characteristics of consumers of online entertainment; practitioners who need to know the segmentation and targeting regarding the differences of the consumers; and the online entertainment application developers regarding how to design the applications to satisfy the consumers of different ages, genders, and cultures.

**Keywords** - behavior, culture, habit, online entertainment technology, acceptance

**Paper type** Research paper

## 1. Introduction

According to Special Reports, Digital 2020 by Kemp [1], the total population of the world is 7.79 billion where 4.57 billion of them are internet users; and 5.15 billion of them are unique mobile phone users. Online entertainment is one of the most popular activities, especially during the Covid-19 pandemic. Kemp said that 7 in 10 mobile phone users had spent more time in their daily activities compared to the pre-pandemic levels. For example, there was an increase of 57 percent in watching streaming shows and movies, 47 percent in using social media, 46 percent in using messaging services, and 39 percent in streaming music services. The time spending on using social media and messaging services in the Y and Z generations were greater than the previous generation. In Indonesia, the number of internet users was 175.4 million in January 2020. It increases by 17 percent (25 million) compared to 2019. At the same time, the mobile connections were 338.2 million, and the connections increased by 4.6 percent (15 million) compared to 2019 [2]. The Y and Z generations as digital natives have a greater tendency to use technology because they have been familiar with these technologies in their daily lives since childhood. Their adaptation and instincts grow faster to adapt to the various things related to technology naturally (Sorgo, 2016). With an extensive of young people accept online technology especially online entertainment technology, the research on acceptance of the technology associating with gender and age differences has become even more important for technology developers and their consumers (Chawla, 2020; Chen, 2018; Harnadi, 2017; Wang and Sun, 2016; Lee, 2009; Akbar, F., 2013; Venkatesh et al. 2012; Venkatesh et al. 2003). Moreover, the researches on cultural differences on the acceptance of the technology were still limited (Tarhini et al., 2016; Alshare and Mousa, 2014), with the result that the consumers' and developers' insight on this problem are limited too. The research needs to be done to fulfill this gap.

The purpose of this research is to investigate the acceptance of online entertainment technology in Indonesia by examining variables related to the acceptance of online music, online gaming, video streaming, online comics, and online news. The research addresses these two research questions: First, which factors influence an individual's intention to accept online entertainment in Indonesia? Second, which relationships represent significant causal effects and which represent significant moderation effects on the intention? The questions lead to investigate the role of age, gender, and cultural factors on the acceptance of online entertainment technology.

The research model is proposed and questionnaires data was collected from a sample of 1121 individuals aged 14 – 24 years from three cities in Indonesia to be analyzed to gain the findings. The related literature regarding online entertainment studies comes from gaming studies (Chen, 2018; Harnadi, 2017; Merikivi, 2017; Wang and Sun, 2016; Wei and Lu, 2014; Fan et al., 2012; Lee, 2009). The other literature comes from e-commerce studies (Baabdullah et al., 2019; Khatimah, et al., 2019; Chopdar et al., 2018; Alalwan et al., 2018) and technology acceptance studies (Tarhini et al., 2016; Alshare & Mousa, 2014; Akbar, F., 2013; Venkatesh et al., 2012; Venkatesh et al., 2003).

There were limited researches conducted on moderating the effect of culture on acceptance of technology (Tarhini et al., 2016; Alshare and Mousa, 2014; Straub, 1997). Straub (1997) conducted research that employed cultural factors naming Power Distance, Individualism, Feminism, and Uncertainty Avoidance as moderator variables. Meanwhile, Tarhini et al. (2016) employed Power Distance, Feminism, and Uncertainty Avoidance and Alshare & Mousa (2014) only employed Power Distance and Individualism as moderator variables. The related literature on e-commerce and organization contexts conducting Habit as

a predictor on Behavioral Intention also limited such as research conducted by Khatimah, et al. (2019), Chopdar et al. (2018), and Venkatesh et al. (2012).

Drawing upon the selectivity hypothesis, which argues that hedonic motivation and social interaction of customers drives the individual' habit in using online entertainment (Khatimah, et al., 2019) and the habit establishes the acceptance of online entertainment (Khatimah, et al., 2019; Chopdar et al., 2018; Venkatesh et al., 2012), we propose that hedonic motivation and social influence can drive the individual' habit and then accept online entertainment. Furthermore, the hypothesis argues that male and female consumers have different habits and hedonic motivations regarding their acceptance (Venkatesh et al., 2012). The hypothesis also argues that young and adult consumers have a different mode of habit in their acceptance (Venkatesh et al., 2012). Eventually, we propose consumers of different gender and age will respond to different habits and acceptance in using online entertainment. Moreover, consumers of different ages respond to the different hedonic motivations in using online entertainment. Furthermore, we propose consumers with different culture naming Power Distance, Individualism, Feminism, and Uncertainty Avoidance will respond to different perception in using online entertainment.

To test the related hypothesis, we conduct a study on the causal effect of Habit and other factors related to previous research including Hedonic Motivation, Price Value, and Social Influence on Behavioral Intention to use online entertainment technology and also investigate the role of age, gender and cultural factors as a moderator on Habit and Behavioral Intention. The findings of the research regarding full or partial support for the hypotheses are derived from previous studies. Consequently, the finding has not highlighted any new findings related to direct causal effects on Behavioral Intention. New Findings regarding the role of age, gender, and culture on the individual's habit and intention to accept online entertainment are gained from moderation analysis on the Habit and Behavioral Intention. New findings contribute to not only the existing online entertainment literature by incorporating the moderating role of age, gender, and culture in accepting online entertainment, but also the literature relating the selectivity hypothesis by delivering evidence of age, gender, and cultural differences in acceptance of online entertainment. Besides, the practical implication of the new findings associated with the moderating effects of Age, Gender, and Culture offers marketing managers and developers practical insight into how to design attractive online entertainment applications to gratify consumers of different ages, gender, and culture.

This paper begins with a review of related literature in Section 2, we review the related literature on Behavioral Intention in the context of online entertainment technology, e-commerce technology, and technology acceptance in general and on moderating effect of age, gender, and culture. This is followed by a proposed theoretical model and hypotheses in Section 3. Section 4 presents the research methodology. We perform data analysis and results in Section 5. Section 6 discuss the findings and new findings and conclude with implication, limitations, and possible further work. The last, Section 7 presents the conclusion of this research.

## 2. Overview of Literatures

### 2.1 Research Variables<sup>[RN1]</sup>

The variables utilized in this research are presented in Table 1 providing the operational definition of the variables in this research.

**Table 1. Operational definition of research variables**

Variables	Operational Definitions	Reference
Hedonic motivation	The extent to which an individual perceives that playing online media entertain is fun or pleasure.	Venkatesh et al. (2012)
Habit	The extent to which people tend to perform behaviors automatically because of learning and their behaviors was the result of prior experiences.	Venkatesh et al. (2012)
Social Influence	The degree to which an individual perceives that important others believe that they should use the system.	Venkatesh et al. (2003)
Price Value	The extent to which 'consumers' cognitive tradeoff between the perceived benefits of the applications and the monetary cost for using them.	Venkatesh et al. (2012)
Behavioral Intention	The extent to which the user intends to play online entertainment in the future.	Harnadi (2017)
Gender	The individual's gender is measured as male or female.	Nil
Age	The individual's age in years.	Nil
Power Distance	The extent to which individuals expect and accept differences	Tarhini et al. (2016)

Variables	Operational Definitions	Reference
	in power between different people.	
Individualism-Collectivism	The extent to which individuals are integrated into groups.	Tarhini et al. (2016)
Feminism-Masculinity	The extent to which traditional gender roles are differentiated.	Tarhini et al. (2016)
Uncertainty Avoidance	The extent to which ambiguities and uncertainties are tolerated.	Tarhini et al. (2016)

The reviews of related researches on related researches on online entertainment, e-commerce, and technology acceptance are displayed in Table 2.

**Table 2. Previous Researches of Behavioral Intention (BI) in the context of online entertainment, e-commerce, and acceptance of technology**

Model/Theory	Causal Effects on BI	Moderating Effects	Data Collection	Reference
<b>Research in the Context of Online Entertainment</b>				
U & G Expectancy model in mobile English learning games acceptance	Gratification	<b>Gender</b> as a moderator of the effect of Gratification on Continue Intention	Quantitative survey	Chen (2018)
Extended UTAUT model in online gaming acceptance	Perceived Enjoyment, Performance Expectancy, Facilitating Conditions	<b>Age</b> as a moderator of the effect of Effort Expectancy on BI. <b>Gender</b> as a moderator of the effect of Performance Expectancy on BI	Quantitative survey	Harnadi (2017)
ETAM in digital game acceptance of the elderly	Game Narrative, Social Interaction, Physical Condition, Perceived Ease of Use, Attitude	<b>Age</b> as a moderator of the effect of Perceived Ease of Use on BI. <b>Gender</b> as a moderator of the effect of Perceived Ease of Use on BI. <b>Experience</b> as moderator of the effect of Perceived Ease of Use and Attitude on Intention	Quantitative survey	Wang and Sun (2016)
Investigating factors that influence people to play mobile social games	Enjoyment, Interaction with others, perceived number of users, perceived number of peers, Time flexibility	None	Quantitative web survey	Wei and Lu (2014)
Antecedents of users' intentions to play online games using TAM and TPB	Flow, Subjective norm, Perceived usefulness, Perceived ease of use	None	Quantitative survey	Fan et al. (2012)
Examining two competing models based on TPB and TAM	Flow Experience, Perceived Enjoyment, Attitude, Subjective Norms, Perceived Behavioral Control	<b>Gender</b> as a moderator of the effect of Perceived Enjoyment on BI, Attitude on BI, human-computer interaction to flow experience. <b>Experience</b> as moderator of the effect of Perceived Behavioral Control on BI	Quantitative web survey	Lee (2009)
<b>Research in the Context of E-commerce Technology</b>				
The role of age and gender in consumer mobile banking use	Performance Expectancy, Effort Expectancy, Price Value, Perceived Security, Facilitating Conditions, Trust	<b>Age</b> as a moderator of the effect of Habit, Hedonic Motivation, Price Value on BI. <b>Gender</b> as a moderator of the effect of Price Value on BI.	Quantitative survey	Merhi et al. (2020)
Investigating consumer use of	Performance Expectancy, Facilitating Conditions,	None	Quantitative survey	Baabdullah et al. (2019)



Model/Theory	Causal Effects on BI	Moderating Effects	Data Collection	Reference
mobile banking	Hedonic Motivation, Price Value, Habit, Service Quality, System Quality			
The role of payment habit as a mediator on user acceptance of e-money	Habit	None	Quantitative survey	Khatimah et al. (2019)
Investigating factors predicting mobile shopping acceptance	Performance Expectancy, Effort Expectancy, Facilitating Conditions, Hedonic Motivation, Price Value, Habit, Privacy Risk	None	Quantitative survey	Chopdar et al. (2018)
Examining factors influencing acceptance of mobile banking	Perceived Risk, Hedonic Motivation, Price Value, Performance Expectancy, Effort Expectancy	None	Quantitative survey	Alalwan et al. (2018)
<b>Research in the Context of Acceptance of Technology</b>				
Moderating effect of individual-level culture values on the user's acceptance of E-learning	Perceived Ease of Use, Perceived Usefulness, Subjective Norms, Quality of Work Life	<b>Power Distance</b> as moderator of the effect of Subjective Norms on BI, Perceived Usefulness on BI. <b>Individualism</b> as moderator of the effect of Subjective Norms on BI. <b>Uncertainty Avoidance</b> as moderator of the effect of Subjective Norms on BI	Quantitative survey	Tarhini et al. (2016)
Moderating effect of Espoused Cultural Dimensions on Consumer's acceptance to use the mobile payment device	Performance Expectancy, Social Influence, Perceived Information Security	<b>Collectivism</b> as moderator of the effect of Social Influence on BI. <b>Uncertainty Avoidance</b> as moderator of the effect of Effort Expectancy on Performance Expectancy and Perceived Information Security on BI. <b>Masculinity</b> as moderator of the effect of Performance Expectancy on BI	Quantitative survey	Alshare & Mousa (2014)
Students' acceptance and use of technology in an academic environment	Performance Expectancy, Attitude	<b>Age</b> as a moderator of the effect of Performance Expectancy, Effort Expectancy, and Social Influence on BI. <b>Gender</b> as a moderator of the effect of Performance Expectancy, and Effort Expectancy on BI. <b>Experience</b> as a moderator of the effect of Perceived Ease of Use and Attitude on Intention	Quantitative survey	Akbar, F. (2013)
Investigating consumer acceptance and use of technology based on Extended UTAUT model	Performance Expectancy, Effort Expectancy, Social Influence, Facilitating Conditions, Hedonic Motivation, Price Value, Habit	<b>Age</b> as a moderator of the effect of Performance Expectancy, Effort Expectancy, Social Influence, Facilitating Conditions, Hedonic Motivation, Price Value, and Habit on BI. <b>Gender</b> as a moderator of the	Quantitative survey	Venkatesh et al. (2012)

Model/Theory	Causal Effects on BI	Moderating Effects	Data Collection	Reference
		effect of Performance Expectancy, Effort Expectancy, Social Influence, Facilitating Conditions, Hedonic Motivation, Price Value, and Habit on BI. <b>Experience</b> as a moderator of the effect of Effort Expectancy, Social Influence, Hedonic Motivation, and Habit on BI.		
UTAUT model	Performance Expectancy, Effort Expectancy, Social Influence	<b>Age</b> as a moderator of the effect of Performance Expectancy, Effort Expectancy, and Social Influence on BI. <b>Gender</b> as a moderator of the effect of Performance Expectancy, Effort Expectancy, and Social Influence on BI. <b>Experience</b> as a moderator of the effect of Effort Expectancy and Social Influence on BI	Quantitative survey	Venkatesh et al. (2003)

According to data in Table 2, almost all of the research of behavioral intention in the context of online entertainment, e-commerce, or technology acceptance propose a theoretical model with hypotheses were examined using quantitative data collected using a questionnaire. The several models in TAM, TPB, Extended-TAM, UTAUT, and Extended-UTAUT are used extensively. However, there are a few research that investigates moderating effects and specifically, none of these have been conducted in Indonesia.

## 2.2 Hedonic Motivation, Habit, and Behavioral Intention

Hedonic Motivation is an interesting factor in acceptance research, which divides into Perceived Enjoyment (PE) and Flow Experience (FE). On the research of acceptance to use technology, Harnadi (2017), Wei and Lu (2014), Luo et al. (2011), Koo (2009) and Lee (2009) employed PE and Harnadi (2017), Fan et al. (2012), and Koo (2009) employed FE as predictors on Behavioral Intention (BI). PE also acted as a predictor on Use Behavior according to Merikivi (2017), meanwhile, Luo et al. (2011) employed Entertainment as a predictor on Use Behavior. Venkatesh et al. (2012) employed Hedonic Motivation as a predictor on BI.

According to Harnadi (2017), Koo (2009), and Lee (2009), PE has a statistically significant direct effect on BI. Luo et al. (2011) conducted a study on information service adoption and they derived the result that PE has also a statistically significant direct effect on Attitude and Attitude on BI. In the relation of FE and BI, several types of research resulted in the analysis where FE has a statistically significant direct effect on BI according to Fan et al. (2012) and Koo (2009). Moreover, Koo (2009) employed Escape, and Harnadi (2017) concluded in his study that FE has a partially significant direct effect on BI.

Research employing Hedonic Motivation as a predictor on Habit conducted by Khatimah, et al. (2019). The research also employed Social Influence as a predictor of Habit. It resulted in the Hedonic Motivation and Social Influence have a statistically significant direct effect on Habit.

Habit is also an interesting factor in the acceptance to use e-commerce technology and to use technology in general. Khatimah, et al. (2019), Chopdar et al. (2018), and Venkatesh et al. (2012) employed Habit as the predictor on Behavioral Intention, and Baabdullah et al. (2019) and Venkatesh et al. (2012) employed Habit as the predictor on Use Behavior. The result stated that Habit has a statistically significant direct effect on BI (Khatimah, et al., 2019; Chopdar et al., 2018; Venkatesh et al., 2012) and has a statistically significant direct effect on Use Behavior (Baabdullah et al., 2019; Venkatesh et al., 2012). Based on these reviews, we propose that:

H1: Hedonic Motivation has a statistically significant direct effect on Behavioral Intention to use online entertainment.

H2: Hedonic Motivation has a statistically significant direct effect on Habit.

H3: Habit has a statistically significant direct effect on Behavioral Intention to use online entertainment.

### 2.3 Social Influence and Behavioral Intention

The results from researches conducted by Harnadi (2017), Wang and Sun (2016), Fan et al. (2012), Koo (2009), and Lee (2009) employed Social Norm, Social Interaction, and Social Affiliation as a predictor of BI. While other researchers Harnadi (2017) and Venkatesh et al. (2012) use Social Influence as the predictor of BI. Social Interaction and Social Affiliation are factors having close naming to Social Influence. To further elaborate, researches conducted by Wang and Sun (2016), Fan et al. (2012), Venkatesh et al. (2012), Koo (2009), and Lee (2009) concluded that Social Influence has a statistically significant direct effect on BI. Other researchers Harnadi (2017) and Akbar (2013) stated that Social Influence has a partially statistically significant direct effect on BI.

As a reference Khatimah, et al. (2019) stated previously, that concurrently with Hedonic Motivation, Social Influence has a statistically significant direct effect on Habit. Based on these reviews, we propose that:

H4: Social Influence has a statistically direct effect on Behavioral Intention to use online entertainment.

H5: Social Influence has a statistically direct effect on Habit.

### 2.4 Price Value and Behavioral Intention

Price Value (PV) is an interesting factor in the acceptance of e-commerce research. According to Chopdar et al. (2018), Alalwan et al. (2018), and Venkatesh et al., (2012), PV has a statistically significant direct effect on BI. Other research conducted by Baabdullah et al. (2019) also stated that PV has a statistically significant direct effect on Use Behavior. Based on these reviews, we propose that:

H6: Price Value has a statistically direct effect on Behavioral Intention to use online entertainment.

### 2.5 Moderating Effect of Gender

Gender is employed as a moderator on the relations of factors on the acceptance technology model. Works by Merhi et al. (2020), Chen (2018), Harnadi (2017), Wang & Sun (2016), Venkatesh et al. (2012), Lee (2009), Wang & Wang (2008), Venkatesh et al. (2003) examine gender as a moderating factor on online gaming acceptance and consumer acceptance researches. Table 5 summarizes the moderating effect of gender on the related research which, regarding the relation of Hedonic motivation on Behavioral Intention, Venkatesh et al. (2012) and Lee (2009) state that the hedonic motivation has a stronger effect on males compared to the females. Another researcher, Wang & Wang (2008) did similar research and concludes that the effect of gender does not differ between males and females.

Two researchers, Lee (2009) and Venkatesh et al. (2003) present a different result on Gender as a moderator on the relation of social influence on Behavioral Intention. Venkatesh et al. (2003) state that the stronger effect was in females than males; Meanwhile, Lee (2009) concludes that Gender was not a significant moderator. Furthermore, Merhi et al. (2020) and Venkatesh (2012) use Gender as a moderator on the relation of Price Value and Habit on Behavioral Intention which resulting in a conclusion that Gender was a significant moderator on Price Value on Behavioral Intention with a stronger effect in females than males. Gender is also considered as a significant moderator on Habit and Behavioral Intention with a stronger effect in males than females.

**Table 3. Moderating effects of Gender**

Causal effect on BI	Moderator	Reference	Context of the Study
Hedonic Motivation	The stronger effect on males than on the female (Perceived enjoyment)	Lee (2009)	Online gaming
	The stronger effect on males than on the female	Venkatesh et al. (2012)	Consumer Acceptance and Use of technology
	The effect did not differ among male and female (Perceived enjoyment)	Wang and Wang (2008)	Online gaming
	Gender was not a significant moderator (Flow experience)	Lee (2009)	Online gaming
Social influence	The stronger effect on females than on the male.	Venkatesh et al. (2003)	Technology acceptance

Causal effect on BI	Moderator	Reference	Context of the Study
	Female was a significant moderator but not for males	Harnadi (2017)	
	Gender was not a significant moderator	Lee (2009)	Online gaming
Price value	The stronger effect on females than on the male.	Merhi et al. (2020)	Consumer mobile banking use
	The stronger effect on females than on the male.	Venkatesh et al. (2012)	Acceptance of mobile internet technology
Habit	The stronger effect on males than on the female.	Venkatesh et al. (2012)	Consumer Acceptance and Use of technology

## 2.6 Moderating Effect of Age

The works by Merhi et al. (2020), Harnadi (2017), Wang & Sun (2016), Akbar (2013), Venkatesh et al. (2012), Lee (2009), and Venkatesh et al. (2003) study the moderating of Age on the relation of factors on Behavioral Intention, summarized in Table 6. Venkatesh (2012) and Lee (2009) use Age as a moderator on the relation of Hedonic Motivation on Behavioral Intention and they came to a different conclusion. Merhi et al. (2020) and Venkatesh et al. (2012) conclude that Age was a significant moderator with a stronger effect on younger people than on older people, while Lee (2009) finds that Age was not a significant moderator.

Akbar (2013), Lee (2009), and Venkatesh et al. (2003) had studied the moderating effect of Age in the relation of Social Influence on Behavioral Intention, in which all of them have different results. Venkatesh (2003) finds that the effect is stronger on older people than on younger people, compared to Akbar's (2013) where the effect is stronger on younger people than older people. This differs from the research conducted by Lee (2009), which concludes that the effect of Age was not significant. Merhi et al. (2020) and Venkatesh et al. (2012) use Age as the moderator on the relation Price Value and Habit on Behavioral Intention and they came to a different conclusion. Merhi et al. (2020) conclude that Age was a significant moderator with a stronger effect on younger people than on older people, while Venkatesh et al. (2012) finds that a stronger effect was in older people than in younger people.

**Table 4. Moderating effects of Age**

Causal effect on BI	Moderator	Reference	Context of the Study
Hedonic Motivation	The stronger effect in younger people than in older people.	Merhi et al. (2020)	Consumer mobile banking use
	The stronger effect in younger people than in older people.	Venkatesh et al. (2012)	Consumer Acceptance and Use of technology
	Age was not a significant moderator	Lee (2009)	Online gaming
Social Influence	The stronger effect in older people than in younger people.	Venkatesh et al. (2003)	Technology acceptance
	The stronger effect in younger people than in older people.	Akbar (2013)	Technology acceptance on the academic environment
	Age was not a significant moderator	Lee (2009)	Online gaming
Price Value	The stronger effect in younger people than in older people.	Merhi et al. (2020)	Consumer mobile banking use
	The stronger effect in older people than in younger people.	Venkatesh et al. (2012)	Consumer Acceptance and Use of technology
Habit	The stronger effect in younger people than in older people.	Merhi et al. (2020)	Consumer mobile banking use
	The stronger effect in older people than in younger people.	Venkatesh et al. (2012)	Consumer Acceptance and Use of technology

## 2.7 Moderating Effect of Culture

According to Straub (1997), there are four culture dimensions used to examine their impact on technology acceptance known Hofstede's cultural dimensions which comprise Power Distance (PD), Individualism-

Collectivisms (I-C), Femininity-Masculinity (F-M), and Uncertainty Avoidance (AU). The cultural researches of this technology acceptance come from the e-learning context by Tarhini et al. (2016) and mobile payment device context by Alshare & Mousa (2014) where the four dimensions were employed as a moderator on the relation of factors on Behavioral Intention. Table 7 summarizes This moderating effect of culture on the related researches in which Tarhini et al. (2016) state that PD was a significant moderator on the relation of Performance Expectancy and Social influence on Behavioral Intention; I-C was a significant moderator on the relation of Effort Expectancy on behavioral Intention; both F-M and I-C were significant moderators on the relation of Performance Expectancy and Effort Expectancy. Meanwhile, Alshare & Mousa (2014) states that PD and I-C were significant moderators on the relation of Social Influence on Behavioral Intention and F-M was a significant moderator on the relation of Performance Expectancy on Behavioral Intention.

**Table 5. Moderating effects of Culture**

Causal effect on BI	Moderator	Reference	Context of the Study
<b>Moderating effects of Power Distance</b>			
Social influence	The stronger effect in Larger PD than in Smaller PD	Tarhini et al. (2016)	E-Learning
	PD was not a significant moderator	Alshare and Mousa (2014)	Mobile Payment Device
<b>Moderating effects of Individualism</b>			
Social influence	The stronger effect in Collectivism than in Individualism	Alshare and Mousa (2014)	Mobile Payment Device
<b>Moderating effects of Masculinity</b>			
Social influence on behavioral intention	The stronger effect in Femininity than in Masculinity	Tarhini et al. (2016)	E-Learning
<b>Moderating effects of Uncertainty Avoidance</b>			
Social influence	The stronger effect in Higher UA than in Lower UA	Tarhini et al. (2016)	E-Learning

On the moderating effects of PD on the relation of Social Influence on Behavioral Intention, Tarhini et al. (2016) and Alshare and Mousa (2014) each have a different result. According to Tarhini et al. (2016), PD is a significant moderator that has a stronger effect in higher PD than in lower PD. Meanwhile, Alshare and Mousa (2014) state that PD was not a significant moderator. Alshare & Mousa (2014) also investigates the mobile payment devices that resulted in I-C as a significant moderator on the relation of Social Influence on Behavioral Intention where its effect is stronger in Collectivism than Individualism. Tarhini et al. (2016) examine the moderating effects of F-M on the relation of Social Influence on Behavioral Intention; the result is that the stronger effect was in Femininity than Masculinity. To complete the results, Tarhini et al. (2016) examine AU as a moderating effect of Social Influence on Behavioral Intention; it concludes in the finding that higher UA is affected stronger than UA.

### 3. Proposed Theoretical Model and Hypotheses

Figure 1 presents the proposed theoretical model derived from the findings in previous studies. The causes and effects in the model are associated with research hypotheses and the measurement of variables is discussed in this section.

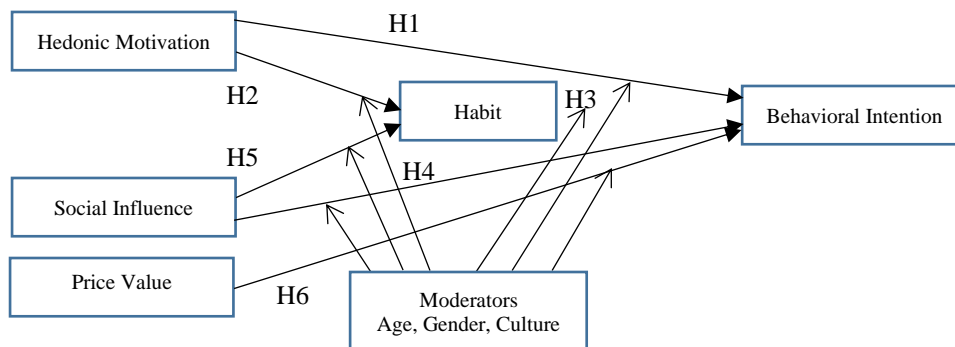

Figure 1. Proposed Theoretical Model

#### 4. Research methodology

Based on the theoretical model explained in the previous section, it is possible to build a questionnaire within two parts. The first part is used to collect demographic data of the respondents, including gender, age, and experience. The second is to capture the respondent's perception of the five latent variables on the model that are Hedonic Motivation, Social Influence, Habit, Price Value, and Behavioral Intention and four cultural factors naming Power Distance, Individualism, Masculinity, and Uncertainty Avoidance. Ten high schools and university students representing the Y and Z generation are tested respectively with the questionnaire to get improvement suggestions. The questionnaire was spread to three cities in Indonesia: Jakarta, Bali, and Semarang; the cities where the hard and soft questionnaires with printed paper and Google form respectively are spread. Additional questionnaires were also spread out to the researcher's contacts in two regions: Kalimantan and Sumatra Island via Google form.

Respondents returned 1163 questionnaires in which will be entered and processed into SPSS. Among the 1163 questionnaires, twenty-one needs to be eliminated because of the missing values, and ten more questionnaires were eliminated because of their out-of-range values. Furthermore, eleven questionnaires were removed as they have an outlier measure for the model variables. Consequently, 1121 questionnaires were the final sample size to be analyzed using SEM to ensure statistical validity and reliability, and other techniques were applied in the analysis and development of the proposed theoretical model.

#### 5. Data analysis and results

##### 5.1 Descriptive Data Analysis

Tables 8, 9, 10, and 11 present the demographic and behavioral factors of respondents. Table 8 shows most of the respondents (41.6 percent) come from the city of Bali and the remaining respondents come from cities Semarang and Jakarta and two island areas Kalimantan and Sumatera. They usually use video streaming (50.9 percent) as their online entertainment application, be followed by online music (22.4 percent) and online gaming (17.8 percent), and the remaining respondents (8.9 percent) use online comics and online news.

The demographic of Respondent in Table 9 shows that most of them are in the range of 15-19 years old or Z Generation (82.5 percent). From the Table, it is seen that most of the respondents (55 percent) were females. The majority of respondents (72.3 percent) have completed high school as their highest level of education or they are currently enrolled at high school. The remaining respondents have either completed a bachelor's degree or are currently registered for a bachelor's degree with other respondents who have either completed or are currently registered for a master's degree.

**Table 8. Regions and Cities of Respondent and applications they frequently use**

City	Freq.	%	Online Application	Freq.	%
Semarang	373	33.3	Online Music	251	22.4
Bali	466	41.6	Online Gaming	199	17.8
Jakarta	204	18.2	Video Streaming	571	50.9
Sumatera	13	1.2	Online Comic	53	4.7
Kalimantan	65	5.8	Online News	47	4.2
Total	1121	100.0	Total	1121	100.0

In this research, Age is employed as a moderating effect on each of the three causal effects of Hedonic Motivation, Social Influence, Price Value, and Habit on Behavioral Intention and two causal effects of Hedonic and Social Influence on Habit. Consequently, to analyze these moderating effects the participants are divided into two age groups: (a) Y generation, those of age older than 19 years (82.5 percent); and (b) Z generation, those of age 19 years or less (17.5 percent).

**Table 9. Age, Gender, Education, and Generation of Respondent**

Age	Freq.	%	Gender	Freq.	%
15	234	20.9	Male	504	45.0
16	293	26.1	Female	617	55.0
17	265	23.6	Total	1121	100.0
18	55	4.9	Generation	Freq.	%
19	78	7.0	Z	925	82.5
20	69	6.2	Y	196	17.5
21	57	5.1	Total	1121	100.0

22	28	2.5	<b>Education</b>	<b>Freq.</b>	<b>%</b>
23	22	2.0	High School	810	72.3
24	20	1.8	College	291	26.0
Total	1121	100.0	others	20	1.8
			Total	1121	100.0

According to data presented in Table 10, the mobile phone is the most popular device (90.7 percent) to access online entertainment and most of them access it from home (93 percent) than other places like school/college and net cafe.

**Table 10. Location and devices frequently used by Respondent**

Devices	Freq.	%	Location	Freq.	%
Mobile Phones/Tablets	1017	90.7	Home	1042	93.0
Laptop/PC	96	8.6	School/College	67	6.0
Console	8	.7	Net Café	12	1.1
Total	1121	100.0	Total	1121	100.0

These behavioral factors regarding experience and the time respondents spent using online entertainment are shown in Table 11. Most of them have experience using online entertainment for over three years (75.6 percent), and on average, using it five times a week (80.9) and over three hours daily (40.7 percent).

**Table 11. Behavioral Factor, Experience, and Time Respondents spent using online media entertain**

Experience	Freq.	%	Day/Week	Freq.	%	Hour/Day	Freq.	%
<= 6 months	26	2.3	once a week	43	3.8	< 30 minutes	46	4.1
6 - 12 months	28	2.5	twice a week	34	3.0	30 - 60 minutes	166	14.8
1 - 1.5 years	51	4.5	three a week	74	6.6	1 - 2 hours	234	20.9
1.6 - 2 years	32	2.9	four times a week	63	5.6	2 - 3 hours	219	19.5
2.1 - 2.5 years	51	4.5	five times a week	907	80.9	> 3 hours	456	40.7
2.5 - 3 years	86	7.7	Total	1121	100.0	Total	1121	100.0
>= 3 years	847	75.6						
Total	1121	100.0						

## 5.2 Data Analysis

The theoretical model using construct Validity of measure for the latent variables was examined using Principal Component Factor analysis, while Cronbach's Alpha Coefficient measures the equivalent reliability of indicators. Table 12 shows the result of validity and reliability, which shows that all indicators are satisfactory construct validity with factor loadings of magnitude greater than 0.4 and has eigenvalues greater than 1. All indicators on the latent variable prove to be acceptable, good, and excellent as shown in table 12.

**Table 12. Construct Validity and Equivalent Reliability of indicators**

	HB-BI	HM	SI	PV	Cronbach's Alpha
HB1	.590	.343	.085	.225	.726
HB2	.661	.224	.146	.136	Acceptable
HB3	.649	.120	.133	-.095	
BI1	.771	.180	.180	.270	
BI2	.806	.136	.127	.259	Excellent
BI3	.772	.161	.187	.274	
HM1	.162	.831	.161	.134	
HM2	.142	.818	.218	.105	Good
HM3	.166	.840	.103	.148	
SI1	.118	.197	.853	.104	
SI2	.062	.155	.879	.141	Good
SI3	.193	.091	.693	.259	
PV1	.087	.233	.155	.716	
PV2	.063	.078	.193	.820	Acceptable

PV3	.215	.082	.141	.786	
-----	------	------	------	------	--

Table 13 shows the correlation coefficient among variables in the theoretical model. This coefficient was used to assign the profile of respondents and variables in the model. Table 13 states that:

1. A significant positive correlation ( $p < 0.05$ ) among variables was found on Experience, Hour/Day, Hedonic Motivation, Social Influence, Price Value, Habit, and Behavioral Intentions. It means that the high/low variables correlate with the high/low variables they associated.
2. Age only positively correlates ( $p < 0.05$ ) to Education, Social Influence, Price Value, and Behavioral Intentions. Meanwhile, Education has a significant negative correlation to Experience and a significant positive correlation to Social Influence.
3. All relations in the theoretical model to be a significant positive correlation on variables employed on it.

**Table 13. Correlation coefficient among variables**

	A										
A	1	Edu									
Edu	.812**	1	Exp								
Exp	-.037	-.087**	1	D/W							
D/W	-.022	-.021	.244**	1	H/D						
H/D	-.050	-.027	.282**	.335**	1	HM					
HM	.021	-.006	.092**	.071*	.213**	1	SI				
SI	.104**	.062*	.059*	.026	.118**	.396**	1	PV			
PV	.109**	.031	.106**	.042	.119**	.348**	.419**	1	HB		
HB	.018	-.004	.115**	.130**	.295**	.408**	.325**	.334**	1	BI	
BI	.088**	.045	.169**	.168**	.302**	.413**	.379**	.425**	.587**	1	

\*\* . Correlation is significant at the 0.01 level (2-tailed).

\* . Correlation is significant at the 0.05 level (2-tailed).

### 5.3 Causal Effect Analysis

The causal effect analysis was done by AMOS software, and Figure 1 shows its result of the SEM analysis as presented on the following format:

1. The first thing shown is the data with unstandardized effect, followed by its statistical significance using \*, \*\*, and \*\*\* to express its significance at a level of 0.05, 0.01, and 0.001, respectively. NS indicates the data is not significant statistically at a level of 0.05 or less; and
2. In the parentheses, data with the standardized effect is shown first, followed by the interpretation of its magnitude as Cohen (1988) described, small (S), medium (M), or large (L) with magnitude less than 0.1, 0.1 to less than 0.5, and 0.5 or greater respectively

Figure 1 shows two effects on Behavioral Intention Hedonic due to Motivation and Social Influence are positive, small, but not statistically significant at the level of 0.005 or less. Conversely, the two effects on Habit due to Hedonic Motivation and Social Influence have a positive, medium, and statistically significant. The other two effects on Behavioral Intention due to Habit and Price Value also have a positive, large, and statistically significant and positive, medium, and statistically significant, respectively. The fit statistic for the theoretical model was shown in Table 14. From the table, the theoretical model has fit statistics that are very satisfactory, as suggested by Kline (2005). The satisfactory proportion of the variance in Behavioral Intention ( $R^2 = 56$  percent) and Habit ( $R^2 = 34$  percent) are explained by the three and two exogenous variables that affect it, respectively.

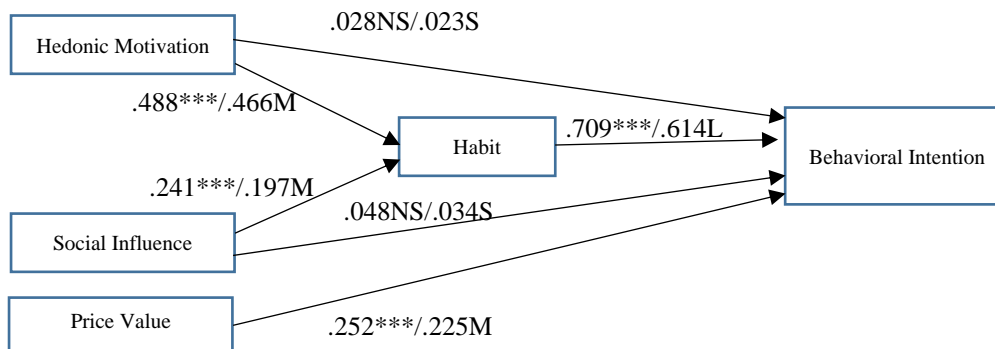

a) \*\*\* means  $p < 0.001$  and NS means not statistically significant at 0.05 level or less



b) S (Small), M (Medium), L (Large) standardized effects are those with magnitudes less than 0.1, 0.1 to less than 0.5, and equal to and more than 0.5, respectively.

Figure 2. Direct effects in the theoretical model

**Table 14. Fit statistics for the theoretical model**

Model	N	NC ( $\chi^2/df$ )	RMR	GFI	AGFI	NFI	IFI	CFI	RMSEA
Theoretical Model	1121	399.421/81 = 4.931	.041	.955	.934	0.951	0.961	0.961	0.059
<b>R<sup>2</sup>: HB (34 percent); BI (56 percent)</b>									

#### 5.4 Moderating Effect Analysis

The moderating effect of Gender, Age, Power Distance, Individualism, Feminism, and Uncertainty Avoidance is examined based on the following groups; Gender in males (504) and females (617); Age in Z generation (925) and Y generation (196); Power Distance in higher PD (666) and lower PD (455); Individualism in individualism (253) and collectivism (868); Feminisms in feminisms (95) and Masculinity (1026); Uncertainty Avoidance in lower UA (40) and higher UA (1081). The moderating effect analysis was done using the Multi-Group Analysis feature of AMOS, and the detail of the analysis was shown in Table 15. Furthermore, the fit statistic for the theoretical model to each group in Gender, Age, PD, Individualism, Feminism, and AU was shown in Table 16.

**Table 15. Analysis of direct causal effects for groups in Gender, Age, PD, Individualism, Feminism, and AU**

Causal Direct Effect	Unstandardized Estimate	Statistical Significance	Standardized Estimate	Magnitude	Unstandardized Estimate	Statistical Significance	Standardized Estimate	Magnitude	
<b>Males (N = 504)</b>					<b>Females (N = 617)</b>				
HM→ HB	.347	***	.320	M	.588	***	.576	L	
SI→ HB	.331	***	.295	M	.176	NS	.129	M	
HB→ BI	.592	***	.534	L	.831	***	.701	L	
HM→ BI	.106	NS	.088	S	-.072	NS	-.059	S	
PV→ BI	.254	***	.262	M	.253	***	.109	M	
SI→ BI	.063	NS	.051	S	.025	NS	.016	S	
<b>Age of 14 – 19 / Z generation (N = 925)</b>					<b>Age of 20 – 24 / Y generation (N = 196)</b>				
HM→ HB	.463	***	.465	M	.579	***	.451	M	
SI→ HB	.256	***	.214	M	.147	NS	.101	M	
HB→ BI	.751	***	.626	L	.529	***	.558	L	
HM→ BI	.033	NS	.028	S	.003	NS	.002	S	
PV→ BI	.244	***	.218	M	.291	NS	.270	M	
SI→ BI	.021	NS	.014	S	.149	NS	.109	M	
<b>Higher Power Distance (N = 666)</b>					<b>Lower Power Distance (N = 455)</b>				
HM→ HB	.519	***	.482	M	.417	***	.428	M	
SI→ HB	.212	***	.179	M	.297	***	.237	M	
HB→ BI	.729	***	.615	L	.718	***	.630	L	
HM→ BI	.043	NS	.033	S	-.017	NS	-.015	S	
PV→ BI	.251	***	.221	M	.225	***	.205	M	
SI→ BI	.013	NS	.009	S	.142	NS	.100	M	
<b>Individualism (N = 253)</b>					<b>Collectivism (N = 868)</b>				
HM→ HB	.510	***	.490	M	.480	***	.455	M	
SI→ HB	.226	NS	.176	S	.253	***	.208	M	
HB→ BI	.583	***	.456	M	.738	***	.665	L	
HM→ BI	.261	NS	.196	M	-.044	NS	-.037	S	
PV→ BI	.228	NS	.184	M	.259	***	.242	M	
SI→ BI	.130	NS	.079	S	.021	NS	.016	S	
<b>Feminisms (N = 95)</b>					<b>Masculinity (N = 1026)</b>				
HM→ HB	.593	***	.561	L	.467	***	.444	M	
SI→ HB	.030	NS	.020	S	.260	***	.218	M	

Causal Direct Effect	Unstandardized Estimate	Statistical Significance	Standardized Estimate	Magnitude	Unstandardized Estimate	Statistical Significance	Standardized Estimate	Magnitude	
HB→ BI	.331	NS	.327	M	.756	***	.644	L	
HM→ BI	.230	NS	.215	M	.017	NS	.014	S	
PV→ BI	.273	NS	.285	M	.243	***	.212	M	
SI→ BI	.284	NS	.192	M	.015	NS	.011	S	
<b>Lower UA (N = 40)</b>					<b>Higher UA (N = 1081)</b>				
HM→ HB	.012	NS	.016	S	.499	***	.460	M	
SI→ HB	.629	NS	.890	L	.230	***	.181	M	
HB→ BI	.592	NS	.345	M	.693	***	.619	L	
HM→ BI	.439	NS	.344	M	.019	NS	.016	S	
PV→ BI	.509	NS	.407	M	.242	***	.218	M	
SI→ BI	.108	NS	-.089	S	.049	NS	.035	S	

**Note:** \*, \*\*, and \*\*\* indicate statistical significance at a level of 0.05, 0.01, and 0.001, respectively and NS indicates not statistically significance at a level of 0.05 or less.

**Table 16. Fit statistics for groups in Gender, Age, PD, Individualism, Feminism, and AU**

Group	N	NC ( $\chi^2/df$ )	RMR	GFI	AGFI	NFI	IFI	CFI	RMSEA	R <sup>2</sup> (%)
<b>Gender</b>										
Males	504	230.717/81 = 2.848	.044	.943	.915	0.938	0.959	0.959	0.061	55.0
Females	617	268.390/81 = 3.313	.043	.947	.922	0.943	0.959	0.959	0.061	56.9
<b>Age</b>										
14–19 /Z generation	925	301.674/81 = 3.724	.036	.959	.940	0.953	0.965	0.965	0.054	55.3
20–24 /Y generation	196	215.073/81 = 2.655	.082	.867	.803	0.887	0.926	0.925	0.092	55.5
<b>Power Distance (PD)</b>										
Higher PD	666	285.144/81 = 3.520	.043	.947	.922	0.944	0.960	0.959	0.062	55.1
Lower PD	455	268.901/81 = 3.320	.046	.929	.895	0.918	0.942	0.941	0.071	58.7
<b>Individualism</b>										
Individualism	253	152.280/81 = 1.880	.057	.929	.895	0.920	0.961	0.960	0.059	51.2
Collectivism	868	334.437/81 = 4.129	.040	.951	.927	0.948	0.960	0.960	0.060	57.8
<b>Feminisms</b>										
Feminisms	95	143.076/81 = 1.766	.082	.834	.754	0.863	0.936	0.934	0.090	67.1
Masculinity	1026	352.868/81 = 4.356	.041	.957	.936	0.952	0.962	0.962	0.057	55.5
<b>Uncertainty Avoidance (UA)</b>										
Lower UA	40	160.534/81 = 1.982	.168	.676	.519	0.678	0.810	0.798	0.159	77.2
Higher UA	1081	371.987/81 = 4.592	.041	.957	.936	0.953	0.963	0.962	0.058	54.2

**Note:** R<sup>2</sup> is the proportion of the variance of the variable Behavioral Intention that is explained by the variables affecting it.

The differences in the magnitudes of causal effects between Groups are presented in the details in Table 17. The results in the Table suggest that Gender, Age, and Feminism-Masculinity have a significant moderating effect on Behavioral Intention due to Habit. Furthermore, Gender and Uncertainty Avoidance has a significant moderating effect on Habit due to Hedonic Motivation. Individualism-Collectiveness has a significant moderating effect on Behavioral Intention due to Hedonic Motivation. The Last, Power Distance does not have a significant moderating effect on all the causal effects.

**Table 17: Differences in the magnitudes of causal effects between Groups**

Causal Direct Effect	Magnitude of difference between effects	Critical Difference	Statistical Significance of Difference
<b>Gender (Males compared to Females)</b>			
HM→ HB	.241	2.54	**
SI→ HB	.155	1.55	NS
HB→ BI	.239	2.077	*
HM→ BI	.0179	1.853	NS
PV→ BI	.0001	.017	NS

<b>Causal Direct Effect</b>	Magnitude of difference between effects	Critical Difference	Statistical Significance of Difference
SI→ BI	.038	.379	NS
<b>Age</b> (Z compared to Y generations)			
HM→ HB	.116	0.793	NS
SI→ HB	.109	0.718	NS
HB→ BI	.222	2.033	*
HM→ BI	.030	0.230	NS
PV→ BI	.047	0.466	NS
SI→ BI	.128	1.084	NS
<b>Power Distance</b> (higher PD compared lower PD)			
HM→ HB	.102	1.088	NS
SI→ HB	.085	0.815	NS
HB→ BI	.011	0.095	NS
HM→ BI	.060	0.633	NS
PV→ BI	.026	0.314	NS
SI→ BI	.129	1.197	NS
<b>Individualism</b> (Individualism compared to Collectiveness)			
HM→ HB	.030	0.268	NS
SI→ HB	.027	0.223	NS
HB→ BI	.155	1.164	NS
HM→ BI	.305	2.516	**
PV→ BI	.031	0.319	NS
SI→ BI	.109	0.874	NS
<b>Feminisms</b> (Feminisms compared to Masculinity)			
HM→ HB	.126	0.760	NS
SI→ HB	.230	1.133	NS
HB→ BI	.425	3.378	***
HM→ BI	.213	1.403	NS
PV→ BI	.030	0.225	NS
SI→ BI	.269	1.617	NS
<b>Uncertainty Avoidance</b> (lower UA compared to higher UA)			
HM→ HB	.487	2.498	*
SI→ HB	.399	1.655	NS
HB→ BI	.101	0.099	NS
HM→ BI	.420	1.664	NS
PV→ BI	.267	1.062	NS
SI→ BI	.157	0.217	NS

**Note:** \*, \*\*, and \*\*\* indicate statistical significance at a level of 0.05, 0.01, and 0.001, respectively and NS indicates not statistically significance at a level of 0.05 or less.

## 6. Discussions

### 6.1 The Respondents

The descriptive data show that the respondents of this research have sufficient experience and maturity to deliver reliable and valid responses to the questions regarding online entertainment. Following this description, the distribution of respondents on two groups on moderating factors was adequately more balance except for Age, Feminisms, and Uncertainty Avoidance. That is the limitation of the research related to the respondent balance to satisfy moderating analysis into each of two groups.

The correlation analysis suggests that the five variables, Hedonic Motivation, Social Influence, Price Value, Habit, and Behavioral Intention correlate with each other. Causal effect analysis combines the result to derive findings on the final model. Education, Social Influence, Price Value, and Behavioral Intentions

have positively correlated to Age. As for the other variables, Education has a significant negative correlation to Experience and a significant positive correlation to Social Influence..

### 6.2 Causal Effects

The most influence on the extent to which the user intends to play online entertainment in the future (Behavioral Intention) is the extent to which people tend to perform behaviors automatically because of learning and the behaviors resulted from prior experiences (Habit). The next prominent is the extent to which ‘consumers’ cognitive tradeoff between the perceived benefits of the applications and the monetary cost for using them (Price Value). The statistically significant direct effect of Habit on Behavioral Intention is conformity with the finding by Khatimah (2019), Chopdar (2018), and Venkatesh (2012). Meanwhile, the finding of Price Value has a statistically direct effect on Behavioral Intentions in conformity with the finding by Chopdar (2018), Alalwan (2018), Alshare and Mousa (2014), and Venkatesh (2012). Two variables Hedonic Motivation and Social Influence also have a statistically direct effect on Habit and this findings confirm the finding by Khatimah, et al. (2019). Conversely, other direct effects of Behavioral Intention due to Hedonic Motivation and Social influence are small and not statistically significant. The explanation behind this finding is on including Habit as an intervening variable on the relation of Hedonic Motivation on Behavioral Intention and Social Influence on Behavioral Intention as confirmed by Khatimah, et al. (2019). The decision regarding proposed hypotheses with the direct effect on Behavioral Intention in the theoretical model was presented in Table 18.

**Table 18. Decisions for research hypotheses**

Research Hypotheses	Reference
<b>Supported</b>	
H2: Hedonic Motivation has a statistically direct effect on Habit.	Khatimah (2019)[14]
H3: Habit has a statistically direct effect on Behavioral Intention to use online entertainment.	Khatimah (2019)[14], Chopdar (2018)[15], and Venkatesh (2012)[3]
H5: Social Influence has a statistically direct effect on Habit.	Khatimah (2019)[14]
H6: Price Value has a statistically direct effect on Behavioral Intention to use online entertainment.	Chopdar (2018), Alalwan (2018), Alalwan (2017), Alshare and Mousa (2014), and Venkatesh (2012)
<b>Partially Supported</b>	
H1: Hedonic Motivation has a statistically direct effect on Behavioral Intention to use online entertainment.	Harnadi (2017)[4], Koo (2009)[20], and Lee (2009)[10]
H4: Social Influence has a statistically direct effect on Behavioral Intention to use online entertainment.	Wang & Sun (2016)[7], Fan et al. (2012)[9], Venkatesh (2012)[3], Koo (2009)[20], and Lee (2009)[10]

### 6.3 Moderating Effect analysis

Table 19 displays decisions regarding moderating effect analysis of Gender, Age, Power Distance, Individualism, Feminism, and Uncertainty Avoidance derived from Table 15 and 17.

Research Hypotheses	Comment	
	Effect for Males	Effect for Females
<b>Gender as a moderating effect</b>		
Gender has a significant moderating effect on the direct effect of Hedonic Motivation on Habit	Medium, Positive, Statistically significant	Large, Positive, Statistically significant
Gender has not a significant moderating effect on the direct effect of Social Influence on Habit	Medium, Positive, Statistically significant	Medium, Positive, Not Statistically significant
Gender has a significant moderating effect on the direct effect of Habit on Behavioral Intention	Large, Positive, Statistically significant	Large, Positive, Statistically significant
Gender has not a significant moderating effect on the direct effect of Hedonic Motivation on Behavioral Intention	Small, Positive, Not Statistically significant	Small, Negative, Not Statistically significant
Gender has not a significant moderating effect on the direct effect of Price Value on Behavioral Intention	Medium, Positive, Statistically significant	Medium, Positive, Statistically significant
Gender has not a significant moderating effect on the direct effect of Social influence on Behavioral Intention	Small, Positive, Not Statistically significant	Small, Positive, Not Statistically significant
<b>Age as a moderating effect</b>		
Age has not a significant a moderating effect on the direct effect of Hedonic Motivation on Habit	Medium, Positive, Statistically significant	Medium, Positive, Statistically significant



Research Hypotheses	Comment	
the direct effect of Hedonic Motivation on Behavioral Intention	Statistically significant	Statistically significant
Uncertainty Avoidance has not a significant moderating effect on the direct effect of Price Value on Behavioral Intention	Medium, Positive, Not Statistically significant	Medium, Positive, Statistically significant
Uncertainty Avoidance has not a significant moderating effect on the direct effect of Social influence on Behavioral Intention	Small, Positive, Not Statistically significant	Small, Positive, Not Statistically significant

From Table 19, it was concluded that:

1. For Gender: The moderating effect of Gender exists on the direct causal effect of Hedonic Motivation on Habit and Habit on Behavioral Intention.
2. For Age: The moderating effect of Age only exists on the direct causal effect of Habit on Behavioral Intention.
3. For Power Distance: The moderating effect of Power Distance did not exist on all causal effects in the Theoretical model.
4. For Individualism-Collectivism: The moderating effect of Individualism-Collectivism only exists on the direct causal effect of Hedonic Motivation on Behavioral Intention.
5. For Feminisms-Masculinity: The moderating effect of Feminisms-Masculinity only exists on the direct causal effect of Habit on Behavioral Intention.
6. For Uncertainty Avoidance: The moderating effect of Uncertainty Avoidance only exists on the direct causal effect of Hedonic Motivation on Habit.

### New Findings

The findings regard causal effect analysis with support and partially support the hypotheses derived from the previous research as displayed in Table 18 are not new findings. The new findings of the research come from the findings on moderating effect analysis including the satisfactory fit statistic not reported in previous research. Table 20 emphasizes the new findings related to the moderating effect of Gender, Age, Power Distance, Individualism, Feminism, and Uncertainty Avoidance.

**Table 20. New findings related to the moderating effects of Gender, Age, Power Distance, Individualism, Feminism, and Uncertainty Avoidance**

Moderating effects of Gender, Age, Power Distance, Individualism, Feminism, and Uncertainty Avoidance
<b>Gender</b>
a) <i>Gender has a significant moderating effect on the direct effect of Hedonic Motivation on Habit.</i> <ul style="list-style-type: none"> <li>• <i>For males the effect of Hedonic Motivation on Habit is medium, positive, and statistically significant and for females the effect is large, positive, and statistically significant</i></li> </ul>
b) <i>Gender has a significant moderating effect on the direct effect of Habit on Behavioral Intention.</i> <ul style="list-style-type: none"> <li>• <i>For males and females the effect of Habit on Behavioral Intention is large, positive, and statistically significant.</i></li> </ul>
c) Gender does not have a significant moderating effect on the direct effect of Social Influence on Habit and Hedonic Motivation, Price Value, and Social Influence on Behavioral Intention. <ul style="list-style-type: none"> <li>• For males the effect of Social Influence on Habit is medium, positive, and statistically significant but for females the effect is medium, positive, and not statistically significant.</li> <li>• For males the effect of Hedonic Motivation on Behavioral Intention is small, positive, and not statistically significant and for females the effect is small, negative, and not statistically significant.</li> <li>• For males and females the effect of Price Value on Behavioral Intention is medium, positive, and statistically significant.</li> <li>• For males and females the effect of Social Influence on Behavioral Intention is small, positive, and not statistically significant.</li> </ul>
<b>Age</b>
d) <i>Age has a significant moderating effect on the direct effect of Habit on Behavioral Intention.</i> <ul style="list-style-type: none"> <li>• <i>For the Y and Z generations the effect of Habit on Behavioral Intention is large, positive, and statistically significant.</i></li> </ul>
e) Age does not have a significant moderating effect on the direct effect of Hedonic Motivation or Social Influence on Habit and Hedonic Motivation, Price Value, or Social Influence on Behavioral Intention. <ul style="list-style-type: none"> <li>• For Z and Y generations the effect of Hedonic Motivation on Habit is medium, positive, and statistically significant.</li> </ul>

<b>Moderating effects of Gender, Age, Power Distance, Individualism, Feminism, and Uncertainty Avoidance</b>
<ul style="list-style-type: none"> <li>• For Z generation the effect of Social Influence on Habit and Price Value on Behavioral Intention is medium, positive, and statistically significant but for Y generation the effect is medium, positive, and not statistically significant.</li> <li>• For Z and Y generations the effect of Hedonic Motivation or Social Influence on Behavioral Intention is small, positive, and not statistically significant.</li> </ul>
<b>Power Distance</b>
<p>f) Power Distance does not have a significant moderating effect on the entire causal effect on the theoretical model.</p> <ul style="list-style-type: none"> <li>• For higher and lower Power Distance the effect of Hedonic Motivation or Social Influence on Habit and Price Value on Behavioral Intention is medium, positive, and statistically significant.</li> <li>• For higher and lower Power Distance the effect of Hedonic Motivation or Social Influence on Behavioral Intention is small, positive, and not statistically significant.</li> <li>• For higher and lower Power Distance the effect of Habit on Behavioral Intention is large, positive, and statistically significant.</li> </ul>
<b>Individualism-Collectivism</b>
<p>g) <i>Individualism-Collectivism has a significant moderating effect on the direct effect of Hedonic Motivation on Behavioral Intention.</i> For Individualism the effect of Hedonic Motivation on Behavioral Intention is medium, positive, and not statistically significant and for Collectivism the effect is small, negative, and not statistically significant.</p> <p>h) Individualism-Collectivism does not have a significant moderating effect on the direct effect of Hedonic Motivation or Social Influence on Habit and Habit, Price Value, or Social Influence on Behavioral Intention.</p> <ul style="list-style-type: none"> <li>• For Individualism and Collectivism the effect of Hedonic Motivation on Habit and Habit on Behavioral Intention is medium, positive, and statistically significant.</li> <li>• For Individualism the effect of Social Influence on Habit is small, positive, and not statistically significant but for Collectivism the effect is medium, positive, and statistically significant.</li> <li>• For Individualism the effect of Hedonic Motivation on Behavioral Intention is medium, positive, and not statistically significant and for Collectivism the effect is small, negative, and not statistically significant.</li> <li>• For Individualism the effect of Price Value on Behavioral Intention is medium, positive, and not statistically significant but for Collectivism the effect is medium, positive, and statistically significant.</li> <li>• For Individualism and Collectivism the effect of Social Influence on Behavioral Intention is small, positive, and not statistically significant.</li> </ul>
<b>Feminisms-Masculinity</b>
<p>i) <i>Feminisms-Masculinity has a significant moderating effect on the direct effect of Habit on Behavioral Intention.</i> For Feminisms the effect of Habit on Behavioral Intention is medium, positive, and not statistically significant and <i>for Masculinity the effect is large, positive, and statistically significant.</i></p> <p>j) Feminisms-Masculinity does not have a significant moderating effect on the direct effect of Hedonic Motivation or Social Influence on Habit and Hedonic Motivation, Price Value, or Social Influence on Behavioral Intention.</p> <ul style="list-style-type: none"> <li>• For Feminisms the effect of Hedonic Motivation on Habit is large, positive, and statistically significant and for Masculinity the effect is medium, positive, and statistically significant.</li> <li>• For Feminisms the effect of Social Influence on Habit is small, positive, and not statistically significant but for Masculinity the effect is medium, positive, and statistically significant.</li> <li>• For Feminisms the effect of Hedonic Motivation or Social Influence on Behavioral Intention is medium, positive, and not statistically significant and for Masculinity the effect is small, positive, and not statistically significant.</li> <li>• For Feminisms the effect of Price Value on Behavioral Intention is medium, positive, and not statistically significant but for Masculinity the effect is medium, positive, and statistically significant.</li> </ul>
<b>Uncertainty Avoidance</b>
<p>k) <i>Uncertainty Avoidance has a significant moderating effect on the direct effect of Hedonic Motivation on Habit.</i> For lower Uncertainty Avoidances the effect of Hedonic Motivation on Habit is small, positive, and not statistically significant but <i>for higher Uncertainty Avoidances the effect is medium, positive, and statistically significant.</i></p>

### Moderating effects of Gender, Age, Power Distance, Individualism, Feminism, and Uncertainty Avoidance

- 1) Uncertainty Avoidance does not have a significant moderating effect on the direct effect of Social Influence on Habit and Habit, Hedonic Motivation, Price Value, or Social Influence on Behavioral Intention.
- For lower Uncertainty Avoidances the effect of Social Influence on Habit is large, positive, and not statistically significant but for higher Uncertainty Avoidances the effect is medium, positive, and statistically significant.
  - For lower Uncertainty Avoidances the effect of Habit on Behavioral Intention is medium, positive, and not statistically significant but for higher Uncertainty Avoidances the effect is large, positive, and statistically significant.
  - For lower Uncertainty Avoidances the effect of Hedonic Motivation on Behavioral Intention is medium, positive, and not statistically significant and for higher Uncertainty Avoidances the effect is small, positive, and not statistically significant.
  - For lower Uncertainty Avoidances the effect of Price Value on Behavioral Intention is medium, positive, and not statistically significant but for higher Uncertainty Avoidances the effect is medium, positive, and statistically significant.
  - For lower and higher Uncertainty Avoidances the effect of Social Influence on Behavioral Intention is small, positive, and not statistically significant.

#### 6.4 Implications

This research confirms the findings contributing to the current literature. Firstly, the previous literature on acceptance of e-money focuses on Habit as a mediator on the acceptance (Khatimah et al., 2019). The literature examines the effect of Hedonic Motivation and Social Influence on Habit and afterward on Behavioral Intention. The other literature (Baabdullah et al., 2019; Chopdar et al., 2018; Venkatesh et al., 2012) proposes Hedonic Motivation, Habit, and Price Value to have a significant direct effect on Behavioral Intention. Our research proposed and tested the mediator effect of Habit on acceptance of online entertainment. We also add Hedonic Motivation and Social Influence to have a direct effect on Habit and Price value to have a direct effect on Behavioral Intention. This research contributes to the existing literature on online entertainment concerning Habit as a mediator have a direct effect on Behavioral Intention and integrating Price Value as a factor to have a direct effect on Behavioral Intention. Our empirical findings seem congruent with the study conducted by Khatimah et al. (2019) that states Hedonic Motivation and Social Influence have a direct effect on Habit and Habit on Behavioral Intention. The finding also seems congruent with the study conducted by Baabdullah et al. (2019), Chopdar et al. (2018), and Venkatesh et al. (2012). The interesting findings also enhance the comprehension of theory application in the online entertainment context.

Secondly, the moderating effect of Age and Gender on previous literature come from studies on online gaming and acceptance of technology in general (Harnadi, 2017; Akbar, 2013; Venkatesh et al., 2012; Lee, 2009; Wang and Wang, 2008; Venkatesh et al., 2003). The moderating effect of cultural factors on previous literature in the e-learning and mobile payment device context comes from Tarhini et al. (2016) and Alshare and Mousa (2014). This research reveals that in the acceptance of online entertainment context, the effect of Hedonic Motivation on Habit is greater on females than males and the effect of Habit on Behavioral Intention is equal for males and females. Subsequently, the effect of Habit on Behavioral Intention is equal for the Z and Y generation. Furthermore, the findings on cultural factors as a moderating effect reveal that Individualism-Collectivism has a significant moderating effect on the direct effect of Hedonic Motivation on Behavioral Intention. Moreover, the effect of Habit on Behavioral Intention is only on Masculinity and not on Feminisms. Finally, the effect of Hedonic Motivation on Habit is only on higher Uncertainty Avoidances and not on lower Uncertainty Avoidances.

This research proposes practical implications for practitioners, educators, parents, and online application developer for entertainment. Practitioners need to improve the effectiveness of their methods for online ads embedded in an application. Seemingly, the effectiveness methods must consider the consumers of the application. The findings of research offer the segmentation and targeting insight regarding the different ages, gender, and culture of the consumers. Moreover, educators and parents need to know the characteristics of consumers of the applications. Their student and children are the consumers of the application. The information provided by this research can be used as a guide to know their level of passion and practice in using the application. Eventually, this research can serve the application developers the insight on how to design the applications to fulfill the consumers of different ages, genders, and cultures and their perceptions in using the application.



## 6.5 Limitations and future work

First of all, this research on the role of age, gender, and cultural factors as moderators on the acceptance of online entertainment appears to be the first conducted in the context of Indonesia. Therefore, there is a limitation on its external validity so that future work is recommended to repeat. Second, the generalizability of the research findings should be reviewed. Future works must consider different groups related to ages to repeating the test of the research. The expansion of the theoretical model is possible to future work by introducing other constructs such as Perceived Usefulness and Perceived Ease of Use as offered in the Technology Acceptance Model (TAM) by Davis (1989). Third, we employed Hofstede's cultural dimensions by Straub (1997) to test their effect on the acceptance of online entertainment. The future work may replace or expand the dimension with other cultural factors from other literature.

## 7. Conclusions

The result of the research encloses findings confirming the previous studies which state that people tend to perform behaviors automatically in using online media entertainment depends on their perception that using it is fun and the importance other people believe that they should use it. Furthermore, the nature of the user of online entertainment in using online entertainment in the future is affected by the important other's belief that they should use it and their perception that using it is fun. The new findings of this research relating to moderation effect analysis confirm that age, gender, and cultural factors have a role in the acceptance of online entertainment. However, the effect of Hedonic Motivation on Habit was important for: females than males; and higher Uncertainty Avoidances but not lower Uncertainty Avoidances. Furthermore, the effect of Habit on Behavioral Intention was also important for: both males and females; both Z and Y generations; and Masculinity but not for Feminisms. The other findings concern the usage rates for online entertainment in Table 11, almost all of the respondents (80 percent) use for every day in a week with almost half of these using up to 15 hours per week. Based on these findings, parents and teachers may give guidance to online entertainment lovers to manage their time better for study and take pleasure.

## Acknowledgment

The authors gratefully acknowledge the Directorate General of Higher Education, Ministry of Education and Culture, Republic of Indonesia, which provide research project including the support from the Department of Information Systems, Soegijapranata Catholic University, Indonesia.

## Notes

- [18] Kemp, S. "Special Reports, Digital Use Around the World in July 2020," *wearesocial.com*, July. 21, 2020. retrieved from <https://wearesocial.com/blog/2020/07/digital-use-around-the-world-in-july-2020>. [Accessed: Nov. 13, 2020].
- [19] Hootsuite & We Are Social, "Digital 2020: Indonesia," *datareportal.com*, February. 18, 2020, retrieved from <https://datareportal.com/reports/digital-2020-indonesia>. [Accessed: Nov. 13, 2020].

## References

- Akbar, F., (2013), "What affects students' acceptance and use of technology?" Theses Report, Dietrich College of Humanities and Social Sciences.
- Alalwan, A. A., Dwivedi, Y. K., Rana, N. P., Algharabat, R., (2018), "Examining factors influencing Jordanian customers' intentions and adoption of internet banking: Extending UTAUT2 with risk," *Journal of Retailing and Consumer Services*, Vol. 40, pp.125-138.
- Alshare, K. A., and Mousa, A. A., (2014), "The Moderating Effect of Espoused Cultural Dimensions on Consumer's Intention to Use Mobile Payment Devices," *Thirty Fifth International Conference on Information Systems*, Auckland, pp. 1-15.
- Baabdullah, A. M., Alalwan, A. A., Rana, N. P., Kizgin, H., and Patil, P., (2019), "Consumer use of mobile banking (M-Banking) in Saudi Arabia: Towards an integrated model," *International Journal of Information Management*, Vol. 44, pp. 38-52.
- Chen, C.-P., (2018), "Understanding mobile English-learning gaming adopters in the self-learning market: The Uses and Gratification Expectancy Model," *Computers & Education*, Vol. 126, pp 217-230.
- Cohen, J., (1988), *Statistical power analysis for the behavioral sciences* (2nd ed.), Academic Press, New York, NY.
- Chawla, D. and Joshi, H. (2020), "The moderating role of gender and age in the adoption of mobile wallet", *Foresight*, Vol. 22 No. 4, pp. 483-504.
- Chopdar, P. K., Korfiatis, N., Sivakumar, VJ., and Lytras M. D., (2018), "Mobile shopping apps adoption and perceived risks: A cross-country perspective utilizing the Unified Theory of Acceptance and Use of Technology," *Computers in Human Behaviour*, Vol. 86, pp. 109-128.
- Davis, F. D. (1989). "Perceived Usefulness, Perceived Ease of Use, and User Acceptance of Information Technology," *Management Information Systems Quarterly*, Vol. 13 No. 3, pp. 319-340.
- Fan, L., Ghu, C. G., Suh, Y. H., & Lee, S. C., (2012), "How to attract Chinese online game users," *Asian Journal on Quality*, Vol. 13 No. 1, 7-27.

- Harnadi, B., (2017), "An investigation of the adoption of online game technologies in Indonesia," *International Journal of Gaming and Computer-Mediated Simulations*, Vol.9 No. 1, pp. 1–27.
- Khatimah, H., Susanto, P., and Abdullah, N. L., (2019), "Hedonic Motivation and Social Influence on Behavioral Intention of E-Money: The Role of Payment Habit as a Mediator," *International Journal of Entrepreneurship*, Vol. 23 No. 1, pp. 1-9.
- Kline, R. B., (2005), *Principles and Practice of Structural Equation Modeling*, Guilford Press, London.
- Koo, D. M., (2009), "The moderating role of locus of control on the links between experiential motives and intention to play online games. *Computers in Human Behavior*, Vol. 25 No. 2, pp. 466–474.
- Lee, M. C., (2009), "Understanding the Behavioural Intention to Play Online Games," *Online Information Review*, Vol. 33 No. 5, pp. 849–872.
- Luo, M.M., Chea, S., and Chen, J.-S., (2011), "Web-based information service adoption: A comparison of the motivational model and the uses and gratifications theory," *Decision Support Systems*, Vol. 51, pp. 21-30.
- Merhi, M., Hone, K., Tarhini, A. and Ameen, N. (2020), "An empirical examination of the moderating role of age and gender in consumer mobile banking use: a cross-national, quantitative study", *Journal of Enterprise Information Management*, Vol. ahead-of-print No. ahead-of-print.
- Merikivi, J., Tuunainen V. & Duyen, N., (2017), "What Makes Continued Mobile Gaming Enjoyable?" *Computers in Human Behavior*, Vol. 68, pp. 411-421.
- Šorgo, A., Bartol, T., Dolničar, D. and Boh Podgornik, B. (2017), Attributes of digital natives as predictors of information literacy in higher education. *Br J Educ Technol*, Vol. 48, pp. 749-767.
- Straub, D., Keil, M., and Brenner, W., (1997), "Testing the technology acceptance model across cultures: A three country study," *Information and Management*, Vol. 33, pp. 1 – 11.
- Tarhini, A., Hone, K., Liu, X., and Tarhini, T., (2017), "Examining the moderating effect of individual level cultural values on users' acceptance of Elearning in developing countries: a structural equation modeling of an extended technology acceptance model," *Interactive Learning Environments*, Vol. 25 No. 3, pp. 306-328.
- Venkatesh, V., Morris, M. G., Davis, G. B., and Davis, F. D., (2003), "User acceptance of information technology: toward a Unified View," *MIS Quarterly*, Vol. 27, No. 3, pp. 425–479.
- Venkatesh, V., Thong, J. Y. L., & Xu, X., (2012), "Extending the Unified Theory of Acceptance and Use of Technology", *MIS Quarterly*, Vol. 36 No. 1, pp. 157–178.
- Wang, Q. and Sun, X., (2016), "Investigating gameplay intention of the elderly using an Extended Technology Acceptance Model (ETAM)," *Technological Forecasting & Social Change*, Vol. 107, pp. 59-68.
- Wei, P. S., & Lu, H. P., (2014), "Why do people play mobile social games? An examination of network externalities and of uses and gratifications," *Internet Research*, Vol. 24 No. 3, pp. 313–33.
- Wang, H. Y., & Wang, Y. S., (2008) "Gender differences in the perception and acceptance of online games," *British Journal of Educational Technology*, Vol. 39 No. 5, pp. 787–806.

## Appendix

### Questionnaire

#### A. Latent Variables

##### Hedonic Motivation

- While playing online entertainment, I feel happy.
- I feel that playing online entertainment makes me relax.
- Playing online entertainment, keep me entertained.

##### Price Value

- In my opinion, the price of using online entertainment is still reasonable.
- The benefits of using online entertainment are equivalent to the money I have spent.
- With the price incurred, the use of online entertainment still benefits me.

##### Social Influence

- People who are influential to me, think that it is not a problem for them if I play entertainment online.
- People who are important to me think that it is not a problem for them if I play online entertainment media.
- People whom I respect for their opinions suggest that I keep playing the online entertainment media.

##### Habit

- Playing online entertainment has become a habit for me.
- I have to play online entertainment.
- I feel addicted to online entertainment.

##### Behavioral Intention

- I intend to continue playing online entertainment in the future.
- I predict that I will continue to play online entertainment.
- I plan to continue playing online entertainment.

#### B. Cultural Variables

##### Power Distance

- Teachers/Lecturers must make most decisions without consulting students.
- Teachers/Lecturers should not ask students' opinions too often.
- Students must agree with the decisions made by the Teacher/Lecturer and the school/university management.

#### Individualism

- It is better to study/work in groups than alone.
- Group success is more important than individual success.
- Awards for individuals are less important than rewards for groups.

#### Feminisms

- It is important for me to appreciate outstanding academic achievements.
- It is important for me to focus more on achieving superior academic achievements.
- It's important for me to outperform my classmates.

#### Uncertainty Avoidance

- Rules and regulations are important because they tell students what to expect from the school/university.
- It's important to know the specific requirements and instructions spelled out in detail so I always know what to do.
- Standardized operational work instructions and procedures are very helpful for my learning.

**D. STATUS LUARAN:** Tuliskan jenis, identitas dan status ketercapaian setiap luaran wajib dan luaran tambahan (jika ada) yang dijanjikan. Jenis luaran dapat berupa publikasi, perolehan kekayaan intelektual, hasil pengujian atau luaran lainnya yang telah dijanjikan pada proposal. Uraian status luaran harus didukung dengan bukti kemajuan ketercapaian luaran sesuai dengan luaran yang dijanjikan. Lengkapi isian jenis luaran yang dijanjikan serta unggah bukti dokumen ketercapaian luaran wajib dan luaran tambahan melalui Simlitabmas.

Secara ringkas dapat disebutkan dalam laporan kemajuan 70% ini luaran yang telah tercapai adalah:

1. Luaran wajib:  
Dokumen Hasil Uji Coba Produk  
“Website E-Marketplace dcreatifunika.id”  
yang digunakan untuk meningkatkan potensi industri kreatif dan UMKM
2. Publikasi pada Konferensi Internasional  
Status: Accepted  
Berkas telah diunggah di sistem Simlibtabmas
3. Publikasi Seminar Nasional  
Status: Submit
4. Publikasi Jurnal Internasional  
Status: Submit

Berkas accepted pada publikasi Konferensi Internasional ICIC-Aptikom 2020



Bernardinus Hamadi &lt;bhamadi@unika.ac.id&gt;

**Fwd: icic2020 notification for paper 118**

2 messages

Fx. Hendra Prasetya <hendra@unika.ac.id>  
To: Bernardinus Hamadi <bhamadi@unika.ac.id>  
Cc: Yoga Widiantoro <yoga@unika.ac.id>

Sat, Sep 19, 2020 at 5:58 PM

Pengumuman ICIC 2020

----- Forwarded message -----

From: icic2020 <icic2020-0@easychair.org>  
Date: Sab, 19 Sep 2020 5:08 PM  
Subject: icic2020 notification for paper 118  
To: Fx Hendra Prasetya <hendra@unika.ac.id>

Dear Fx Hendra Prasetya

We are pleased to inform you that your paper:  
Paper ID: 118

Title: Investigating the Impact of System and Service Qualities on Customer Loyalty in Acceptance of E-Marketplace

that submitted to the 5th International Conference on Informatics and Computing (ICIC2020) has been ACCEPTED for an oral presentation. We cordially invite you to attend by presenting your paper in the ICIC2020.

It is mandatory to prepare the camera-ready paper as per the instructions listed on ICIC2020 website (<https://icic-aplikom.org/2020/preparing-final-manuscript/>) and your paper will not be published unless the following are done:

1. Revise your paper(s) according to the reviewers' comments. The detail review is listed in the below of this email.
2. The accepted similarity level is maximum 20% which you may check using Turnitin or other similar plagiarism check.
3. Format your camera-ready paper as per guidelines and follow strictly the A4-IEEE format in pdf file by creating it using IEEE pdf express. (<https://www.pdf-express.org/plus>)
4. Fill the registration form that can be accessed from the website (<https://icic-aplikom.org/2020/#registration>) and submit it to co including the proof of your payment and proof of student status when it is relevant.
5. Send your camera-ready paper (in MS Word and PDF) also the presentation file to forms.gle/mPN3biujstQRVY8p9.
6. Electronic IEEE copyright form will be sent to the correspondent e-mail for each of your accepted paper.

Please be reminded that the due date for early bird registration is 15 October 2020. At least one author has to register for the conference.

The conference will take place by VIRTUAL from 3rd – 4th November 2020. As soon as the schedule is completed, it will be posted on the conference website.

All related conference materials can be found at <https://icic-aplikom.org/> Please let us know if you have any questions regarding registration.

With a warmest regard,

Technical Program Chairs  
Achmad Nizar Hidayanto  
Husni Teja Sukmana  
Prihandoko

SUBMISSION: 118

TITLE: Investigating the Impact of System and Service Qualities on Customer Loyalty in Acceptance of E-Marketplace

----- REVIEW 1 -----

SUBMISSION: 118

3/12/2020

Soegijapranata Catholic University Mail - Fwd: lcic2020 notification for paper 118

TITLE: Investigating the Impact of System and Service Qualities on Customer Loyalty in Acceptance of E-Marketplace  
AUTHORS: Fx Hendra Prasetya, Bernardinus Hamadi, Agus Nugroho and Albertus Widiartoro

Overall evaluation

SCORE: 2 (accept)

TEXT:

This paper aims to investigate the influence of System and Service Quality on Customer Loyalty in their acceptance of e-marketplaces.

REVIEW 2

SUBMISSION: 118

TITLE: Investigating the Impact of System and Service Qualities on Customer Loyalty in Acceptance of E-Marketplace  
AUTHORS: Fx Hendra Prasetya, Bernardinus Hamadi, Agus Nugroho and Albertus Widiartoro

Overall evaluation

SCORE: 2 (accept)

TEXT:

Below are my comments on this paper:

1. Congratulation to the authors for this paper that has been written well.
2. Please discuss the research gaps clearly in the introduction section.
3. Add the e-commerce context when developing the hypotheses.
4. Please add discussion and implications of your findings both on practices and theories.

Fx. Hendra Prasetya <hendra@unika.ac.id>  
To: Bernardinus Hamadi <bhamadi@unika.ac.id>

Tue, Dec 1, 2020 at 10:52 AM

[Quoted text hidden]

Powered by [unika.ac.id](https://unika.ac.id) mail service

<https://mail.google.com/mail/u/1/?ik=a997ad7f96&view=pt&search=all&permthid=thread-F%3A1678259632133806272&siml=msg-F%3A16782596321...> 2/2

**E. PERAN MITRA:** Tuliskan realisasi kerjasama dan kontribusi Mitra baik *in-kind* maupun *in-cash* (untuk Penelitian Terapan, Penelitian Pengembangan, PTUPT, PPUPT serta KRUP). Bukti pendukung realisasi kerjasama dan realisasi kontribusi mitra dilaporkan sesuai dengan kondisi yang sebenarnya. Bukti dokumen realisasi kerjasama dengan Mitra diunggah melalui Simlitabmas.

Realisasi Kerjasama dan kontribusi dengan Mitra

In-kind:

- masukan desain perancangan sistem website e-marketplace digital kreatif dcreatifunika.id
- review/evaluasi website e-marketplace digital kreatif dcreatifunika.id

In-cash: -



Bukti dokumen realisasi kerjasama dengan Mitra telah diunggah melalui Simlitabmas.

**F. KENDALA PELAKSANAAN PENELITIAN:** Tuliskan kesulitan atau hambatan yang dihadapi selama melakukan penelitian dan mencapai luaran yang dijanjikan, termasuk penjelasan jika pelaksanaan penelitian dan luaran penelitian tidak sesuai dengan yang direncanakan atau dijanjikan.

Kesulitan dan hambatan dalam penelitian

- Jumlah mitra industri kreatif digital masih sedikit
- Waktu untuk menyelesaikan kegiatan penelitian sangat terbatas

Kesulitan dan hambatan dalam mencapai Luaran Penelitian

- Waktu untuk mencapai Luaran Penelitian sangat terbatas

**G. RENCANA TAHAPAN SELANJUTNYA:** Tuliskan dan uraikan rencana penelitian di tahun berikutnya berdasarkan indikator luaran yang telah dicapai, rencana realisasi luaran wajib yang dijanjikan dan tambahan (jika ada) di tahun berikutnya serta *roadmap* penelitian keseluruhan. Pada bagian ini diperbolehkan untuk melengkapi penjelasan dari setiap tahapan dalam metoda yang akan direncanakan termasuk jadwal berkaitan dengan strategi untuk mencapai luaran seperti yang telah dijanjikan dalam proposal. Jika diperlukan, penjelasan dapat juga dilengkapi dengan gambar, tabel, diagram, serta pustaka yang relevan. Jika laporan kemajuan merupakan laporan pelaksanaan tahun terakhir, pada bagian ini dapat dituliskan rencana penyelesaian target yang belum tercapai.

#### **Rencana Penyelesaian Target Luaran untuk ketercapaian 100 %**

Secara kegiatan tinggal 1 kegiatan yaitu workshop dan launching website e-marketplace dcreatifunika.id. Persiapan sudah dilakukan tinggal pelaksanaannya.

#### **Rencana Penyelesaian Target Luaran yang belum tercapai**

Target luaran tambahan:

1. Konferens internasional ICIC Aptikom 2020 sudah terlaksana, tinggal menunggu published
2. Paper Seminar nasional telah disubmitted ke 2021 3rd EAST INDONESIA CONFERENCE ON COMPUTER AND INFORMATION TECHNOLOGY (EIConCIT)
3. Paper Jurnal Internasional sudah di submit ke jurnal Online Information Review

**H. DAFTAR PUSTAKA:** Penyusunan Daftar Pustaka berdasarkan sistem nomor sesuai dengan urutan pengutipan. Hanya pustaka yang disitasi pada laporan kemajuan yang dicantumkan dalam Daftar Pustaka.

1. Novianty, C., 2017, "Review Konsep Responsive Design dengan Framework Materialize pada Website", Jurnal Nasional Informatika dan Teknologi Jaringan, vol.2, no 1.
2. Anandhita, R. Z., Kertahadi, Suyadi, I., 2014, "Analisis Atas Desain Website Ecommerce ZGS Game Shop", Jurnal Administrasi Bisnis, vol.9, No.1.
3. Bruner, G.C., Kumar, A., 2000, "Commercials and Advertising Hierarchy-of-Effects", Web Journal of Advertising Research, Januari-April, 2000.
4. Parasuraman A., 2000, "Technology Readiness Index (Tri): A Multiple-Item Scale to Measure Readiness to Embrace New Technologies". Journal of Service Research. 2000;2(4):307-320. doi:10.1177/109467050024001
5. Lawrence, J.E., Tar, U.A., "Barriers to ecommerce in developing countries," Inform. Soc. Justice, vol. 3, no. 1, pp. 23–35, 2010
6. E. Brynjolfsson, Y. (Jeffrey) Hu, and M. S. Rahman, "Battle of the Retail Channels: How Product Selection and Geography Drive Cross-Channel Competition," Manage. Sci., vol. 55, no. 11, pp. 1755–1765, 2009, doi: 10.1287/mnsc.1090.1062.
7. T. M. Nisar and G. Prabhakar, "What factors determine e-satisfaction and consumer spending in e-commerce retailing?," J. Retail. Consum. Serv., vol. 39, no. July, pp. 135–144, 2017, doi:

10.1016/j.jretconser.2017.07.010.

8. R. Z. Kuo, "EMRS Adoption: Exploring the effects of information security management awareness and perceived service quality," *Heal. Policy Technol.*, vol. 7, no. 4, pp. 365–373, 2018, doi: 10.1016/j.hlpt.2018.10.012.
9. Oh, J.-C., & Yoon, S.-J., "Predicting The Use of Online Information Services Based On A Modified UTAUT Model," *Behaviour & Information Technology*, vol.33, no. 7, pp. 716–729, 2014.
10. Ramayasa, I. P., "Evaluation Model of Success And Acceptance of e-Learning," *Journal of Theoretical and Applied Information Technology*, vol 82, no. 3, pp. 462, 2015.
11. Farzin, S., & Dahlan, H. M., "Proposing A Model To Predict Students' perception Towards Adopting An E-Assessment System," *Journal of Theoretical & Applied Information Technology*, vol. 90, no. 1, 2016.
12. Malik Bader Alazzam, A., Samad Hasan Basari, A. S. S., Ibrahim, Y. M., Ramli, M. R., & Naim, M. H., "Trust In Stored Data In Ehra Acceptance Of Medical Staff: Using UTAUT2," *International Journal of Applied Engineering Research*, vol. 11, no. 4, pp. 2737–2748, 2016.
13. [9] D. M. Mansur, E. T. Sule, D. Kartini, Y. M. Oesman, A. H. P. K. Putra, and N. Chamidah, "Moderating of the role of technology theory to the existence of consumer behavior on e-commerce," *J. Distrib. Sci.*, vol. 17, no. 7, pp. 15–25, 2019, doi: 10.15722/jds.17.07.201907.15.
14. Yuan, S., Ma, W., Kanthawala, S. and Peng, W., "Keep using my health apps: discover users' perception of health and fitness apps with the UTAUT2 model", *Telemedicine and e-Health*, Vol. 21 No. 9, pp. 735-741, 2015.
15. Beldad, A.D. and Hegner, S.M., "Expanding the technology acceptance model with the inclusion of trust, social influence, and health valuation to determine the predictors of German users' willingness to continue using a fitness app: a structural equation modeling approach", *International Journal of Human-Computer Interaction*, Vol. 34 No. 9, pp. 882-893, 2018.
16. Chen, M.-F. and Lin, N.-P., "Incorporation of health consciousness into the technology readiness and acceptance model to predict app download and usage intentions", *Internet Research*, Vol. 28 No. 2, pp. 351-373, 2018.
17. Cho, J., "The impact of post-adoption beliefs on the continued use of health apps", *International Journal of Medical Informatics*, Vol. 87, pp. 75-83, 2016.
18. Giovanis, A., "Consumer-brand relationships' development in the mobile internet market: evidence from an extended relationship commitment paradigm", *The Journal of Product and Brand Management*, Vol. 25 No. 6, pp. 568-585, 2016.
19. Giovanis, A. and Athanasopoulou, P., "Consumer-brand relationships and brand loyalty in technology-mediated services", *Journal of Retailing and Consumer Services*, Vol. 40, pp. 287-294, 2018.
20. Uysal, A., "Commitment to multiplayer online games: an investment model approach", *Computers in Human Behavior*, Vol. 61, pp. 357-363, 2016.
21. Odrowska, A.M. and Massar, K., "Predicting guild commitment in World of Warcraft with the investment model of commitment", *Computers in Human Behavior*, Vol. 34, pp. 235-240, 2014.
22. Lin, J.-S., Sung, Y. and Chen, K.-J., "Social television: examining the antecedents and consequences of connected TV viewing", *Computers in Human Behavior*, Vol. 58, pp. 171-178. 2016.
23. Jin, X.-L., Lee, M.K.O. and Cheung, C.M.K., "Predicting continuance in online communities: model development and empirical test AU -Jin, Xiao-Ling", *Behaviour and Information Technology*, Vol. 29 No. 4, pp. 383-394, 2010.
24. W. Chiu, H. Cho, and C. G. Chi, "Consumers' continuance intention to use fitness and health apps: an integration of the expectation–confirmation model and investment model," *Inf. Technol. People*, 2020, doi: 10.1108/ITP-09-2019-0463.
25. Aslam, W., Ham, M. and Farhat, K., "Building Brand Loyalty: An Application of Expectation Confirmation Model in Mobile Social Commerce," *Journal of Commerce and Social Sciences*, Vol. 13, no.4, pp. 806-825, 2019.
26. Fan, L., & Suh, Y. H., "Why do users switch to a disruptive technology? An empirical study based on expectation-disconfirmation theory," *Information & Management*, vol. 51, no. 2, pp. 240–248, 2014.



27. Kim, D. J., Ferrin, D. L., & Rao, H. R., "Trust and satisfaction, two stepping stones for successful e-commerce relationships: A longitudinal exploration," *Information systems research*, vol. 20, no. 2, pp. 237-257, 2009.
28. Bhattacharjee, A., & Premkumar, G., "Understanding changes in belief and attitude toward information technology usage: A theoretical model and longitudinal test," *MIS quarterly*, vol. 28, pp. 229-254, 2004.
29. Halilovic, S., & Cicic, M., "Antecedents of information systems user behaviour—extended expectation-confirmation model," *Behaviour & Information Technology*, vol. 32, no. 4, pp. 359-370, 2013.
30. Stone, R. W., & Baker-Eveleth, L., "Students' expectation, confirmation, and continuance intention to use electronic textbooks," *Computers in Human Behavior*, vol. 29, no. 3, pp. 984–990, 2013.
31. Wu, I. L., "The antecedents of customer satisfaction and its link to complaint intentions in online shopping: An integration of justice, technology, and trust," *International Journal of Information Management*, vol. 33, no. 1, pp. 166–176, 2013.
32. Bhattacharjee, A., "Understanding information systems continuance: an expectation-confirmation model," *MIS Quarterly*, vol. 25, pp. 351-370, 2001.
33. I. W. K. Wijaya, A. A. G. Rai, and T. Hariguna, "The impact of customer experience on customer behavior intention use in social media commerce, an extended expectation confirmation model: An empirical study," *Manag. Sci. Lett.*, vol. 9, no. 12, pp. 2009–2020, 2019, doi: 10.5267/j.msl.2019.7.005.
34. D. Lestari, "Measuring e-commerce adoption behaviour among gen-Z in Jakarta, Indonesia," *Econ. Anal. Policy*, vol. 64, pp. 103–115, 2019, doi: 10.1016/j.eap.2019.08.004.
35. E. Park, "User acceptance of smart wearable devices: An expectation-confirmation model approach," *Telemat. Informatics*, vol. 47, no. December 2019, 2020, doi: 10.1016/j.tele.2019.101318.
36. G. Dağhan and B. Akkoyunlu, "Modeling the continuance usage intention of online learning environments," *Comput. Human Behav.*, vol. 60, pp. 198–211, 2016, doi: 10.1016/j.chb.2016.02.066.
37. C. Tam, D. Santos, and T. Oliveira, "Exploring the influential factors of continuance intention to use mobile Apps: Extending the expectation confirmation model," *Inf. Syst. Front.*, vol. 22, no. 1, pp. 243–257, 2020, doi: 10.1007/s10796-018-9864-5.
38. F. X. H. Prasetya and B. Harnadi, "Investigation of Adoption of Smartphone Technology for Learning," *ICSEC 2019 - 23rd Int. Comput. Sci. Eng. Conf.*, pp. 251–254, 2019, doi: 10.1109/ICSEC47112.2019.8974802.

Dokumen pendukung luaran Wajib #1

Luaran dijanjikan: Dokumentasi hasil uji coba produk

Target: Ada

Dicapai: Tersedia

Dokumen wajib diunggah:

1. Dokumentasi (foto) Pengujian Produk
2. Dokumen Deskripsi dan Spesifikasi Produk
3. Dokumen Hasil Uji Coba Produk

Dokumen sudah diunggah:

1. Dokumen Deskripsi dan Spesifikasi Produk
2. Dokumen Hasil Uji Coba Produk
3. Dokumentasi (foto) Pengujian Produk

Dokumen belum diunggah:

- Sudah lengkap

Nama Produk: Website E-Marketplace dcreatifunika.id

Tgl. Pengujian: 26 November 2020

Link Dokumentasi:

<https://drive.google.com/drive/folders/1AFFdE85fwRt9cjdpPCgS7xfSlihjo83V>

# Dokumen “Deskripsi dan Spesifikasi Produk” Website E-Marketplace dcreatifunika.id

## I. Deskripsi:

Website E-Marketplace dcreatifunika.id merupakan produk penelitian berupa website e-marketplace yang diperuntukkan bagi pelaku Industri Kreatif Digital. Dan karena masa pandemic Covid-19 melanda Indonesia dan berdampak pada para pelaku UMKM di Indonesia, maka website E-Marketplace dcreatifunika.id juga dipersembahkan bagi para pelaku UMKM.

Nama dcreatifunika merupakan singkatan dari digital creative dan unika merupakan nama Universitas Katolik Soegijapranata atau biasa disingkat Unika Soegijapranata. Website dirancang dan dibangun dengan menggunakan konsep pengembangan aplikasi Waterfall Model.

## II. Spesifikasi Produk:

Website dirancang dengan menggunakan Use Case Diagram dan ERD Diagram sebagai berikut:

### A. Perancangan Use Case Diagram

Use Case Diagram dikembangkan pada tahap awal pengembangan dan orang sering menerapkan pemodelan use case dengan tujuan: menentukan konteks sistem, mendapatkan/menangkap persyaratan sistem, melakukan validasi arsitektur sistem, dikembangkan oleh analis untuk menetapkan aktivitas sistem.

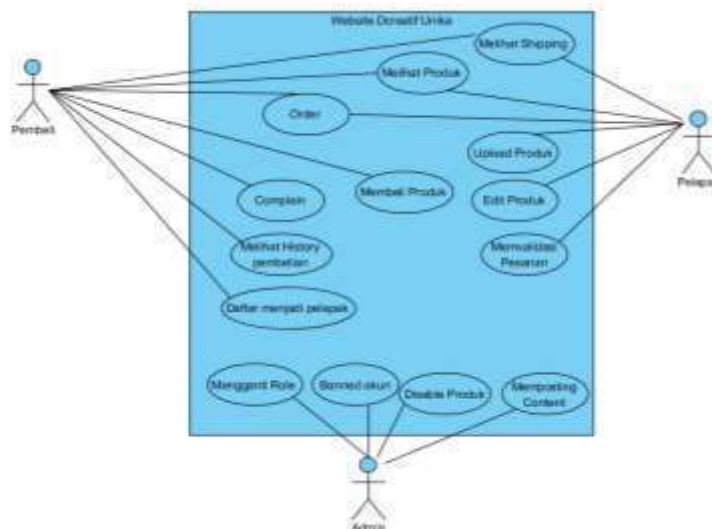

Figure 1. Use Case Diagram

Dalam sistem e-commerce dcreatifunika.id ini actor yang terlibat adalah pembeli, pelapak, dan administrator sistem. Pembeli melakukan aktivitas melihat shopping, melihat produk, membeli produk, complain, melihat histori, mendaftar menjadi pelapak. Pelapak melakukan

aktivitas melihat shopping, melihat produk, upload produk, edit produk, membalidasi pesanan. Sementara admin (administrator sistem) melakukan penggantian role, banned akun, disable produk, memposting konten, melakukan klasifikasi produk.

## B. Perancangan ERD Diagram

Database Utama E-Commerce dcreatifunika.id terdiri dari beberapa tabel yaitu: Kategori, Produk, Order Detail, Order, Nota, Pembayaran, Shopping, Toko, User, Province, dan City seperti yang terlihat pada Gambar. Proses normalisasi telah dilakukan, sehingga tabel-tabel yang dibangun menjadi database lebih mudah dalam: Pengelompokan Data, Mencegah Data Ganda, Memudahkan Pengelolaan Data Perusahaan, Menjaga Kualitas Data, Meningkatkan Kinerja Aplikasi, Menjaga Kerahasiaan Data, dan Memudahkan Berbagi Data.

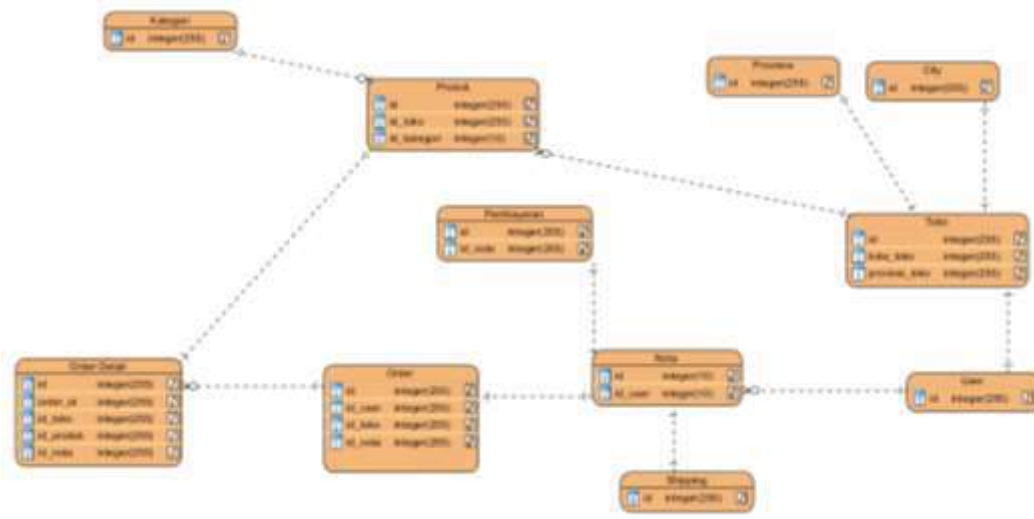

Figure 2. ERD Diagram

Website dibangun dengan pembagian sebagai berikut:

- A. Halaman Utama (Main Page)
- B. Sisi Pembeli (Buyer Page)
- C. Sisi Penjual/Pelapak (Seller Page)

Berikut detailnya:

### A. Main page

Tampilan utama menampilkan produk-produk yang telah dimasukkan oleh pelapak. Tampilan ini dapat dilihat tidak perlu melakukan registrasi. Didalam tampilan depan ini dapat melihat kategori produk, melakukan sign-up dan melakukan sign-in.

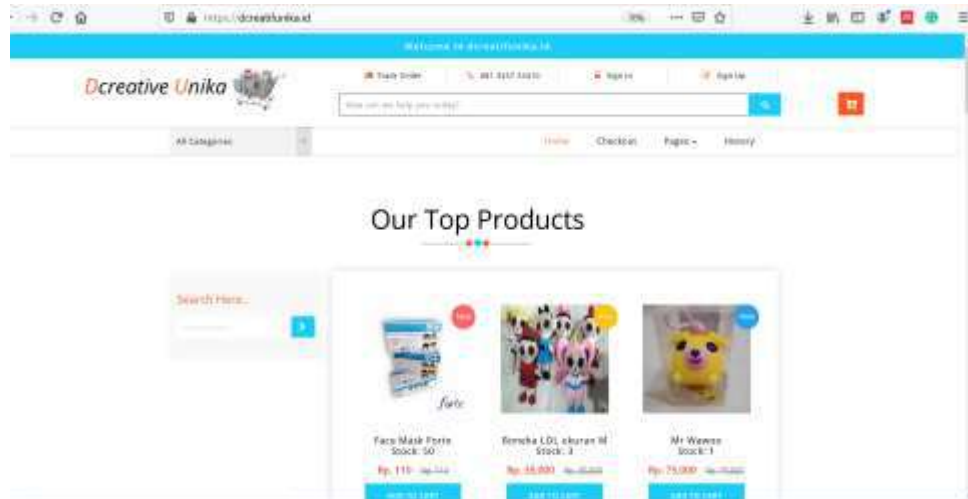

Figure 3. Main Page

### Sign-up Page

Pembeli dan pelapak dapat melakukan sign-up dengan cara melakukan klik sign-up dan mengisi form berikut

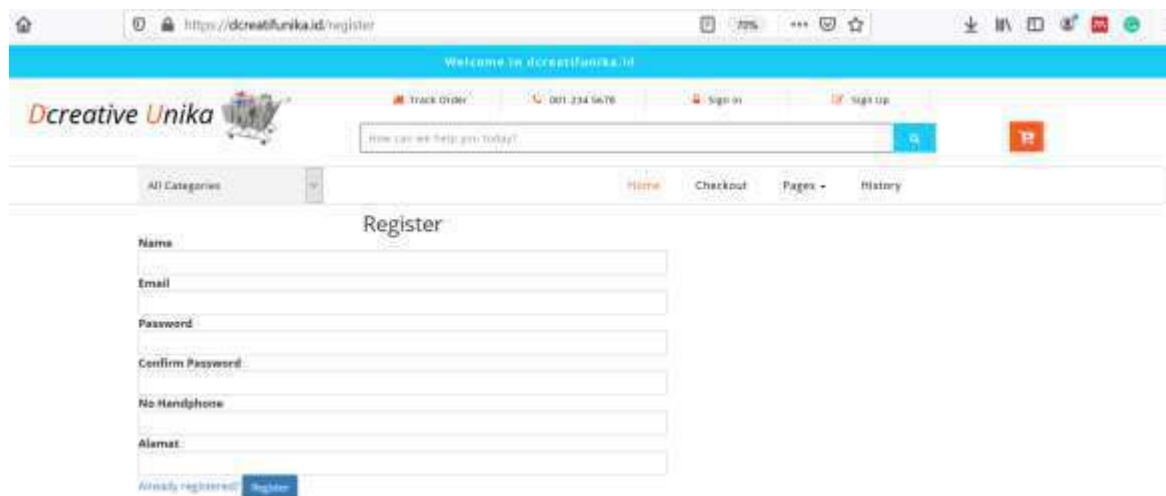

Figure 4. Sign-up Page

Semua text area wajib diisi, jika terdapat ada text area yang tidak diisi maka tidak dapat melakukan registrasi.

### Sign-in Page

Apabila sudah melakukan registrasi, maka user dapat melakukan sign-in menggunakan user email yang telah didaftarkan.

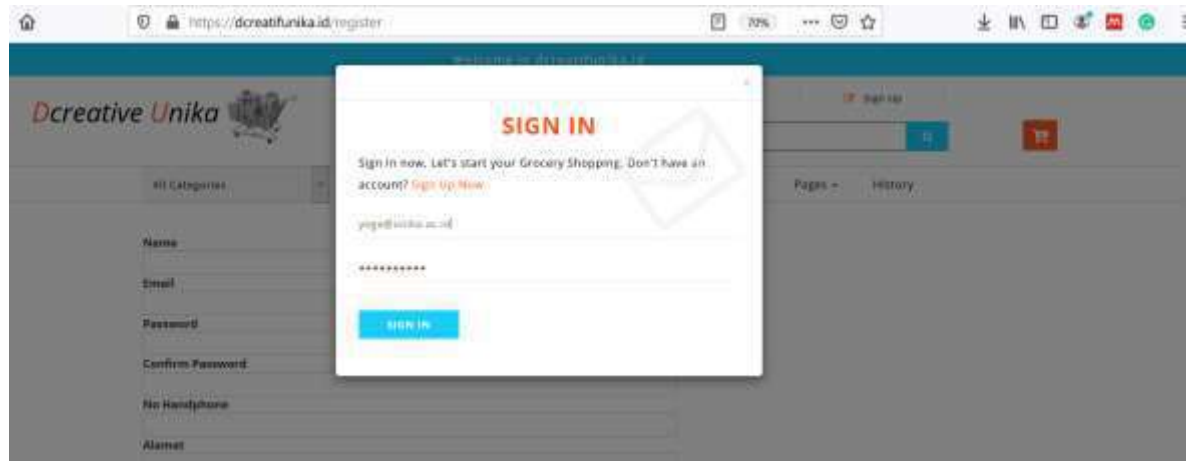

Figure 5. Sign-in Page

## Dashboard Page

Setelah login maka user melakukan pembelian, dengan melakukan klik button add to chart disetiap produk.

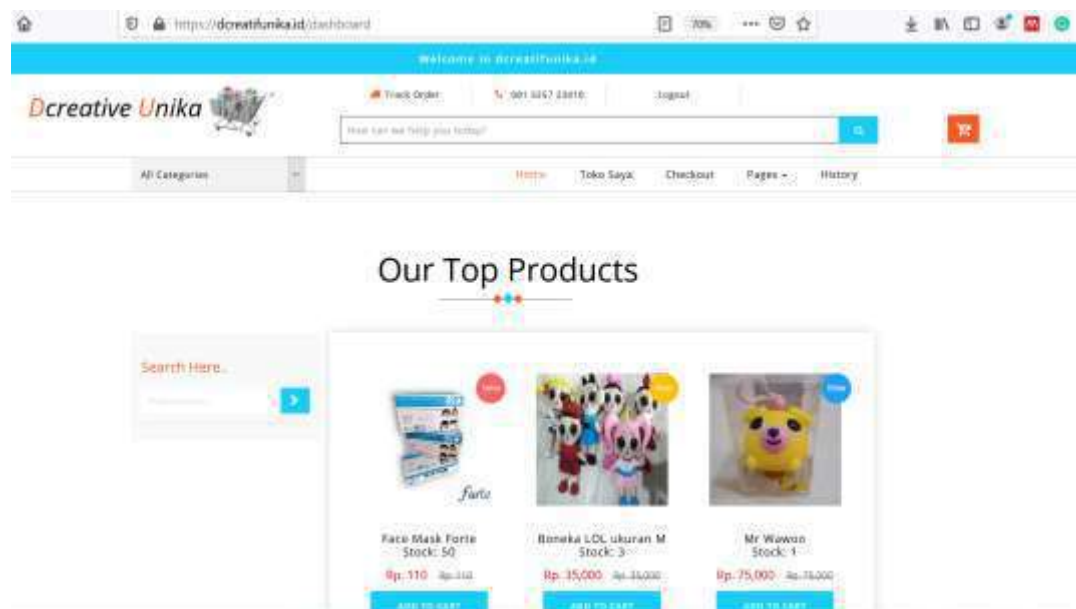

Figure 6. Dashboard Page

## B. Buyer Page

### Add to Chart

Setelah melakukan add to chart maka pembeli dapat memasukkan jumlah yang akan dibeli seperti terlihat pada gambar dibawah ini. Setelah memasukkan jumlah pembelian, lalu menekan tombol add to chart untuk Kembali ke menu/tampilan awal.

## Detail Produk



Figure 7. Add to Chart Page

## Check out Page

Terlihat tampilan checkout seperti pada gambar dibawah ini.

## Checkout



Figure 8. Check Out Page

## Add Shipping Detail

Menginput data pengiriman

**Add Shipping Details**

Full Name

Mobile Number

Postcode

Pilih Provinsi

Pilih Kota

Kecamatan

Street Address

Email Address

Notes about your order, e.g. special notes for delivery.

Checkout [Lanjutkan Selanjut](#)

Figure 9. Add Shipping Detail Page

## C. Seller Page

### Registering Online Shop

Mendaftarkan toko dapat dilakukan jika telah melakukan registrasi dan login. Setelah login maka akan terlihat seperti pada gambar dibawah ini. Gambar yang digaris bawah merah akan muncul.

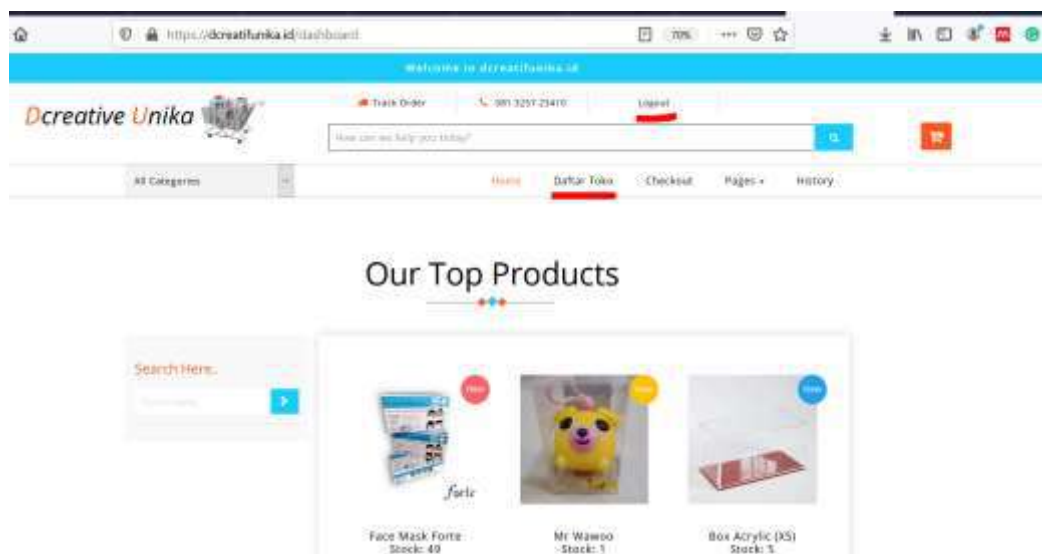

Figure 10. Register Page

Untuk Mendaftarkan toko lakukan Klik daftar toko, dan akan diminta untuk mengisi form seperti dibawah ini:





Figure 11. Add Shop Detail Page

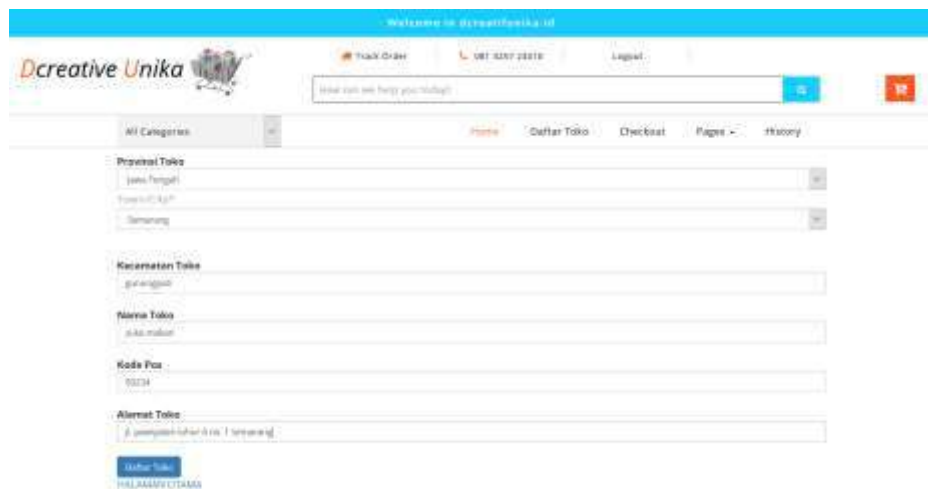

Figure 12. Registering Shop Detail

Setelah diisi lengkap klik tombol daftar toko, dan akan muncul toko saya (digaris bawah), didalam toko saya tersebut pelapak dapat mengisi barang yang akan dijual.

Setiap pelapak hanya diperbolehkan mendaftarkan 1 toko.



Figure 13. Online Shop URL

Setelah tombol Toko saya di klik, maka akan terlihat seperti pada gambar dibawah ini. Anda dapat mengupload produk yang akan dimasukkan dalam sistem ini dengan melakukan klik tombol upload product.

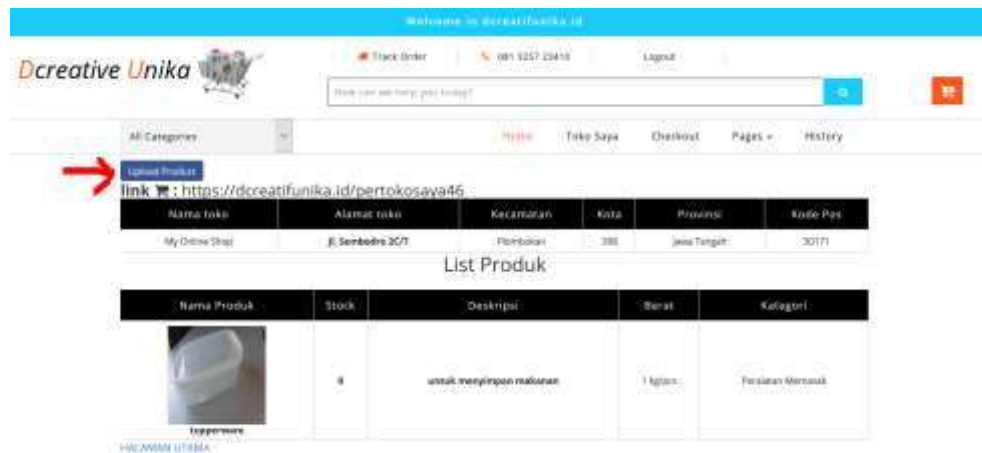

Figure 14. My Shop Page

Setelah klik tombol upload produk, anda dapat mengisi spesifikasi produk dan fotonya. Lengkapi semua isian dan klik browse untuk memilih foto yang akan di upload, seperti terlihat pada gambar dibawah ini

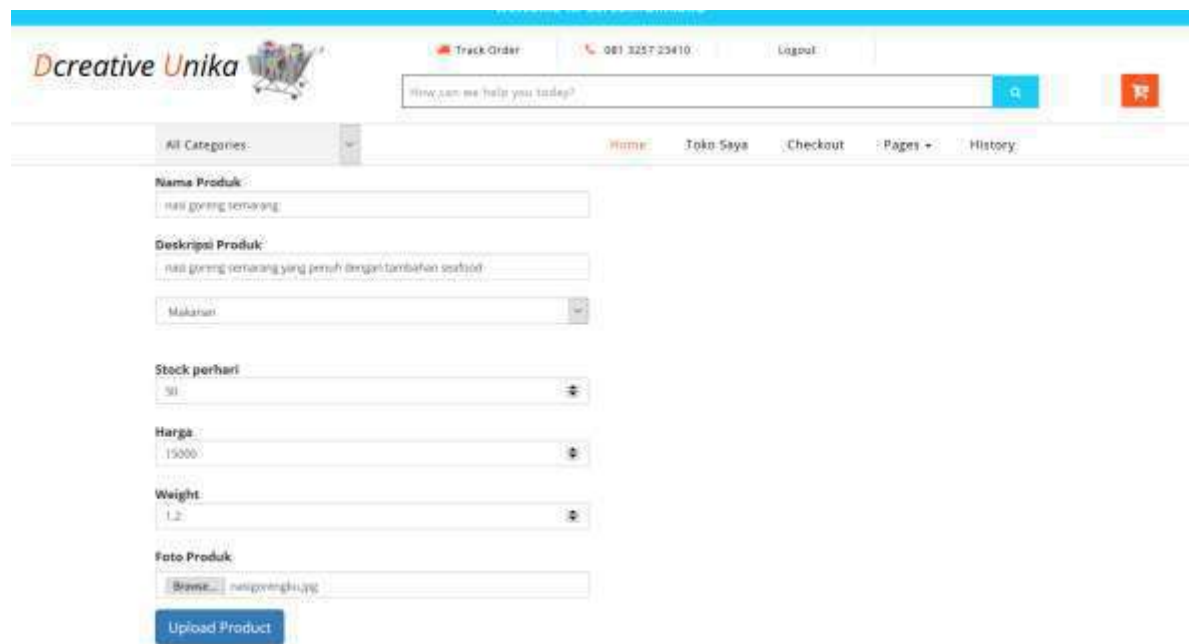





Figure 15. Upload Product Detail Page

Setelah klik upload produk akan terlihat seperti pada gambar dibawah ini. Akan tampil daftar produk yang telah kita upload.

https://dcreatifunika.id/tokosaya

### List Produk

Nama Produk	Stock	Deskripsi	Berat	Kategori
 tupperware	0	untuk menyimpan makanan	1 kg/pcs	Peralatan Memasak
 nasi goreng	90	nasi goreng lampung	1 kg/pcs	Makanan
 nasi goreng ruwet	50	nasi goreng ruwet ala kadarnya	1.5 kg/pcs	Makanan
 nasi goreng semarang	90	nasi goreng semarang yang penuh dengan tambahan seafood	1.2 kg/pcs	Makanan

HALAMAN UTAMA

Figure 16. List of Product Page

Ketika kita menekan tombol HALAMAN UTAMA, maka produk kita akan tampil dihalaman depan berpagung dengan produk-produk dari pelapak yang lain.

https://dcreatifunika.id/main

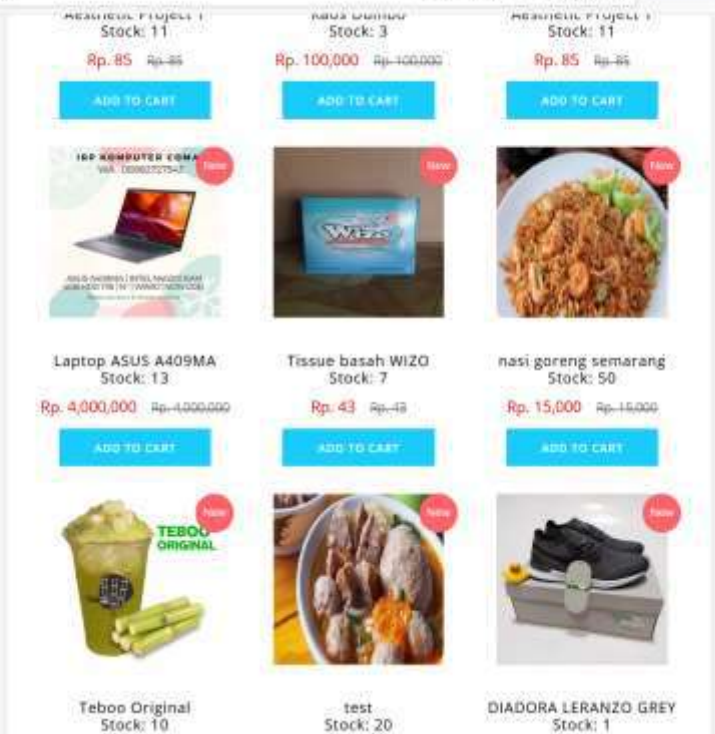

The main page displays a grid of products with the following details:

- HEALTHFUL FRUITLE 1**: Stock: 11, Price: Rp. 85 (discounted from Rp. 85)
- HEALTHFUL FRUITLE 1**: Stock: 3, Price: Rp. 100,000 (discounted from Rp. 100,000)
- HEALTHFUL FRUITLE 1**: Stock: 11, Price: Rp. 85 (discounted from Rp. 85)
- ISP KOMPUTER COMA**: Stock: 13, Price: Rp. 4,000,000 (discounted from Rp. 4,000,000)
- Tissue basah WIZO**: Stock: 7, Price: Rp. 43 (discounted from Rp. 43)
- nasi goreng semarang**: Stock: 50, Price: Rp. 15,000 (discounted from Rp. 15,000)
- Teboo Original**: Stock: 10, Price: Rp. 15,000 (discounted from Rp. 15,000)
- test**: Stock: 20, Price: Rp. 15,000 (discounted from Rp. 15,000)
- DIADORA LERANZO GREY**: Stock: 1, Price: Rp. 15,000 (discounted from Rp. 15,000)

Figure 17. My Product on Main Page

# DOKUMEN HASIL UJI COBA PRODUK LUARAN PENELITIAN PTUPT - 2020

Kementerian Riset dan Teknologi/Badan Riset dan Inovasi Nasional

## Judul Penelitian:

Model dan implementasi Industri Kreatif Digital Berbasis Adopsi Teknologi Informasi Generasi Y dan Z

## Nama Produk:

WEBSITE E-Marketplace *dcreatifunika.id*

## Peneliti:

1. Bernardinus Harnadi, Ph.D.
2. Albertus Dwiyoga Widiyanto, S.Kom., M.Kom.
3. Fx. Hendra Prasetya, ST., MT.

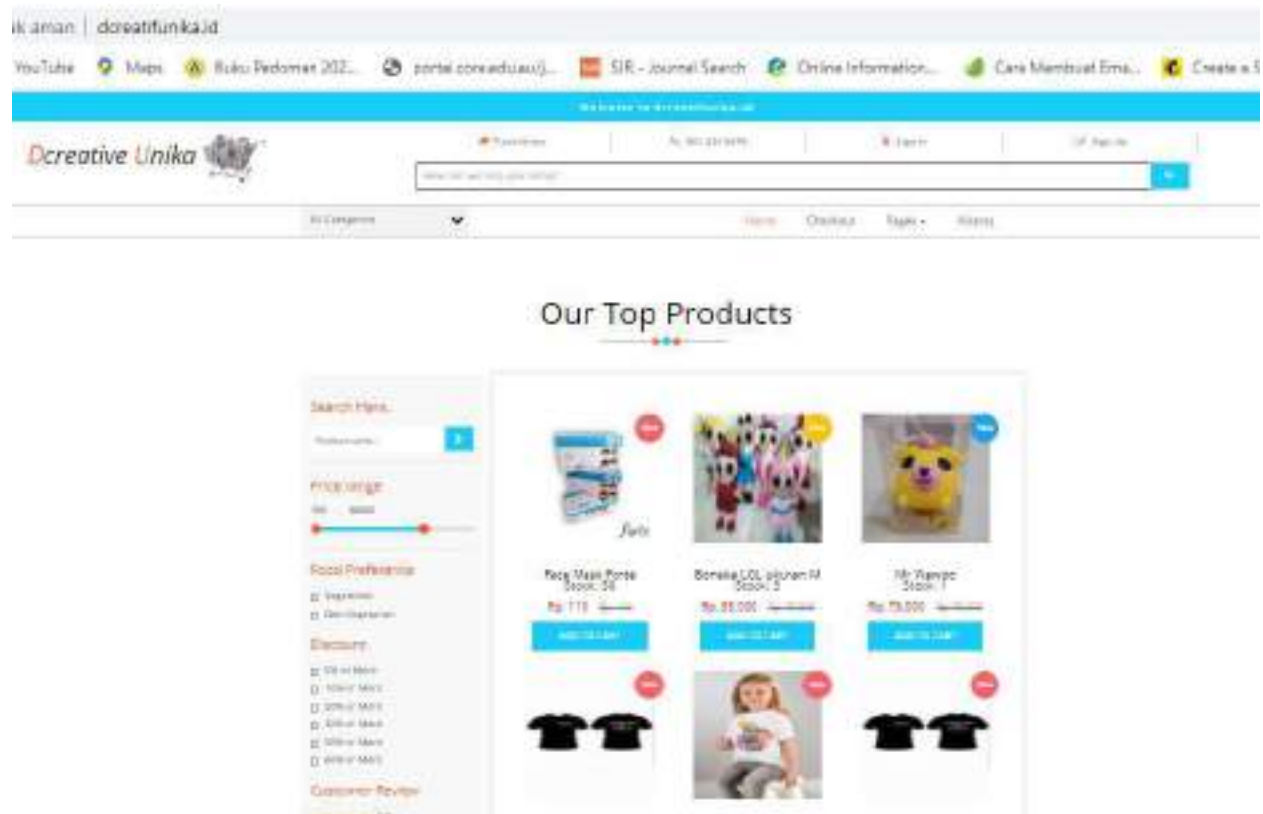

# DAFTAR PENGUJIAN

<b>I. UJI COBA PRODUK TAHAP-I</b>	.....	1
<b>Pelaksanaan: 7 November 2020</b>		
<b>Peserta: Pelaku E-Marketplace (penjual/pelapak)</b>		
Daftar Peserta Pengujian	.....	1
Link rekaman pelaksanaan pengujian	.....	2
Pengukuran “Technology Readiness Level” dari Responden	.....	2
Hasil dokumentasi Pengujian Tahap 1	.....	2
<b>II. UJI COBA PRODUK TAHAP-II</b>	.....	12
<b>Pelaksanaan: 26 November 2020</b>		
<b>Peserta: Pelaku E-Marketplace (penjual/pelapak)</b>		
Daftar Peserta Pengujian	.....	12
Link rekaman pelaksanaan pengujian	.....	12
Pengukuran “Technology Readiness Level” dari Responden	.....	12
Hasil dokumentasi Pengujian Tahap 1	.....	12
<b>III. UJI COBA PRODUK TAHAP-III</b>		
<b>Pelaksanaan: 26 November 2020</b>		
<b>Peserta: Pelaku E-Marketplace (pembeli)</b>		
Daftar Peserta Pengujian	.....	15
Link rekaman pelaksanaan pengujian	.....	16
Pengukuran “Technology Readiness Level” dari Responden	.....	16
Hasil dokumentasi Pengujian Tahap 1	.....	16
LAMPIRAN	.....	22

## I. Hasil Pengujian I WEB E-Marketplace dcreatifunika.id 7 Nov 2020

### Daftar Peserta Pengujian:

No	Nama	Email	Status	Usia	Gender
1	Scolastika Merryana Christa Dini	20n10031@student.unika.ac.id	Mahasiswa	19 tahun	Wanita
2	RM Dionisius Haryokusumo	rewascope@gmail.com	Mahasiswa	21 tahun	Pria
3	Axell Victoryan Nugroho	axellndut@gmail.com	Mahasiswa	18 tahun	Pria
4	David Kresna Husodo	20n10003@student.unika.ac.id	Mahasiswa	17 tahun	Pria
5	Benedikta Avien Ardyani	20n20002@student.unika.ac.id	Mahasiswa	18 tahun	Wanita
6	David Marcelino	20n40006@student.unika.ac.id	Mahasiswa	18 tahun	Pria
7	Jason Brilly Karunia	20n10022@student.unika.ac.id	Mahasiswa	18 tahun	Pria
8	Immanuel Agus Erlangga	erlanggaaaaaa@gmail.com	Mahasiswa	20 tahun	Pria
9	TEOFILUS GAGAH VESTIANNADA	20n10032@student.unika.ac.id	Mahasiswa	19 tahun	Pria
10	Ong Vincent Indra Purnomo	20n10016@student.unika.ac.id	Mahasiswa	18 tahun	Pria
11	Ernest Kristianto Swandana	20n10017@student.unika.ac.id	Mahasiswa	17 tahun	Pria
12	Qosda Muhdi Umar Umay	ricardwufireeargh@gmail.com	Mahasiswa	18 tahun	Pria
13	Raymond Christian Valentino	20n10011@student.unika.ac.id	Mahasiswa	17 tahun	Pria
14	Michae Anthony N	<a href="mailto:20n40004@student.unika.ac.id">20n40004@student.unika.ac.id</a>	Mahasiswa	18 tahun	Pria
15	Failla Soffie	20n40012@student.unika.ac.id	Mahasiswa	18 tahun	Wanita
16	William Ong Listijono	20n10006@student.unika.ac.id	Mahasiswa	18 tahun	Pria
17	Edward Winata Sugianto Putra	20n20001@student.unika.ac.id	Mahasiswa	17 tahun	Pria
18	Oei Evan Prasetyo	20n10009@student.unika.ac.id	Mahasiswa	18 tahun	Pria
19	Laurensius Aldo	20n40001@student.unika.ac.id	Mahasiswa	18 tahun	Pria
20	Dionnisius Luky Pratama	19n10021@student.unika.ac.id	Mahasiswa	19 tahun	Pria
21	C.Oktoriananda L.N.	20n40011@student.unika.ac.id	Mahasiswa	18 tahun	Wanita
22	Michael Cecchinello Prasetyo	20n20006@student.unika.ac.id	Mahasiswa	19 tahun	Pria
23	Albertus Christ Dwi Kurniawan	20n10004@student.unika.ac.id	Mahasiswa	18 tahun	Pria
24	Maxine	20n40010@student.unika.ac.id	Mahasiswa	18 tahun	Wanita
25	Marcelino Febrian Handana	20n10030@student.unika.ac.id	Mahasiswa	19 tahun	Pria
26	Nicholas Dwiki Tanoto	20n10007@student.unika.ac.id	Mahasiswa	18 tahun	Pria
27	Albertus Prido Nathanael	20n10021@student.unika.ac.id	Mahasiswa	18 tahun	Pria
28	Christian Kurnia Wardhana	20n40007@student.unika.ac.id	Mahasiswa	18 tahun	Pria
29	Hierro Megantara	17n10022@student.unika.ac.id	Mahasiswa	21 tahun	Pria
30	Vania Renata	20n20005@student.unika.ac.id	Mahasiswa	18 tahun	Wanita
31	Stanislaus michael s	20n40002@student.unika.ac.id	Mahasiswa	18 tahun	Pria
32	Dimas julio prima	dimasjulio01@gmail.com	Mahasiswa	19 tahun	Pria
33	Benedicta Nathania Nugroho	20n10023@student.unika.ac.id	Mahasiswa	18 tahun	Wanita
34	Syifa khofifah	Syifakhofifah02@gmail.com	Mahasiswa	18 tahun	Wanita
35	Michael Samuel kueain	20n10025@student.unika.ac.id	Mahasiswa	18 tahun	Pria

No	Nama	Email	Status	Usia	Gender
36	Daniel Eka Pratama Sanjaya	20n10008@student.unika.ac.id	Mahasiswa	18 tahun	Pria
37	Fernando Setiawan	20n10005@student.unika.ac.id	Mahasiswa	17 tahun	Pria
38	Annisa Dwi Amalia	anispersen2002@gmail.com	Mahasiswa	18 tahun	Wanita
39	Lisna Noviati	20n10018@student.unika.ac.id	Mahasiswa	19 tahun	Wanita
40	alvin christian	20n10028@student.unika.ac.id	Mahasiswa	18 tahun	Pria
41	Abednego Wijaya Adiwibowo	20n10014@student.unika.ac.id	Mahasiswa	18 tahun	Pria
42	Adolf Patrick Lengkong	20N20003@student.unika.ac.id	Mahasiswa	17 tahun	Pria
43	Benedictus Brian Renaldi Darmawan	17n10020@student.unika.ac.id	Mahasiswa	21 tahun	Pria
44	awaludin latif faizin	20n40013@student.unika.ac.id	Mahasiswa	20 tahun	Pria
45	Natasha Diva Muljono	20n10012@student.unika.ac.id	Mahasiswa	18 tahun	Wanita
46	Natalia Diva Muljono	20n10013@student.unika.ac.id	Mahasiswa	18 tahun	Wanita
47	Bellarmino Bintang Pradipta	20n10015@student.unika.ac.id	Mahasiswa	18 tahun	Pria
48	Yosef Pandu Hadi Wijaya	17n20009@student.unika.ac.id	Mahasiswa	> 21 tahun	Pria
49	Marcelino Febrian Handana	20n10030@student.unika.ac.id	Mahasiswa	19 tahun	Pria
50	Titus Theo Yoga Baskara	20n10019@student.unika.ac.id	Mahasiswa	19 tahun	Pria
51	Gouw, Owen Andrew Setiawan	20n10024@student.unika.ac.id	Mahasiswa	18 tahun	Pria
52	Ng Suvandi Prasetyo	20n10001@student.unika.ac.id	Mahasiswa	18 tahun	Pria
53	Annisa Dwi Amalia	anispersen2002@gmail.com	Mahasiswa	18 tahun	Wanita
54	Syifa khofifah	Syifakhofifah02@gmail.com	Mahasiswa	18 tahun	Wanita

Link rekaman pelaksanaan pengujian:

<https://drive.google.com/drive/folders/1AFFdE85fwRt9cjdPcG57xfSliho83V>

Pengukuran "Technology Readiness Index" dari Responden (skala 1 – 5):

1. Optimisme : 4.036363636
2. Inovasi : 3.695454545
3. Ketidaknyamanan : 2.868181818
4. Ketidakamanan : 3.563636364

Hasil dokumentasi Pengujian Tahap 1:

1. TENTANG TAMPILAN WEB E-Marketplace dcreatifunika.id

a). Pendapat

+ Positif

- fitur / tampilan pada web cukup memadai.
- Tampilan lengkap, dan mudah dioperasikan.
- tampilan tidak membosankan dan menarik dan enak dipandang
- Desain bagus, simple, dan rapih
- pemilihan warna yang sangat bagus
- Tampilan terlihat modern
- desainnya unik dan lucu buat e-marketplace
- penempatan gambar dan tulisan sudah rapi.

- bagus kreatif
- Tampilan home screen menarik dan atraktif,
- color grading bagus
- desain web unik dan berkesan meriah.
- Tampilan UI cukup mudah dimengerti dan dioperasikan
- inovatif dan menginspirasi
- tampilan web user friendly.
- Tampilan yang sederhana namun elegan
- Menu-menu dan tombol-tombol tertata dengan rapi dan gambar produk jelas
- tampilannya sederhana, etalase nya rapi,
- produk dan lain-lain juga tidak terlalu mepet dan detail,
- layout nya tidak terlalu ramai, bagus sudah tertata.
- tampilan sudah kekinian dan menarik

- **Negatif**

- kurang responsif
- tampilan kurang rapi dan menarik
- Terlalu monoton karna terlalu banyak white space pada tampilan awal web
- tampilannya kurang user friendly dan agak membingungkan.
- pada kolom banner masih kosong
- Tampilan web masih belum teratur pada bagian footer masih banyak page yang kosong saat di klik.
- Tampilan webnya sedikit membingungkan dan kurang responsif
- sedikit kebingungan saat mencari produk.
- terdapat beberapa button yang link nya tidak valid
- masih ada error dan beberapa menu masih belum bisa diakses dengan cepat

**b). Masukan**

- Perlu tambahan tampilan fitur yang lebih lengkap dan diberikan pembagian pengelompokkan lagi
- untuk pricelist produk lebih bagus jika diberi info soal produk tersebut
- Diberi jarak antar layout/ etalase nya agar terlihat lebih longgar dan produk terlihat dengan baik
- perlu dirapikan dan ditambahi tombol navigasi nya
- lebih ditambahkan fitur" lain dan tampilan lebih dibuat menarik lagi
- ganti warna background jangan kebanyakan warna putih
- Memperbaiki tampilan email akun yang login karena tadi saat uji coba, ketika login dengan akun pribadi, ketika di home, akun login yang tampil bukan email akun pribadi kita tapi email orang lain, mengisi kekosongan white space dengan elemen-elemen tertentu
- Kalau bisa di perunik lagi agar lebih menarik, dan lebih berwarna
- Mungkin sistem nya lebih dibenerin, jadi semisal <http://dcreatifunika.id/tokosaya> dibenarkan agar bisa seperti ini, contoh <http://dcreatifunika.id/bysoffie> agar langsung bisa membuka tokonya
- Layout dibuat lebih menarik dan tombol di perbesar agar membuat user experience lebih bagus. Juga tampilan tema di tambah agar tidak berkesan kosong.
- beri konten promo/diskon yang menarik pada kolom banner
- dapat menampilkan produk produk yang sesuai dengan minat dari pengguna
- Kalau bisa produk yg direkomendasikan langsung muncul di bagian home, tidak perlu discroll, dan diberi desain/gambar agar tidak terlalu polos.



- tambahkan gambar" atau warnanya agar tidak terlihat terlalu kaku dan monoton
- beri logo iconic di home pagenya
- Ditampilan main kalau bisa dikasih batasan barang yang ditampilkan dan fitur sorting seperti dari harga termurah-mahal, dll. Agar tampilan tidak berantakan
- Memberi logo website tersebut agar lebih cantik.
- tambahkan tata cara menggunakan web tersebut
- jika ada kesalahan input seperti yang dibagian numbers only sebaiknya diberi notifikasi dan jangan dibawa ke code nya
- diberi tampilan warna warna yang mencolok seperti ungu
- pewarnaan lebih diutamakan agar web terlihat lebih meriah namun tetap tidak membingungkan customer
- masih harus diperbaiki lagi webnya dan user interface lebih dibikin mudah untuk digunakan
- Diperbaiki UI nya supaya orang lebih mudah mengakses
- Di beri rekomendasi barang serta bisa tambahkan saldo mungkin di layar home
- bagian footer web dibuat lebih simple lagi
- dipermudah dari segi akses web tersebut, deskripsi barang/produk agar terlihat rapi dan menarik, bagian daftar toko tampilannya/halamannya lebih dipermudah/simple
- untuk pemilihan provinsi, jumlah karakter yang bisa di input, mungkin bisa di revisi terutama untuk provinsi jika bisa langsung terdeteksi agar orang mudah saat input data.
- Tampilannya kalau bisa diganti secara berkala, agar pengunjung tidak bosan. Saran, ditambahkan sebuah fitur untuk mengganti desain webnya, dimana pengunjung bisa untuk memilih desain dari web yang diinginkan
- Di bagian saat memasukkan nama kota, mungkin lebih diringkas lagi sehingga tidak perlu scroll sampai ke bawah untuk mencari kota Semarang, mungkin lebih bisa ditambahkan fitur search pada kota.
- perlu perbaikan sedikit mengenai pencarian produk
- untuk warna mungkin lebih di kombinasikan
- bagian template yang tidak penting dihilangkan atau diedit
- ditambah daya tarik yang lebih mencolok
- lebih ditingkatkan lagi backgroundnya
- perbaikan link button, improvisasi layout web
- diluaskan kebalikannya soalnya kebanyakan klo di klik ga bisa di buka
- Dikasih gambar lebih banyak lagi agar tampilan web terlihat lebih menarik.
- perlu perbaikan sedikit mengenai pencarian produk

## **2. Tentang Desain Web E-Marketplace dcreatifunika.id yang responsive**

### **a). Pendapat**

#### **+ Positif**

- tampilan layout konten cukup menarik
- Desain sudah bagus, sangat menarik dan juga keren, efisien
- desain webnya terkategori dengan baik.
- web cukup responsive (~ 2s load time), mobile friendly
- layout konten dan splash screen yang dibuat sudah baik
- desainnya bagus unik dan bikin orang tidak bosan, nyaman di gunakan.
- Desain yang modern, simple, elegan, bagus tertata dengan rapi, kreatif

- perpaduan aksesoris warna hijau dan hitam untuk font huruf sudah cocok, dan enak dipandang mata, layout sudah ditata dengan baik
- Splash screen saat mengklik tombol cukup responsive. Loading screen saya tadi cukup cepat. Tampilan splash screennya juga simple dan enak dipandang.
- cukup sederhana namun menarik
- Sudah Responsive
- pemilihan warna hijau putih yang kalem dan tampak ramah
- tampilan splash screen sudah oke tidak ada lemot, tampilan konten cukup bagus dan mudah dibaca

#### **- Negatif**

- kurang menarik perhatian, tampilan kurang menarik
- banyak button yang tidak responsive, button tidak dapat diklik, dan button yang menghalangi kenyamanan shopping
- masih kurang responsive
- layout konten masih butuh pengerjaan dan perbaikan, desain yang sekarang ini masih kurang mudah untuk dipahami, splash screen sudah cukup baik.
- layout pada "toko saya" bagian alamat toko terlalu memakan tempat
- splash screen terlalu lama.
- layout kontennya sudah bagus dan splash screennya juga
- layout template yang terdapat pada website masih banyak yang perlu diperbaiki seperti header website yang tidak dapat diklik, (contoh: akun sosial media di bagian atas website, Kategori barang,)
- untuk tampilan awal agak di buat tulisan register, home dan sign-in bisa di buat agar orang mudah melihat agar efektif.
- layout konten bagian deskripsi produk jangan terlalu menurun kebawah
- Desain web kurang menarik karena terkesan polos.
- Sudah terlihat baik namun banyak layout yang terlihat kosong
- terlalu banyak warna putih
- masih banyak link yang masih belum bisa dipakai
- Web bermasalah saat mendaftarkan toko saja.

#### **b). Masukan**

- Diberikan desain dengan warna hitam agar terlihat lebih elegan dan bisa ditambahkan gambar terkait agar lebih menarik, dan mengangkat lagi.
- untuk kategori toko lebih diperkaya lagi, seperti halnya penjualan di bidang jasa
- tampilan sebaiknya tidak terlalu polos, mungkin bisa ditambahkan beberapa logo atau widget agar tidak terlihat sepi
- Lebih diperbanyak lagi variasi unsur desain pada layout
- dibuat menarik perhatian konsumen agar betah untuk mencari barang yang akan dibelinya
- untuk button bisa dibenahi kembali agar berfungsi
- Bisa dibuat lebih berkelas dan menarik lagi
- perlu ditingkatkan lagi agar web dapat lebih responsive
- gunakan warna lain backgroundnya agar tidak bosan
- Bisa ditambahkan gambar-gambar pada setiap kategori produk supaya mengisi white space yang kosong
- dalam splash screen jangan terlalu besar agar tidak terlalu memenuhi layar

- Sistemnya tolong dibenarkan agar tidak terjadi error/bisa juga tidak masuk
- List produk dalam toko dibuat lebih rapi atau diatur ke dalam blok-blok agar terkesan rapi dan profesional, pemilik toko juga akan dipermudah dalam mengatur produk tokonya.
- mungkin bisa mengganti layout nya
- mungkin bisa di tambah konten-konten original sendiri seperti maskot atau logo, tidak perlu diberi splash screen karena bagi sebagian orang splash screen membuat risih karena biasa lemot
- Splash screen kalau bisa pakai timer saja jadi tidak harus menekan tombol "home", Dan splash screen agak dicecilin biar gak terlalu memenuhi layar
- bagian useful link tambahkan link-link yang diarahkan ke konten-konten tersebut
- Mungkin nomor telfon "+65 11.188.888" dan e-mail "17n10004@student.unika.ac.id" tidak usah ditaruh di atas page karena di bawah page sudah ada. Waktu splash screen mungkin bisa dikurangi.
- splash screen nya dibuat lebih unik lagi
- lebih dipercepat dalam upload
- tampilan diberi animasi saat loading
- masih ada minor minor yang nggak perlu diakses
- "Bisa diberi tema sesuai keinginan masing2
- Bisa di tambahkan lagi fotonya tidak hanya foto sayuran, splash screen mungkin bisa di rapikan lagi
- Jika tidak digunakan sebaiknya tombol, pages, dan link yang tersedia pada website dihapus agar tampilan web bisa lebih simple. (contoh : usefull link bagian paling bawah, Iklan dari tempelate bawaan blog yang tidak berfungsi)
- untuk penempatan tombol yang mudah untuk di cari dan di lihat.
- Sedikit diberi hiasan mungkin?? karna terlalu polos hanya warna
- Mungkin sedikit di tambahkan beberapa menu yang menarik agar pengguna penasaran dan mencoba ini
- loading screen yang cukup lama, kurang stabil
- perlu ditingkatkan lagi kecepatannya
- lebih baik bagian deskripsi produk dibuat lebih horizontal, agar calon customer lebih nyaman membaca deskripsinya
- Untuk layout dalam memilih kota semoga dapat diperbaiki, karena pada saat memilih kota layarnya terlalu ke bawah sehingga agak membingungkan. Lalu bagian pada saat mengisi bagian deskripsi produk tidak bisa di enter, semoga dapat diperbaiki sehingga tulisan menjadi lebih tertata dan rapi. Selain itu pada bagian tampilan deskripsi produk menurut saya lebih baik memanjang supaya orang yang membaca lebih enak.
- warna bisa di tambahi lagi biar ga hijau putih saja
- Gunakan warna yang lebih bervariasi agar website terlihat lebih menarik.
- Sedikit diberi hiasan mungkin?? karna terlalu polos hanya warna

### **3. Tentang Fungsionalitas Website E-Marketplace dcreatifunika.id**

#### **a). Pendapat**

##### **+ Positif**

- Fungsionalitas pada web sudah berjalan dengan sangat baik dan lancar, Untuk register dan login cukup mudah, sudah baik dan cepat, data yang keluar sesuai dengan data yang kita input
- cukup mudah untuk membuat akun ,menu sudah cukup komplit.
- cukup mudah diakses, Semua fitur yang ada di dalam berguna dengan baik
- fitur log in dan register dari dcreatif sudah cukup bagus menurut saya

- mudah di gunakan, sudah cukup jelas, bagus dan baik
- Mudah untuk dipahami bagi pemula
- Cara login/register cepat dan mudah, verifikasi email tidak rumit

#### - Negatif

- ada beberapa menu yang tidak merespon jika diklik (kategori, filter pencarian)
- Buruk, Sangat Kurang, ada beberapa fungsi yang belum lengkap
- "ada bug pada saat register verify email, bingung saat mau masuk, masuk susah nya pas dapat email
- registernya terlalu lama, harus verifynya nunggunya lama, agak kesulitan saat verify email, verifikasi yang tidak terkirim
- Laman login dan register sudah berfungsi dengan baik, namun jika traffic tinggi agak error, mungkin desain laman login dan register bisa dibuat lebih menarik, laman menu juga layout nya agak aneh dan kurang rapi.
- belum bisa ngehapus product yang sudah di upload
- menunya yang sulit ditemukan
- kesulitan saat mendaftarkan toko. Saya kira " Daftar Toko " itu berisi list toko - toko yang ada di sini.
- Kendala saat login pada saat verifikasi yang terdapat eror jika email yang kita gunakan diganti. dan feature search product yang tidak berfungsi.
- fungsionalitas websitenya kurang maksimal
- Masih sangat lambat dan juga sering error hanya kadang kadang bisanya
- beberapa fitur missing
- masih ditemukan beberapa bug saat mengupload product

#### b). Masukan

- menu untuk kedepan nya bisa di tambahkan pulsa mungkin atau pln seperti market place lain
- Penambahan fungsionalitas yang lebih bermacam-macam dan peningkatan kualitas.
- pada bagian isian nama toko hanya tersedia sedikit karakter huruf untung digunakan, sehingga jika ada yang memiliki nama toko panjang akan sedikit susah. Pada bagian isian kota toko menggunakan kode angka pada hasilnya, sehingga pada info kota toko berisikan kode angka. Pada bagian upload foto produk juga hanya dapat mengunggah 1 foto
- mohon dilengkapi menunya, salah satunya pilihan blog details
- ada crash di fungsionalitas web "dcreatif"
- lebih dilengkapkan lagi dalam fungsi seperti pilihan berat produk, penggunaan simbol / emoticon untuk memperindah penampilan
- bug nya dibenahi kembali agar dapat diakses dengan mudah, banyak error disana sini
- ditambahkan fitur fitur yang lebih user friendly
- verifikasinya lebih enak menggunakan nomor hp yang didaftarkan
- dalam hal register terkadang tidak mendapatkan email verifikasi
- Seharusnya memakai nomer hp saja untuk kode terverifikasi atau belum karena lebih gampang
- Menu utama dibuat lebih rapi dan langsung menampilkan produk-produk yang laris atau sedang promo agar pengguna tertarik dan lebih sering mengunjungi website.
- beri customer service 24/7
- mungkin dapat dikembangkan lagi fitur login agar dapat menggunakan 2 factor authentication
- Saat akan konfirmasi email, lebih baik jika muncul layar seperti "Email berhasil diverifikasi", karena tadi bingung antara error, harus coba lagi, atau belum diverifikasi.
- perbaiki masalah yang terjadi pada saat ingin register dan bagian productnya

- dipermudah cara loginnya, kendala verifikasi saat register
- Kalau bisa dibagian myshop ditambahkan agar tidak cuma melihat toko sendiri, tetapi bisa melihat toko yang lain dan produk-produk yang mereka pasang
- Pada register terdapat banyak orang yang tidak dapat e-mail untuk verifikasi. Department Menu mungkin bisa ditambah dan dijadikan satu misalnya saya lihat ada pilihan elektronik dan pilihan teknologi, lebih mending dijadikan satu "Elektronik dan Teknologi" dan menambahkan seperti "Hobby" dan lain-lain karena saya tidak tau mau memilih department yang mana untuk produk saya.
- sebaiknya button menu harus ditulis menu dengan jelas
- saat melakukan register, tampilan saat memasukan kota mohon untuk bisa diketik dan muncul kota asal pemilik tersebut agar pemilik toko tidak harus mengscroll hingga bawah untuk mencari. dan mohon diperbaiki agar bisa mengsupport agar nama toko yang panjang bisa teraccept oleh sistem tidak error
- Tombol daftar toko dikluarkan dari bar home dll, atau diberi " Belum memiliki toko? Daftar Toko(dapat diklik) "
- Perbaiki sistem untuk register dan login agar jika ada pembeli dan penjual tidak mengalami kesulitan untuk register, banyak orang yang tidak mendapatkan email verifikasi saat register.
- sebaiknya akses web ini diperbesar, tingkatkan lagi koresponsifitasnya
- buat pilihan yang bervariasi seperti login dengan facebook
- di menu registrasi ditambahkan beberapa entri pertanyaan untuk data diri.
- Pada bagian history tidak berfungsi, bagian pesanan di menu admin juga belum berfungsi. dan tidak dapat mengedit produk.
- dari segi fungsionalnya terlalu biasa
- menurut saya seharusnya ada pilihan untuk menambahkan warna, ukuran, dan bisa menambah lebih dari 1 foto
- bagian untuk upload produk dapat ditingkatkan lagi supaya bisa mengupload satu produk dengan berbagai warna. Dan ditambahi item lainnya sehingga lebih menarik
- penambahan fitur edit produk
- banyak orang yang kesulitan masuk ke web tersebut
- Memperbaiki kecepatan web nya agar lebih nyaman dipakai

#### **4. Tentang Navigasi dalam Web E-Marketplace dcreatifunika.id**

##### **a). Pendapat**

##### **+ Positif**

- Navigasi web sudah berjalan cukup baik, jelas dan tidak membingungkan, mudah dimengerti dan digunakan
- Sudah bagus untuk pelayanannya cepat untuk menjangkau linknya juga cepat (tergantung emailnya)
- Simple, sudah cukup baik, cukup mudah dan nyaman
- baik dalam pelayanan dan penyediaan yang di perlukan konsumen
- sudah cukup lengkap dan detail

##### **- Negatif**

- beberapa tombol ada yang error dan sulit diakses
- Buruk, saya tidak melihat navigasi dimana
- kurang baik, masih agak membingungkan
- Navigasi saat upload product kurang detail, sehingga sering error saat akan upload product
- saat ada salah input data, tidak diberitahukan salahnya dimana

- Gak bisa search product & milih kategori
- url toko sendiri tidak muncul di atas
- untuk navigasi pada web masih ada beberapa yang kurang, harus di tingkatkan lagi penempatan navigasi nya
- penggunaan bentuk font yang masih terlalu tebal dan besar (terutama pada bagian myshop)
- Fungsi search belum bisa digunakan.
- untuk mengakses web nya masih agak lama
- masuk ke servernya masih agak lama kadang error
- navigasi cukup baik, namun beberapa ada yang tidak valid, beberapa tombol tidak memiliki fungsi/tidak bisa dipencet.

#### **b). Masukan**

- Peningkatan navigasi lain untuk mempermudah melakukan transaksi.
- untuk pengalihan halaman menuju toko yang diinginkan jika tidak ada ,maka halaman hanya berkedip saja
- di kolom pilihan, sebaiknya diberi tombol scroll up horizontal agar halaman web tidak sampai panjang sekali ke bawah
- navigasi divariasikan lebih lagi agar menjadi lebih menarik
- Tombol search tidak berfungsi
- lebih ditingkatkan lagi agar lebih user friendly
- Memberi navigasi dengan detail pada setiap kolom yang harus diisi pengunjung agar tidak terjadi error
- Kalo bisa menjangkau lebih luas dibuat domain yang bisa orang masuk semua/memakai tanpa membuat lemot sistem
- Navigasi dibuat lebih mulus dan animasi yang menarik, fungsi tombol-tombol juga di lengkapi agar pengguna tidak bingung saat melihat-lihat website.
- beri arahan/peringatan jika ada salah data yang diinput
- mungkin dapat diberi filter lebih banyak lagi agar memudahkan navigasi barang yang ingin di cari
- Produk yang terfavorit direkomendasikan, tetapi juga diberi fitur seperti produk termurah, termahal, terbaru, dll. Dan juga diberi fitur range harganya
- buat url toko sendiri muncul di atas
- Pada toko saya, saya bingung ingin melihat dan men-copy link toko / produk saya.
- tadi saya sempat mencoba untuk mengedit produk saya namun malah dikirim ke home, dan juga sebaiknya menurut saya upload produk dan edit produk dan lain lainnya yang berhubungan dengan toko di tempatkan di my shop dan juga tulisan myshop harus dipisah
- semoga tidak ada error masuk kedalam halaman
- url untuk kreasinya belum susai
- Ketika sudah mencari barang,tombol Barang favorit di tampilkan lalu tombol seller dengan rating tertinggi di tampilkan serta ada tombol untuk harga tertinggi dan terendah
- font bisa diganti dengan yang lebih simple agar membuat tampilan terlihat lebih rapi.
- lebih di permudah dalam akses masuk web ini
- produk yang di uploud kurang bisa tertata rapi
- Mungkin bisa ditambahkan animasi dalam menu navigasi.
- cocok buat orang yang suka hal yang langsung tertuju
- diharapkan dapat lebih cepat saat mengakses webnya
- Ada beberapa yang error

- perbaikan link navigasi
- akses untuk webnya di perbaiki
- produk yang di upload kurang bisa tertata rapi

## 5. Tentang Performa Web E-Marketplace dcreatifunika.id

### a). Pendapat

#### + Positif

- Performa sudah cukup memuaskan karena memiliki kecepatan upload yang cukup dan penyangangan konten yang memuaskan.
- untuk kecepatan upload sudah cukup cepat, web ini mempunyai performa yang sudah cukup baik
- Sudah bagus,semisal mau masukin sesuatu sudah ditulis cara/kalimatnya
- lancar dan nyaman di gunakan, saat pemakaian tidak banyak yang di butuhkan
- peforma web cukup baik, sangat cepat dan cukup responsive
- UI daftar produk rapi dan baik di lihat

#### - Negatif

- Performa kecepatan saat mengupload gambar dan sign in kurang cepat
- terlalu lambat, diklik beberapa kali baru merespon
- Tidak bisa upload
- kecepatan yang sedikit lag dan lemot
- masih sangat lambat, Masih kurang stabil, sering terjadi bug dan error, dan kesan berat saat menggunakan web
- performa web masih jelek, sangat lemot dan bagian upload kurang jelas
- masih sering down
- loading sedikit agak lama, tapi mungkin gara-gara tadi banyak yang buka sekaligus
- untuk performa kurang cepat, untuk berpindah dari home ke my profil waktunya lama
- Kurang cepat dalam hal upload, tadi saya mengalami error
- Saat loading page masih lambat
- dalam mengupload foto/gambar produk hanya diberi 1 gambar saja, namun dibagian tayangan konten terlalu kecil penempatannya
- Kecepatan upload sangat lambat dan sering error servernya
- Performa web cukup baik, namun saat traffic tinggi, website bisa trouble dan menjadi sangat lemot.
- sedikit susah saat upload product

### b). Masukan

- peningkatan terhadap performa, kecepatan, dan kinerja web.
- lebih baik jika dapat mengupload foto produk lebih dari 1
- Kedepanya diperbaiki lagi agar tidak crash saat mengupload barang
- lebih ditingkatkan kembali performanya untuk upload file - file yang lebih besar
- sebaiknya penataan produk lebih rapi lagi
- Loading webpage cepat
- Memperbaiki kestabilan dan bug-bug tertentu seperti SQL State dan semacamnya
- dalam memasukan data produk masi rumit terkadang eror
- dikasih pilihan saja agar di sistem juga tidak bingung di pelaku e marketnya juga tidak bingung

- Kapasitas server di tingkatkan sehingga dapat meng-handle traffic yang lebih banyak, sehingga pelanggan bisa dengan leluasa mengakses kapanpun.
- upgrade bandwidth, upload yang dilakukan sering gagal karena server yang penuh.
- mungkin di kembangkan lagi coding di bagian upload
- Jika input file salah (contoh 0,5 harusnya 0.5), lebih baik diberi notifikasi error & tidak bisa diupload, karena jika diupload nanti akan muncul error & bikin bingung
- ada notif barang sudah berhasil terupload
- Server di tingkatkan lagi, search belum bisa di pakai, lalu ketika mengupload produk harga kalo bisa lebih spesifik lagi lalu berat bisa di tambahkan gram mungkin, barang yang sudah di upload belum bisa di edit, dan mungkin jangan lupa fitur free ongkir karena semua market place sudah mulai mengadakan free ongkir
- pengguna web ini lebih diberi kebebasan (memberi pilihan warna , desain tulisan/ tampilan produknya, dll) , bagian tampilan/tayangan konten lebih luas agar terlihat lebih rapi agar tidak membingungkan
- diperbaiki lagi upload file nya
- untuk performa mungkin harus ditingkatkan lagi, karena jika web dibuka secara bersamaan oleh banyak orang, servernya down
- Web loadingnya lama padahal sinyal bagus
- kembangkan lagi dibagian yang konten



## II. Hasil Pengujian II WEB E-Marketplace dcreatifunika.id 26 Nov 2020

### Daftar Peserta Pengujian:

No	Nama	Email	Status	Usia	Gender
1	Evangeline Eunike	19n40001@student.unika.ac.id	Mahasiswa	19	Wanita
2	Edward Galang Wibowo	19n40002@student.unika.ac.id	Mahasiswa	19	Pria
3	Te Boo Boo	tebooboo05@gmail.com	Mahasiswa	19	Wanita
4	Yehuda Joy Muljanto	19n40003@student.unika.ac.id	Mahasiswa	19	Pria
5	Emmanuel Evan	19n40005@student.unika.ac.id	Mahasiswa	19	Pria
6	Kenny Gavriel Susanto	19n40006@student.unika.ac.id	Mahasiswa	19	Pria
7	Maria Kineta	19n40012@student.unika.ac.id	Mahasiswa	> 21	Wanita
8	Michael Hans Christian P	19n40008@student.unika.ac.id	Mahasiswa	> 21	Pria

### Link rekaman pelaksanaan pengujian:

<https://drive.google.com/drive/folders/1AFFdE85fwRt9cjdPcG57xfSlihjo83V>

### Pengukuran "Technology Readiness Index" dari Responden (skala 1 – 5):

1. Optimisme : 3.96875
2. Inovasi : 4.09375
3. Ketidaknyamanan : 2.84375
4. Ketidakamanan : 3.21875

### Hasil dokumentasi Pengujian Tahap 2:

#### 1. TENTANG TAMPILAN WEB E-Marketplace dcreatifunika.id

##### Pendapat dan Masukan

- Sudah oke
- harus lebih dirapikan lagi layoutnya
- Kalau bisa dikasih tema untuk tampilan. deskripsi ditambahkan. ditambahkan beberapa berat. ditambahkan banner page,
- logo Dcreative Unika kurang menarik, etalase kurang menarik
- untuk alamat web nya saya memiliki saran untuk merapihkan lagi alamat webnya lalu ada link yang masih "404 not found" ketika di tekan seperti contohnya gambar "Dcreative Unika" ketika di tekan keluar pesan 404 Not Found dan mungkin ada yang lain lagi tetapi masi belum terlihat
- untuk fitur yang tersedia masih banyak permasalahan seperti descripsi yang terbatas, lalu pemasukan foto yang hanya bisa 1 gambar, dan juga pemberian harga. Untuk masukannya perbanyak fitur fitur yang meyakinkan konsumen contohnya: menginputkan video deskripsi produk
- tampilan produk-produk yang bawaan dari template masih muncul di halaman pertama, dan ada harga yang dicoret seakan akan diskon padahal harganya sama saja.
- lebih diperbaiki lagi saat daftar toko supaya tidak sampai terjadi kegagalan daftar karena merugikan diri sendiri.
- saat pengisian data toko, kalo bisa untuk mempermudah, dikasih seperti pencarian, misal "" saat mengisi alamat kota kalo di ketik saja SEMARANG, maka sdh keluar dan bisa di tekan / pencet"

#### 2. Tentang Desain Web E-Marketplace dcreatifunika.id yang responsive

##### Pendapat dan Masukan

- Sudah bagus, rapi, dan menarik
- kurang cepat.
- web sudah cukup responsif
- Layout kontennya masih kurang di deskripsi belum bisa di beri deskripsi panjang dan di bagian weight atau berat masih belum di kasi 0. atau desimalnya
- untuk design yang ditampilkan sudah cukup baik
- desain sudah oke, di bagian stok harian kurang di "enter", masih menyatu dengan line sebelumnya

### **3. Tentang Fungsionalitas Website E-Marketplace dcreatifunika.id**

#### **Pendapat dan Masukan**

- Saat mendaftarkan toko, pada bagian konfirmasi pass (lebih baik diberi notif/kode jika pass sudah sama)
- Sudah bagus, namun harus lebih disempurnakan lagi
- ditambahkan logo toko
- saat memasukkan produk, data produk masih terbatas
- untuk fungsionalitas website sepertinya sudah lancar dan bisa di akses semua
- log in dan register lainnya sudah cukup bagus
- walaupun sudah sign up, harus login lagi

### **4. Tentang Navigasi dalam Web E-Marketplace dcreatifunika.id**

#### **Pendapat dan Masukan**

- Sudah berfungsi dengan baik dan harus lebih dikembangkan lagi
- lebih cepat
- navigasi toko kurang lengkap
- navigasi web dcreatif sudah lancar
- untuk navigasinya alangkah baiknya menambahkan lokasi set yang menampilkan maps, agar lebih mudah mendapatkan alamat yang jelas
- ketika klik logo DCreative, masih belum ada isinya.

### **5. Tentang Performa Web E-Marketplace dcreatifunika.id**

#### **Pendapat dan Masukan**

- Harus diperbaiki lagi, karena jika saya memasukkan deskripsi terlalu panjang uploadnya agak lama
- agak lama kalau bisa lebih cepat
- kecepatan upload sudah cukup baik
- untuk kecepatan upload dan tayang konten sudah lancar
- untuk uploadnya masih ada eror
- kecepatan upload sudah oke, cukup cepat dan tidak terlalu berat saat load
- Sudah cepat

### **6. Lain-lain**

#### **Pendapat dan Masukan**

- Harus diperbaiki lagi di saat memasukkan tulisan disaat daftar toko, karena jika terlalu panjang ataupun ada titik akan muncul error
- "Ditambahkan logo toko
- ditambahkan pengiriman mau pake via apa"

- jika memungkinkan gunakan jasa hosting dan server yang lebih baik, atau lebih baik lagi memiliki server sendiri
- buat website nya menjadi semakin rapih
- Kolom untuk memasukkan deskripsi produk hanya 1 baris, sulit untuk mengedit dan melihat, tidak bisa diberi "enter", berat produk tidak bisa desimal, sebaiknya diubah menjadi gram saja agar lebih fleksibel.
- Dipertahankan, kalo perlu di update / perbaiki menurut dari masukan orang yang mencoba menggunakan nya

### III. Hasil Pengujian III WEB E-Marketplace dcreatifunika.id 26 Nov 2020

#### Daftar Peserta Pengujian:

No	Nama	Email	Status	Usia	Gender
1	Evangeline Eunike	19n40001@student.unika.ac.id	Mahasiswa	19	Wanita
2	Edward Galang Wibowo	19n40002@student.unika.ac.id	Mahasiswa	19	Pria
3	Te Boo Boo	tebooboo05@gmail.com	Mahasiswa	19	Wanita
4	Yehuda Joy Muljanto	19n40003@student.unika.ac.id	Mahasiswa	19	Pria
5	Emmanuel Evan	19n40005@student.unika.ac.id	Mahasiswa	19	Pria
6	Kenny Gavriel Susanto	19n40006@student.unika.ac.id	Mahasiswa	19	Pria
7	Maria Kineta	19n40012@student.unika.ac.id	Mahasiswa	> 21	Wanita
8	Michael Hans Christian P	19n40008@student.unika.ac.id	Mahasiswa	> 22	Pria
9	Benedikta Avien Ardyani	benedictvn.69@gmail.com	Mahasiswa	18	Wanita
10	Ong Vincent Indra P	20n10016@student.unika.ac.id	Mahasiswa	18	Pria
11	Gouw, Owen Andrew setiawan	20n10024@student.unika.ac.id	Mahasiswa	18	Pria
12	David Marcelijo Vico S	20n40006@student.unika.ac.id	Mahasiswa	18	Pria
13	Benedictus Brian Renaldi Darmawan	17n10020@student.unika.ac.id	Mahasiswa	21	Pria
14	TEOFILUS GAGAH VESTIANNADA	20n10032@student.unika.ac.id	Mahasiswa	19	Pria
15	Axell Victoryan Nugroho	20n40005@student.unika.ac.id	Mahasiswa	18	Pria
16	Ng Suvandi Prasetio	20n10001@student.unika.ac.id	Mahasiswa	18	Pria
17	Albertus Prido Nathanael	20n10021@student.unika.ac.id	Mahasiswa	18	Pria
18	Raymond Christian Valentino	20n10011@student.unika.ac.id	Mahasiswa	17	Pria
19	Laurensius Aldo	20n40001@student.unika.ac.id	Mahasiswa	18	Pria
20	alvin christian sutanto	20n10028@student.unika.ac.id	Mahasiswa	18	Pria
21	Albertus Christ Dwi Kurniawan	20n10004@student.unika.ac.id	Mahasiswa	18	Pria
22	Evan Prasetyo	20n10009@student.unika.ac.id	Mahasiswa	18	Pria
23	Qosda Muhdi Umar Umaya	20n10033@student.unika.ac.id	Mahasiswa	18	Pria
24	Nicholas Dwiki Tanoto	20n10007@student.unika.ac.id	Mahasiswa	18	Pria
25	Syifa khofifah	20n10020@student.unika.ac.id	Mahasiswa	18	Wanita
26	Fernando Setiawan	fernandosetiawan7@gmail.com	Mahasiswa	17	Pria
27	Vania Renata	20n20005@student.unika.ac.id	Mahasiswa	19	Wanita
28	C Oktoriananda L.N.	20n40011@student.unika.ac.id	Mahasiswa	18	Wanita
29	Lisna Noviati	20n10018@student.unika.ac.id	Mahasiswa	18	Wanita
30	Daniel Eka Pratama Sanjaya	20n10008@student.unika.ac.id	Mahasiswa	18	Pria
31	Hierro Megantara	17n10022@student.unika.ac.id	Mahasiswa	21	Pria
32	Michael Samuel keuain	20n10025@student.unika.ac.id	Mahasiswa	18	Pria
33	Jason Brilly	-	Mahasiswa	18	Pria
34	David Kresna Husodo	-	Mahasiswa	17	Pria
35	Benedicta Nathania Nugroho	20.N1.0023	Mahasiswa	18	Wanita

No	Nama	Email	Status	Usia	Gender
36	Scolastika Merryana Christa Dini	20.N1.0031	Mahasiswa	19	Wanita
37	Marcelino Febrian Handana	20n10030@student.unika.ac.id	Mahasiswa	19	Pria
38	Stanislaus michael s	20n40002@student.unika.ac.id	Mahasiswa	18	Pria
39	Natasha Diva Muljono	20n10012@student.unika.ac.id	Mahasiswa	18	Wanita
40	William Ong Listijono	20n10006@student.unika.ac.id	Mahasiswa	18	Pria
41	Edward Winata Sugianto Putra	20.N2.0001	Mahasiswa	17	Pria
42	Michael Anthony N	20n4004@student.unika.ac.id	Mahasiswa	18	Pria
43	Titus Theo Yoga Baskara	20.N1.0019	Mahasiswa	19	Pria
44	awaludin latif faizin	20n40013@student.unika.ac.id	Mahasiswa	20	Pria
45	Ernest	20n10017@student.unika.ac.id	Mahasiswa	17	Pria
46	Christian Kurnia Wardhana	20n40007@gmail.com	Mahasiswa	18	Pria
47	Bellarmino Bintang Pradipta	20.N1.0015	Mahasiswa	18	Pria
48	Abednego Wijaya Adiwibowo	20n10014@student.unika.ac.id	Mahasiswa	18	Pria
49	Natalia Diva Muljono	20n10013@student.unika.ac.id	Mahasiswa	18	Wanita
50	Dionisius Luky Pratama	19.N1.0021	Mahasiswa	19	Pria
51	Immanuel Agus Erlangga	im.erlanggtr@gmail.com	Mahasiswa	20	Pria
52	Chatarina Yekti Prawihatmi	yekti@unika.ac.id	Pakar UMKM	> 21	Wanita

Link rekaman pelaksanaan pengujian:

<https://drive.google.com/drive/folders/1AFFdE85fwRt9cjdPCgS7xfSlihjo83V>

Pengukuran "Technology Readiness Index" dari Responden (skala 1 – 5):

1. Optimisme : 4.068181818
2. Inovasi : 3.781960227
3. Ketidaknyamanan : 2.982954545
4. Ketidakamanan : 3.448863636

Hasil dokumentasi Pengujian Tahap 2:

#### 1. TENTANG TAMPILAN WEB E-Marketplace dcreatifunika.id

##### Pendapat dan Masukan

- dibuat lebih rapi
- tampilannya bagus, sangat kreatif, dan simple
- tampilan web dcreatif di buat lebih menarik
- dibuat lebih elegan
- Tampilan web sudah rapi dan enak untuk dilihat. Menarik
- Tampilan untuk harga produk di buat lebih sesuai
- Tampilan tambahkan sistem cod
- ditambah interface yg berguna
- Tampilan sudah enak di pandang
- Tampilan web sudah menarik, layout yang digunakan sudah tepat
- tampilan web nya sudah baik dan mudah dimengerti

- Tampilan menarik dan enak dipandang
- tampilannya kurang berwarna
- Tampilan Sudah Bagus seperti marketplace lainya
- masih perlu dikembangkan
- tampilan web mudah dipahami dan user friendly.
- Tampilan home nya sepi dan kurang segar
- Tampilannya baik dan mudah dimengerti
- tampilan web terlalu monoton dan kurang enak dipandang
- Sudah cukup membantu

## **2. Tentang Desain Web E-Marketplace dcreatifunika.id yang responsive**

### **Pendapat dan Masukan**

- responsif
- Sudah bagus untuk dilihat
- bagus sekali
- Banyak yang belum bisa diclick saat di home
- Desainnya sudah terlihat menarik dan bagus.
- telalu polos untuk warna
- Desain Web sudah bervariasi dan lengkap
- konten yang ditampilkan lebih baik yang direkomendasikan/sering dicari/diskon
- desain sudah bagus
- desain responsivenya perlu diperbaiki
- desain web kurang menarik
- Menarik
- semua layout sudah bagus
- Desainnya menarik
- Performa meningkat
- Desain nya simple dan bagus
- desain web nya agak rumit
- design web membosankan dan kurang menarik
- desain modern
- membingungkan
- Layout web sudah baik dan lebih jelas
- tingkat responsif web kurang.
- masih kurang menarik
- desain nya web sudah responsive dan tidak lemot
- Sudah oke dan berfungsi baik
- Desain webnya sudah bagus
- desain web sudah lengkap dan baik
- Sangat kreatif

## **3. Tentang Fungsionalitas Website E-Marketplace dcreatifunika.id**

### **Pendapat dan Masukan**

- berfungsi dgn baik
- Fungsi login perlu di perbaiki
- berjalan dengan lancar

- mudah
- Masih bug karena beberapa kali memasukan name adress email
- Untuk penggunaan pembayaran masih error
- checkout, tidak ada pemberitahuan jika barang yang sudah habis.
- untuk login sudah baik
- cart kurang responsive
- sistem log in harus di benahi
- saat stok sudah habis mohon barang kalo bisa otomatis dihilangkan
- fungsionalitas sudah baik
- Bagus
- add to cart langsung masuk ke full view produknya, kurang nyaman saat scrolling di website
- Pengisiannya ribet
- Sudah muncul berbagai macam fungsi
- login oke
- kurang lengkap untuk cara pembayarannya
- konfirmasi pembelian seharusnya otomatis saat kita sing in
- shipping chart belum sempurna
- kurang sempurna
- sudah sangat bagus
- ada beberapa akses yang masih error
- fungsional website berfungsi baik saat login,dan register
- alamat di menu ada agar setiap transaksi tidak perlu memasukkan alamat terus menerus
- sudah baik untuk fungsionalitas web nya
- Fitur sign up dan sign in bagus dan cepat
- saat memilih provinsi seharusnya pilihan kota itu cuman ada di provinsi yang kita pilih
- password, diberi fitur untuk melihat pasword yang di ketik.
- Log in dan register tolong di percepat responya
- kadang masih error
- Semua menu sudah bagus dan berfungsi dengan baik
- untuk login, sign up, service cart, dll sudah bekerja dengan baik.
- Fungsionalitasnya sudah berjalan dengan baik dan tidak ada kendala.
- login masih suka error, masih banyak yang belum diisi konten
- Mudah di akses

#### **4. Tentang Navigasi dalam Web E-Marketplace dcreatifunika.id**

##### **Pendapat dan Masukan**

- sesuai kategori
- bagus dan tepat
- Masih banyak yang belum bisa diakses
- navigasi nya cukup menarik
- Navigasi lokasi saat kita memilih provinsi, kota dalam di provinsi tersebut.
- navigasi sudah baik
- sudah memberikan petunjuk yang jelas bagi pengguna, sehingga mudah digunakan
- pengarahannya sudah baik
- tidak ada tata cara penggunaan web tersebut untuk orang yang tidak paham menggunakannya
- navigasi kurang bagus

- Adanya your cart is empty
- Sudah bagus sih menurut saya
- kurang lengkap panduannya
- masih ada beberapa tombol navigasi yang masih belum bisa diaktifkan
- navigasinya dibuat lebih simple
- kurang begitu jelas untuk tulisan
- navigasi sudah cukup jelas dan mudah untuk digunakan
- bisa berfungsi dan berjalan dengan sangat baik.
- navigasi lengkap
- Pengarahannya sudah lumayan jelas
- Navigasi sudah baik dan jelas tombol-tombolnya
- fitur pencarian masih error dan keluar sql
- navigasi sudah bagus dan tambahi kategorinya supaya lebih menarik
- masih membingungkan
- untuk navigasi web sudah tepat sesuai dengan keinginan pembeli
- Sangat bagus dan sangat mudah dimengerti dengan panduan yang jelas
- cukup mudah dipahami, mungkin tulisannya dibesarkan sedikit supaya mudah dilihat
- navigasinya sudah cukup jelas tidak ada kendala.
- Mudah diakses untuk orang awam teknologi

## **5. Tentang Performa Web E-Marketplace dcreatifunika.id**

### **Pendapat dan Masukan**

- cepat dan responsif
- Agak lambat
- Sudah cukup bagus
- lumayan cepat
- Kurang responsive dan masih banyak bug serta kurang dalam tampilan
- performa lumayan
- Kecepatan performa dari web dcreatif sudah cukup responsif dan baik.
- kecepatan upload barang sudah cepat, namun terkadang ada bug sql mohon di perbaiki
- Kecepatan performa sudah cukup cepat
- kecepatan upload sudah baik
- performa web sudah bagus
- sudah baik
- performa web bagus dan tidak lemot
- Sangat Cepat
- Terlalu banyak buffering dan lama
- Sudah meningkat dari sebelumnya
- Cepet kok, gak down servernya.
- Untuk kecepatan uploadnya sudah bagus.
- biasa saja, karena aplikasi ini masih baru jadi saya maklumi
- sangat bagus
- performa sudah cukup baik
- Sudah lumayan tidak lenot dibanding yang kemarin
- kecepatan upload sudah baik.
- performa web sudah baik



- sangat cepat dan tidak lemot sama sekali
- Web responsif dan tidak ada kendala saat mengakses web
- sudah bagus dan cepat buat upload
- kadang mengalami lag
- performa web sudah baik
- untuk kecepatan baik dalam pembayaran atau halaman sudah baik
- Masalah loading mungkin menurut saya masih agak lama
- cukup mudah dan cepat
- tidak ada masalah soal kecepatan upload dan tayang konten
- Kecepatan dalam checkout produk dan mengakses produk cepat, tidak ada kendala.
- masih sedikit lemot waktu pas mau upload dan penayangan konten-kontennya
- Sangat cepat responnya

## 6. Lain-lain

### Pendapat dan Masukan

- checkout bila barangnya habis harus menunjukkan notifikasi barang habis.
- Semua sudah cukup bagus, kedepannya ditingkatkan lagi
- sudah bagus
- Saat register, lebih baik ada konfirmasi yang dikirim melalui email.
- pemilihan kota ada kota yang termuat, untuk pembelian tidak perlu mengisi ulang data diri
- Pilihan produk diperbanyak
- hanya kota yang di provinsi tersebut yg ditampilkan
- overall sudah bagus
- tingkatkan keamanan
- Pembayaran M-banking Tidak Ada, memilih provinsi, pilihan kota itu hanya ada di provinsi itu.
- untuk kategori bisa di tambah lagi
- UI nya kurang rapi dan agak bingung ini buat apa
- mengklik keranjang utk beli, sehingga masih bisa langsung belanja kembali
- semoga bisa cepat aktif beroperasi webnya.
- sudah sangat bagus, cuma untuk pemilihan warna agar tulisan jelas
- desain layout sudah baik namun kurang mencolok (terlalu sederhana)
- tambahkan fitur m-banking, cod
- tambahkan variasi barang yang dijual
- Jika barang habis ada pemberitahuan barang habis
- memasukan alamat pada saat register tidak bisa menulis alamat lengkap/ panjang
- barang nya lebih banyak agar lebih banyak pilihan dalam berbelanja dan lebih banyak promo
- bingung banyak hal yang kurang dimengerti saat mengisi malah error dan keluar sql
- ditambahkan fitur pembayaran m bank, dan cod. pada fitur checkout mungkin masi ribet harus mengisi alamat dll lagi, seharusnya tdk perlu karna sudah mengisi di register.
- Tambahkan fitur COD, Tambahkan fitur M-Banking
- sudah lumayan
- masih perlu perbaikan
- tampilan web dibuat lebih rame
- ditambahi kategori " Jasa" tersendiri misalnya make up artist, grooming, cuci sepatu
- fitur search belum bisa digunakan
- setiap toko diberikan logonya dan logo dari webnya

- tambahkan untuk pembayaran kredit

## **Lampiran:**

### **Kuisisioner Pengukuran Technology Readiness Level**

#### **Optimisme:**

1. Saya menyukai teknologi E-marketplace yang memungkinkan saya untuk menyesuaikan berbagai hal agar sesuai dengan kebutuhan saya sendiri
2. Saya suka ide berbisnis online via E-marketplace karena tidak terbatas pada jam kerja biasa
3. Teknologi E-marketplace membuat saya lebih efisien dalam pekerjaan bisnis saya
4. Teknologi E-marketplace menyediakan lebih banyak kebebasan untuk hidup dan bekerja sesuai saya

#### **Inovasi**

1. Belajar tentang teknologi E-marketplace bisa sama bermanfaatnya dengan teknologi itu sendiri
2. Saya mengikuti perkembangan teknologi E-marketplace terbaru di bidang minat saya
3. Saya lebih suka menggunakan teknologi E-marketplace paling canggih yang tersedia
4. Saya memiliki lebih sedikit masalah dibandingkan orang lain dalam menggunakan teknologi E-marketplace

#### **Ketidaknyamanan**

1. Sangat memalukan jika saya mengalami masalah dengan teknologi tinggi E-marketplace saat orang lain melihatnya
2. Sepertinya teman-teman saya belajar lebih banyak tentang teknologi E-marketplace terbaru daripada saya
3. Di lingkaran pertemanan saya, orang lebih dikagumi jika mereka menggunakan E-marketplace terbaru
4. Saya tidak menganggap aman berbisnis online via E-marketplace

#### **Ketidakamanan**

1. Saya kurang percaya diri berbisnis dengan tempat yang hanya bisa dijangkau secara online (E-marketplace)
2. Saya khawatir informasi yang saya sediakan di E-marketplace dapat disalahgunakan oleh orang lain
3. Setiap kali sesuatu menjadi otomatis (E-marketplace), saya perlu memeriksa dengan cermat bahwa sistem tidak membuat kesalahan
4. Setiap transaksi bisnis yang saya lakukan secara elektronik di E-marketplace harus dikonfirmasi nanti dengan komunikasi terpisah

# 1. Pengujian ke-1 (Pengujian E-Marketplace dcreatifunika.id dari sisi pelapak/penjual)

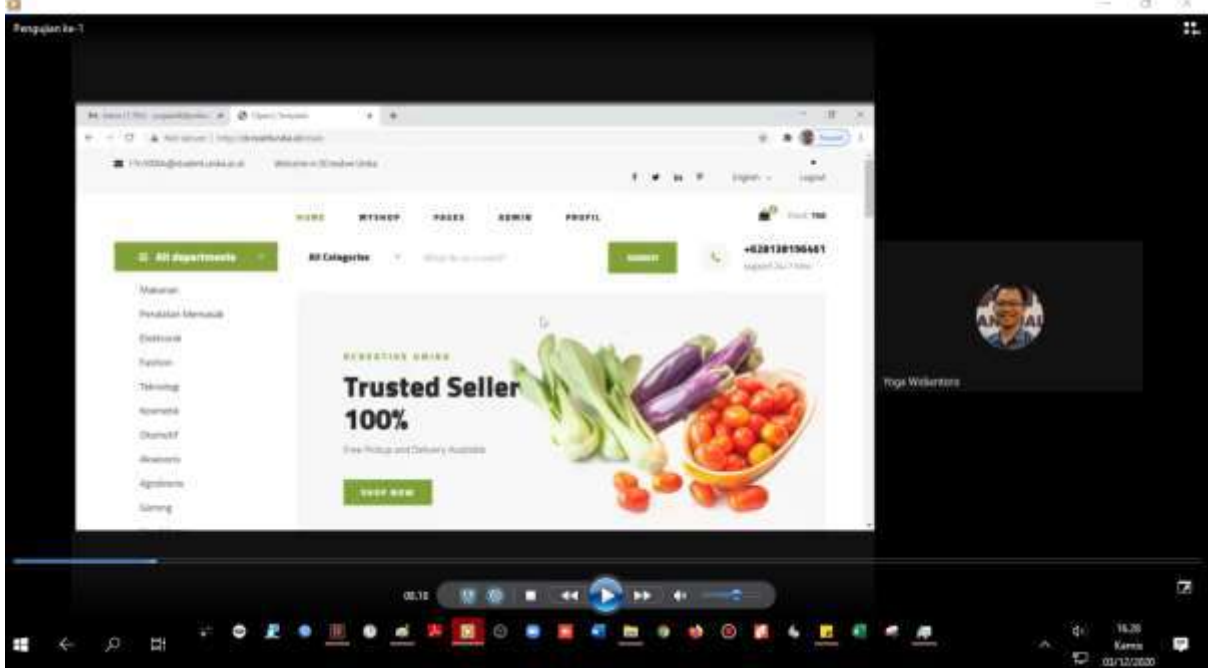

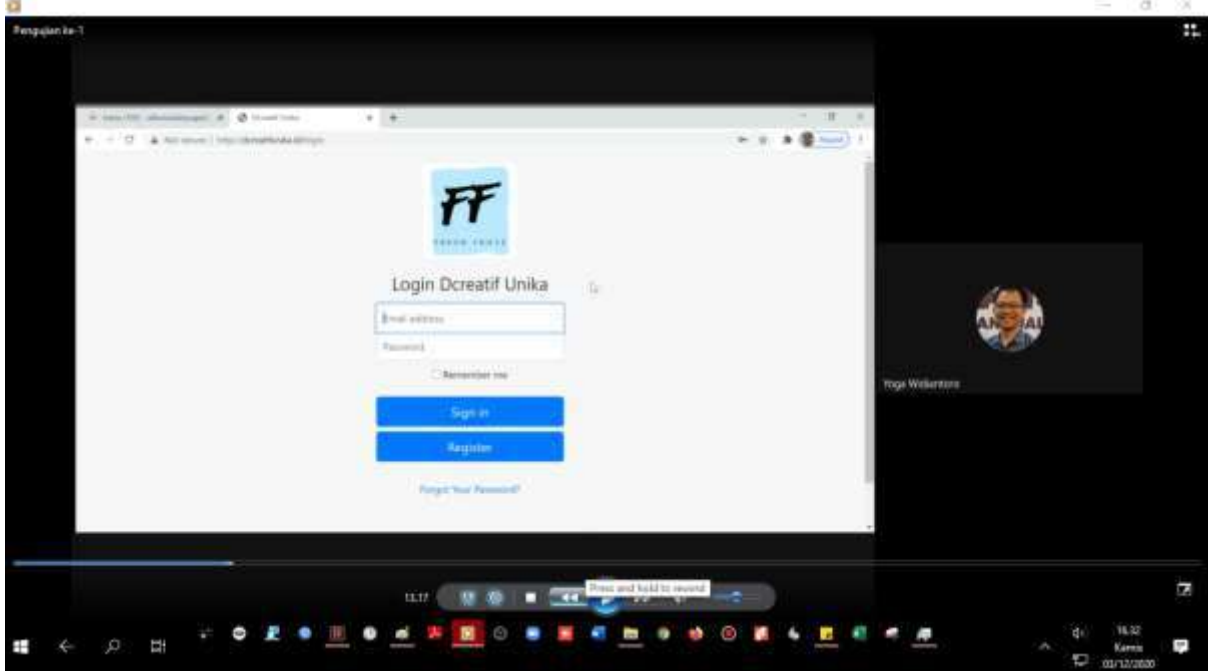
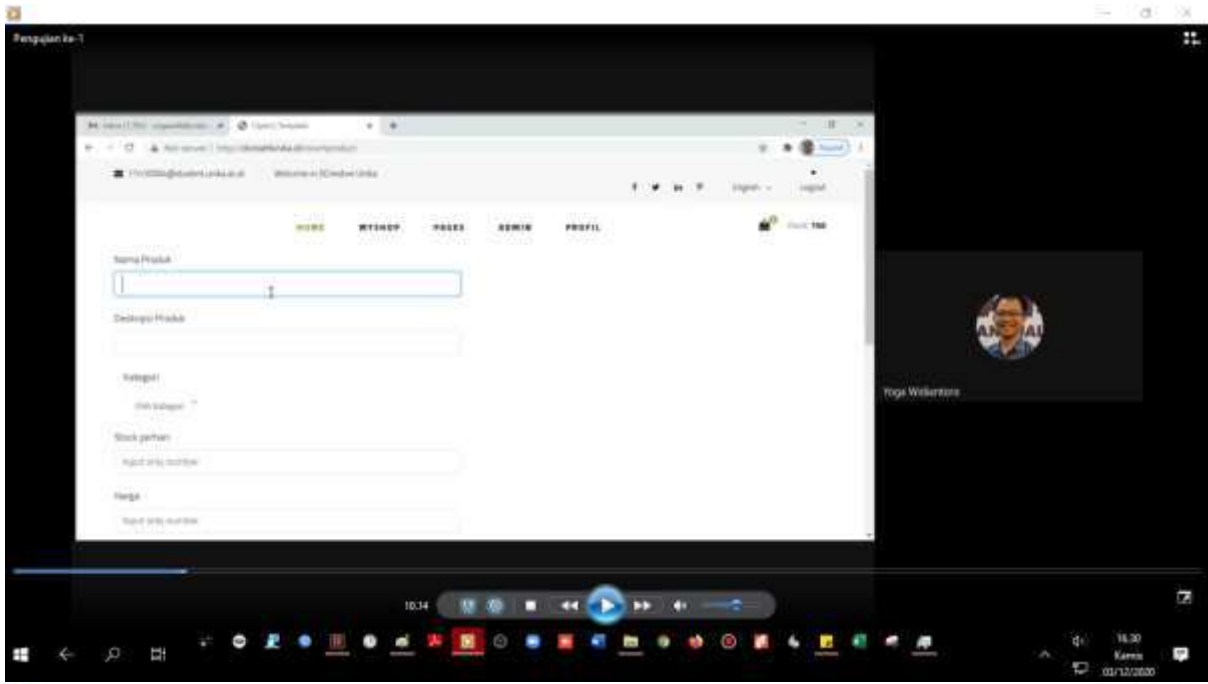

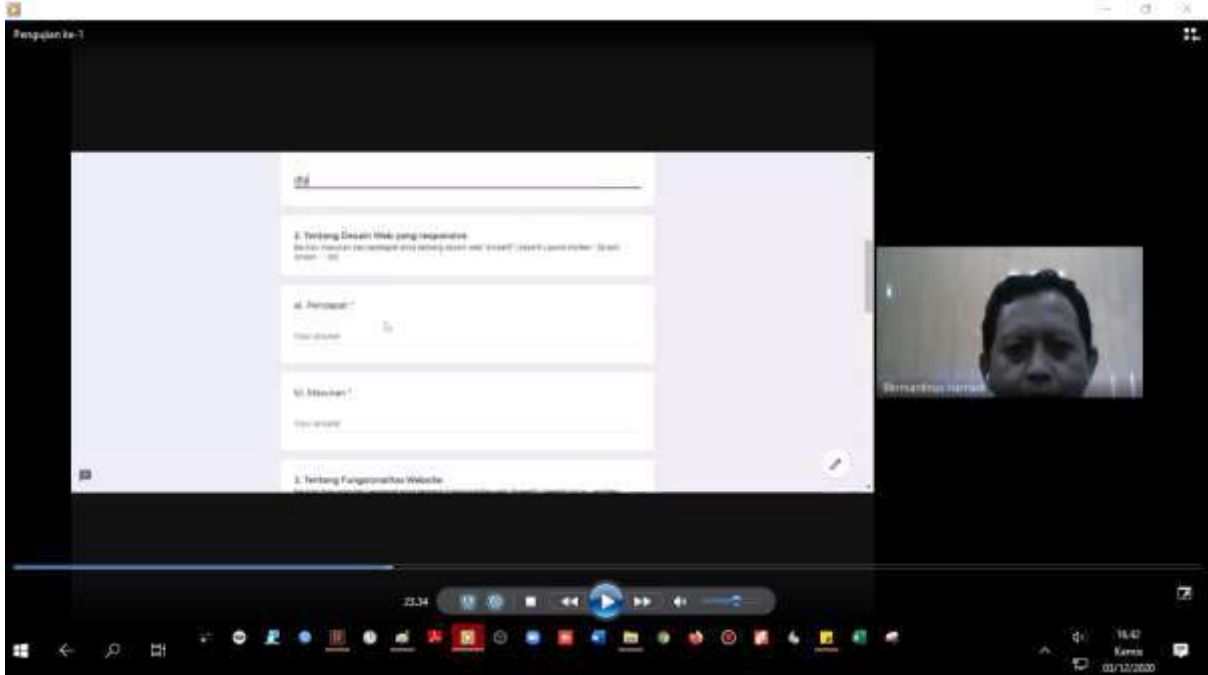
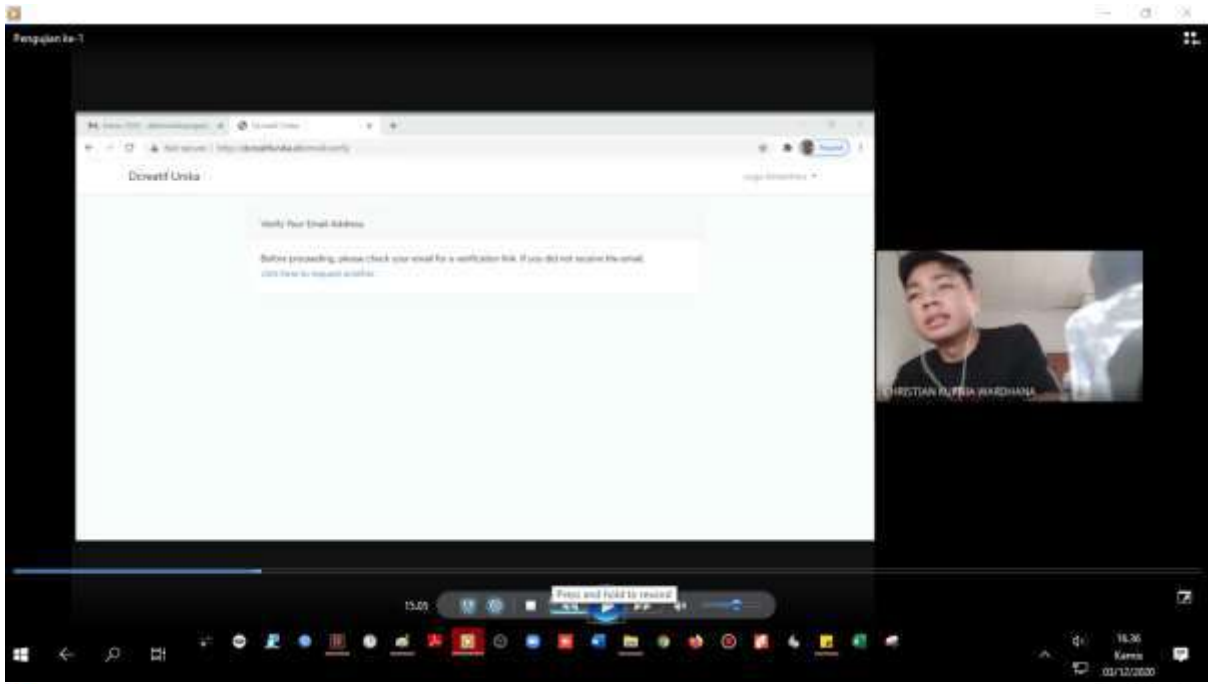

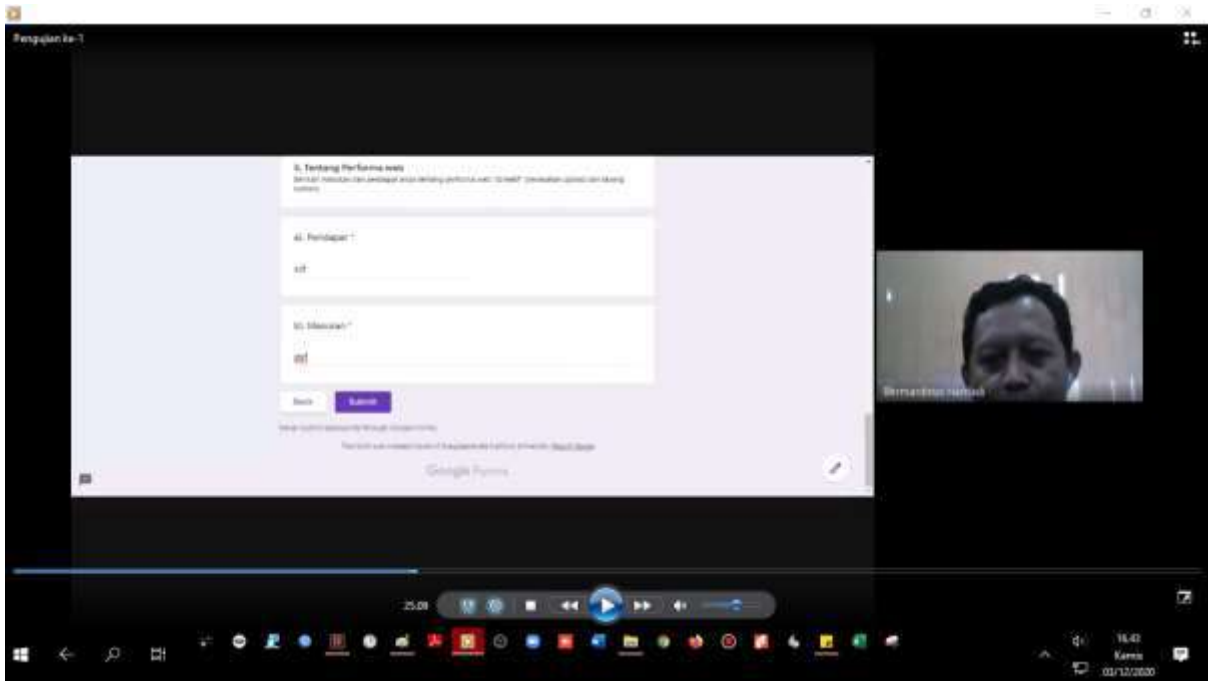

## 2. Pengujian ke-2 (Pengujian E-Marketplace dcreatifunika.id dari sisi pelapak/penjual)

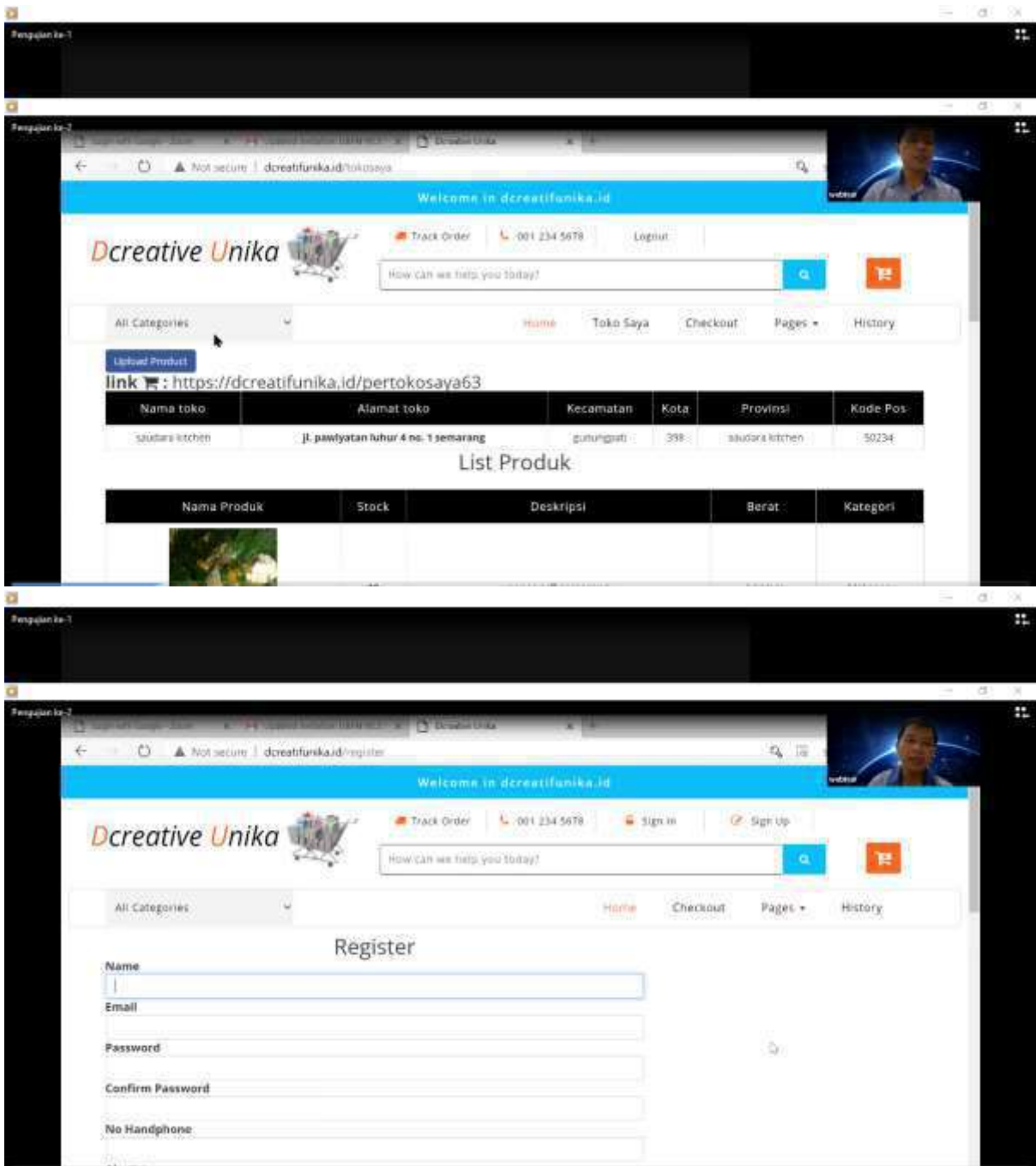



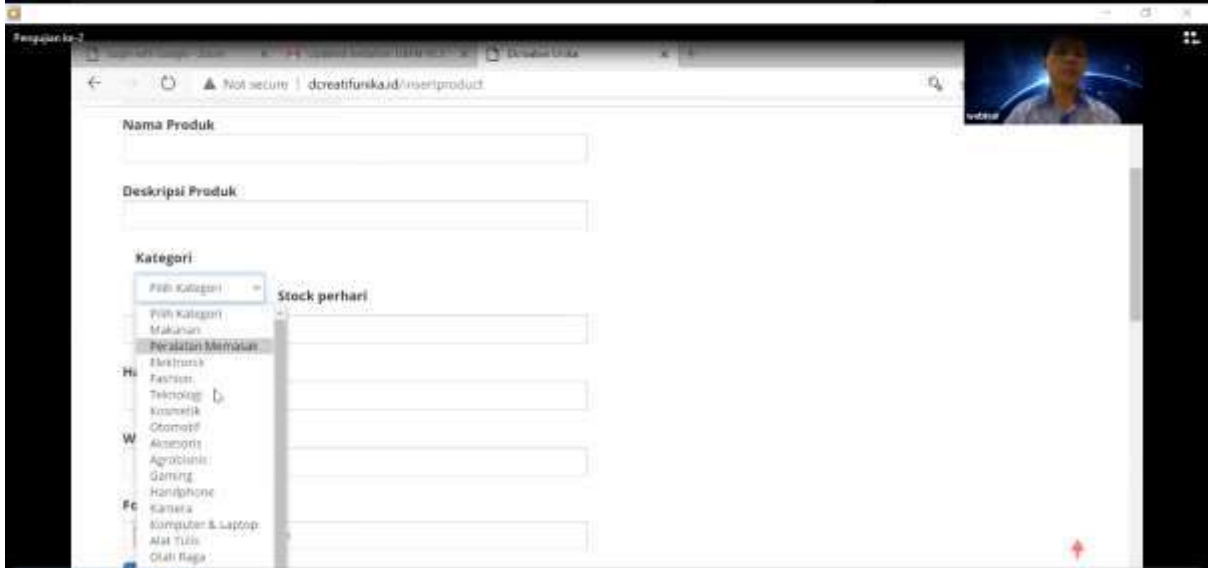
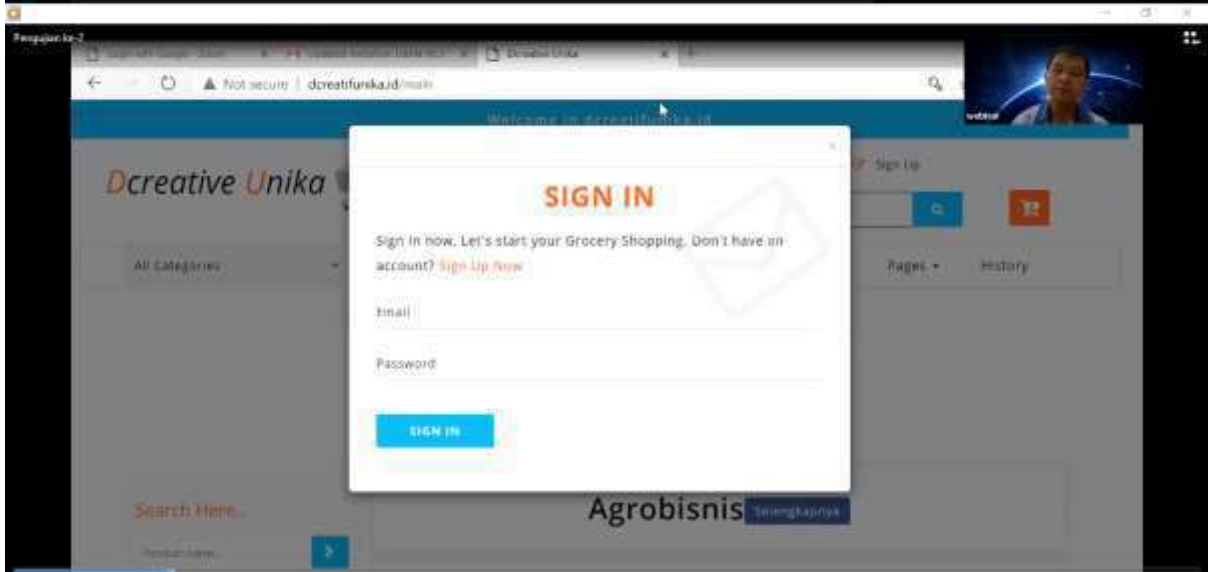

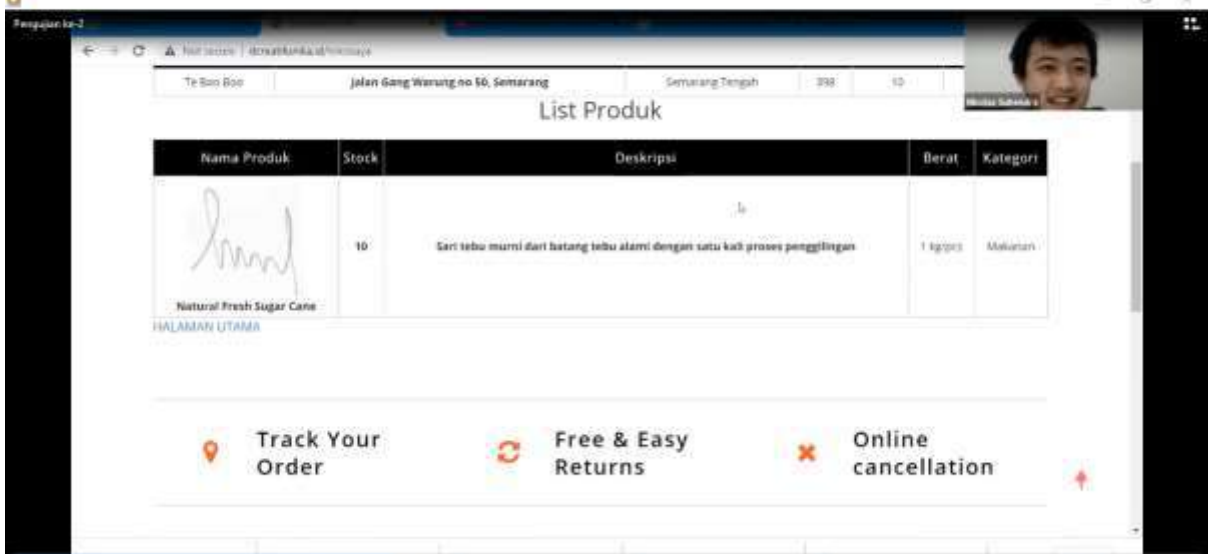
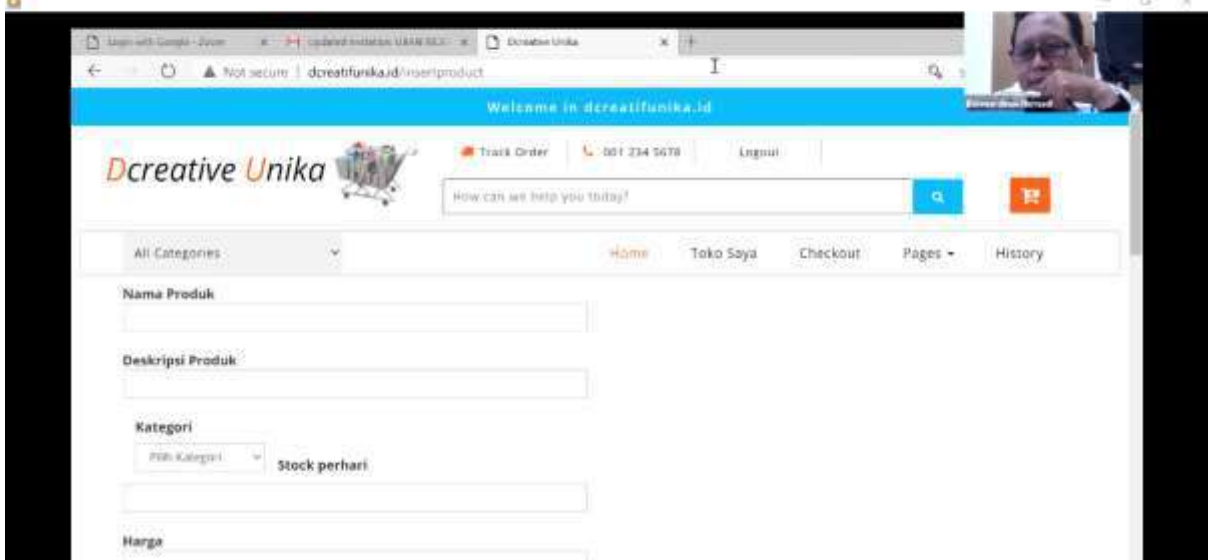



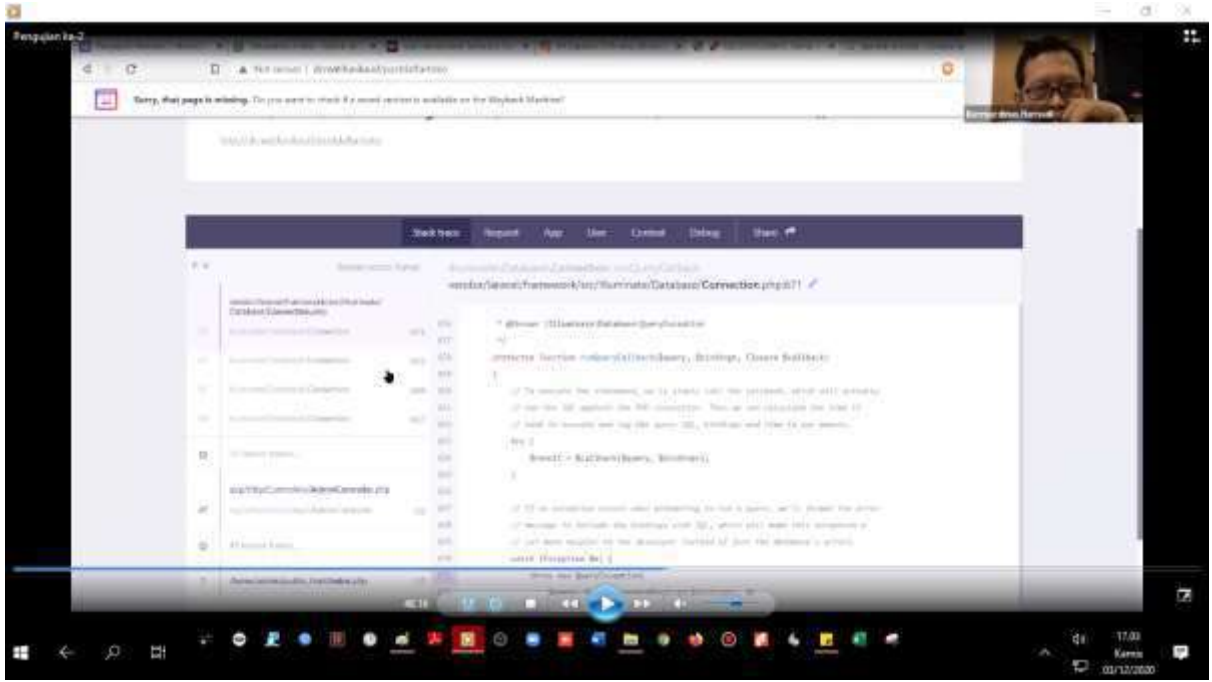

### 3. Pengujian ke-3 (Pengujian E-Marketplace dcreatifunika.id dari sisi pembeli)

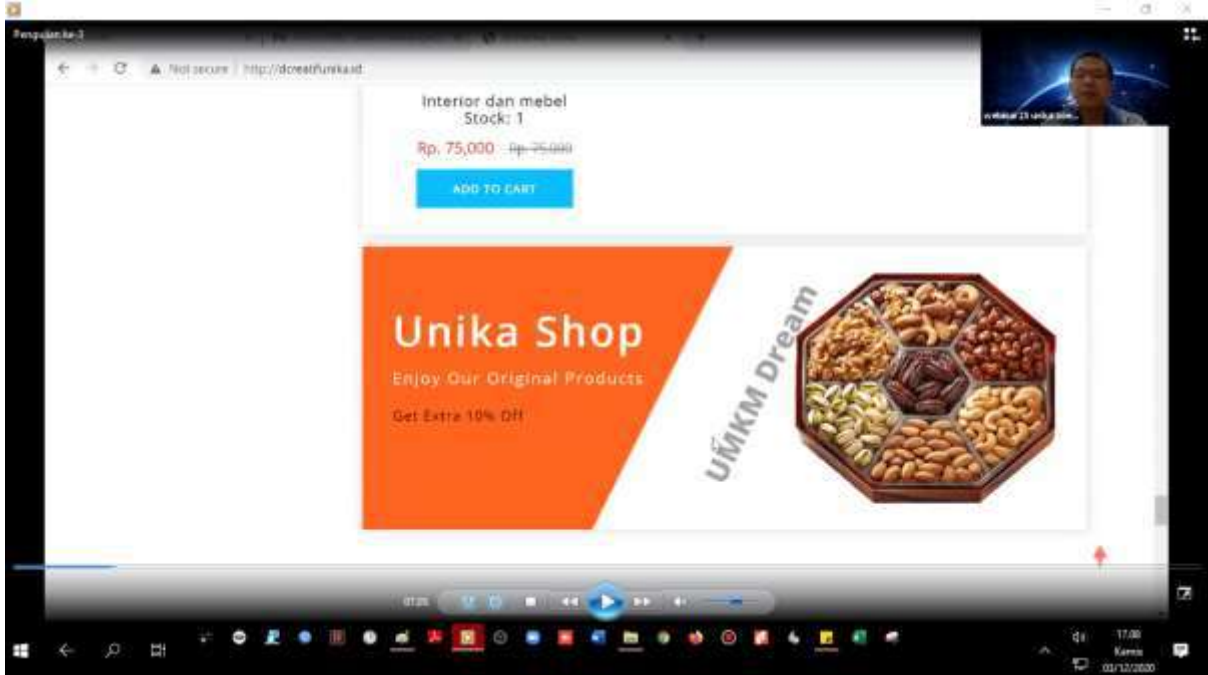
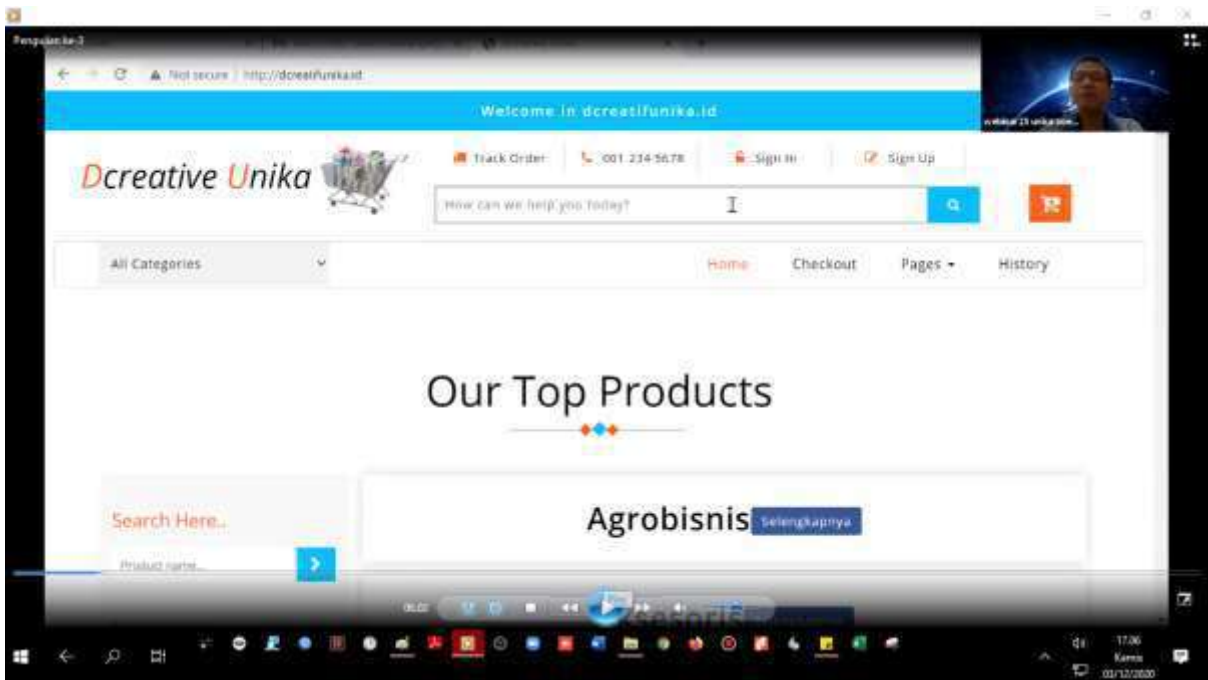

**Kaos hitam polos**  
 ★★★★★  
 Rp. 75,000 **Free delivery**  
 Cash on Delivery Eligible  
 Shipping Speed to Delivery  
 Sold and fulfilled by Supple Tek (3.6 out of 5 | 6 ratings)  
 1 offer from Rp. 75,000

This is a **Fashion** product.

- Baju kaos polos warna hitam (ukuran + S)
- After cooking, Zeeta Basmati rice grains attain an extra ordinary length of upto 2.4 cm/1 inch.
- Zeeta Basmati rice adheres to the highest food safety standards as your health is paramount to us.
- Confirms only the best and purest grade of basmati rice grain of Export quality.

All food products are **non-returnable**.

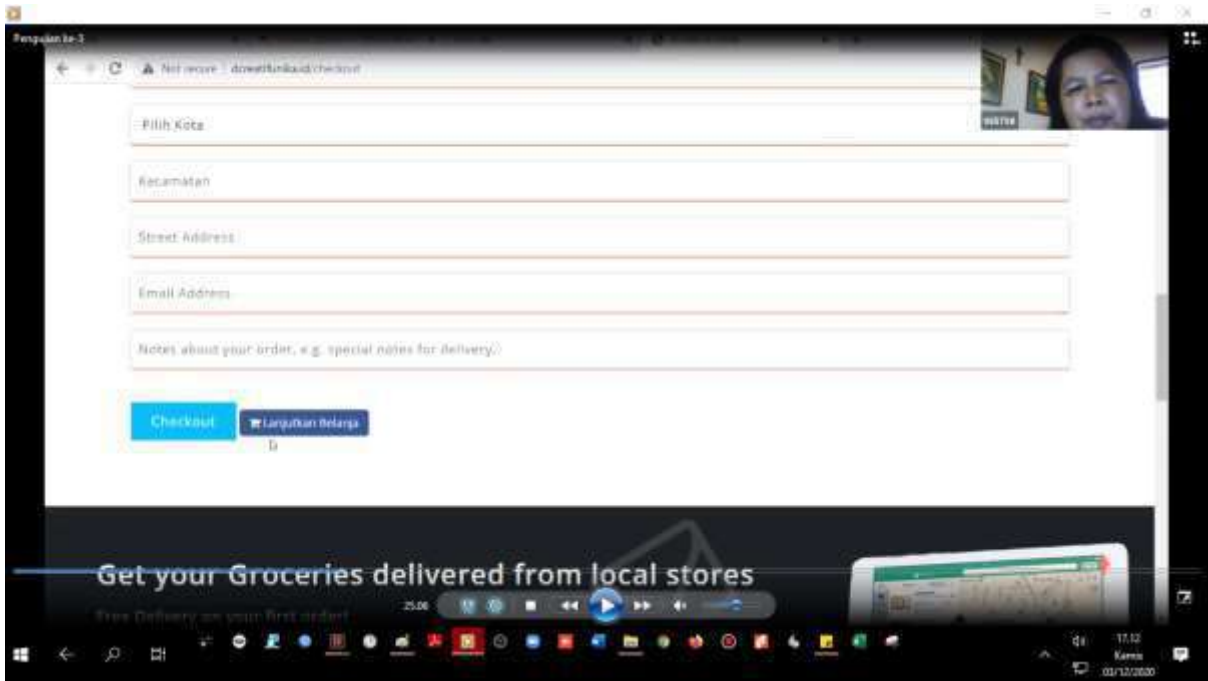

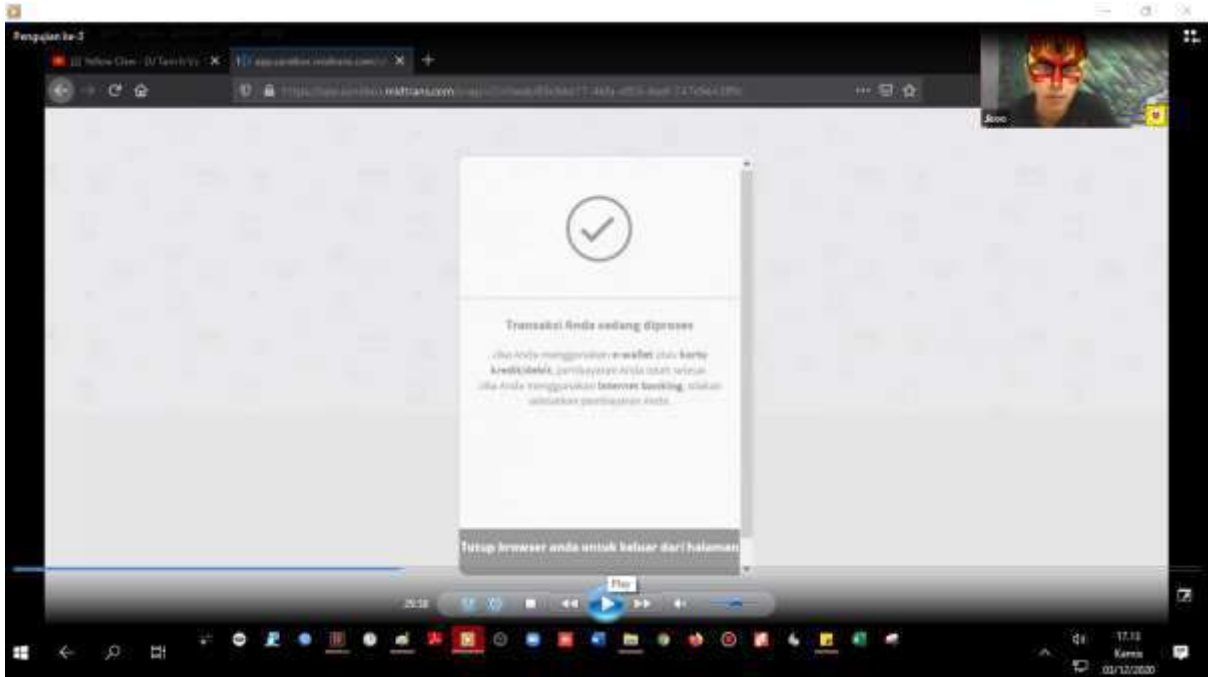
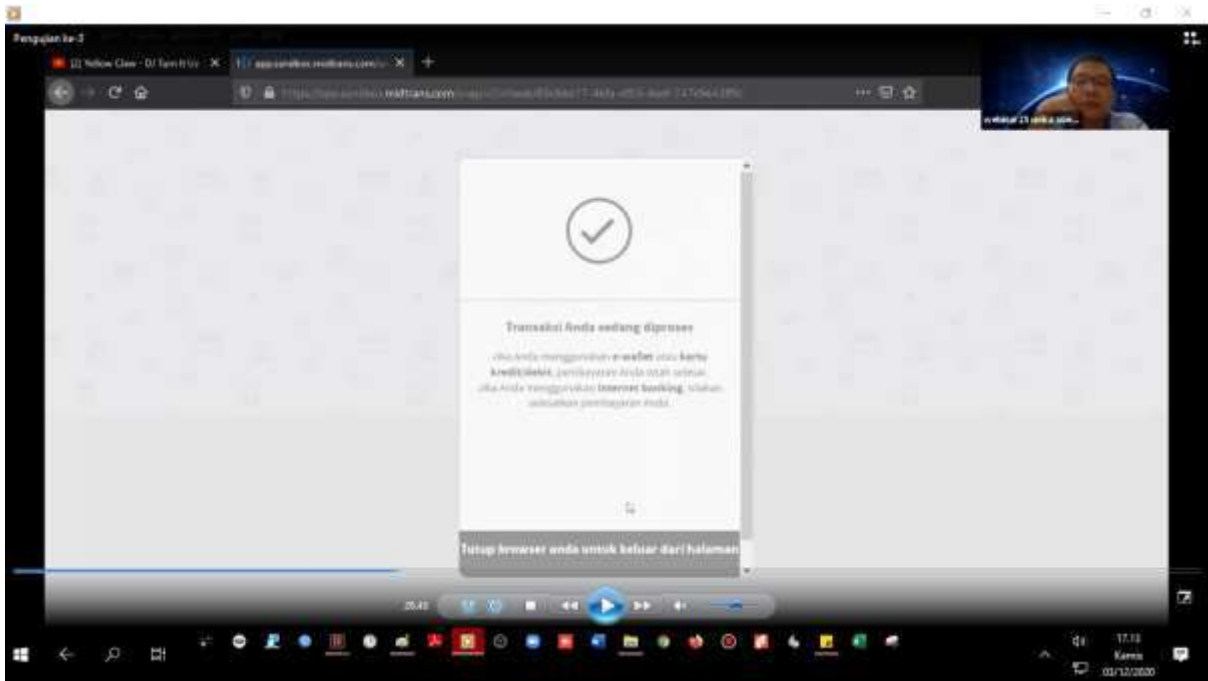



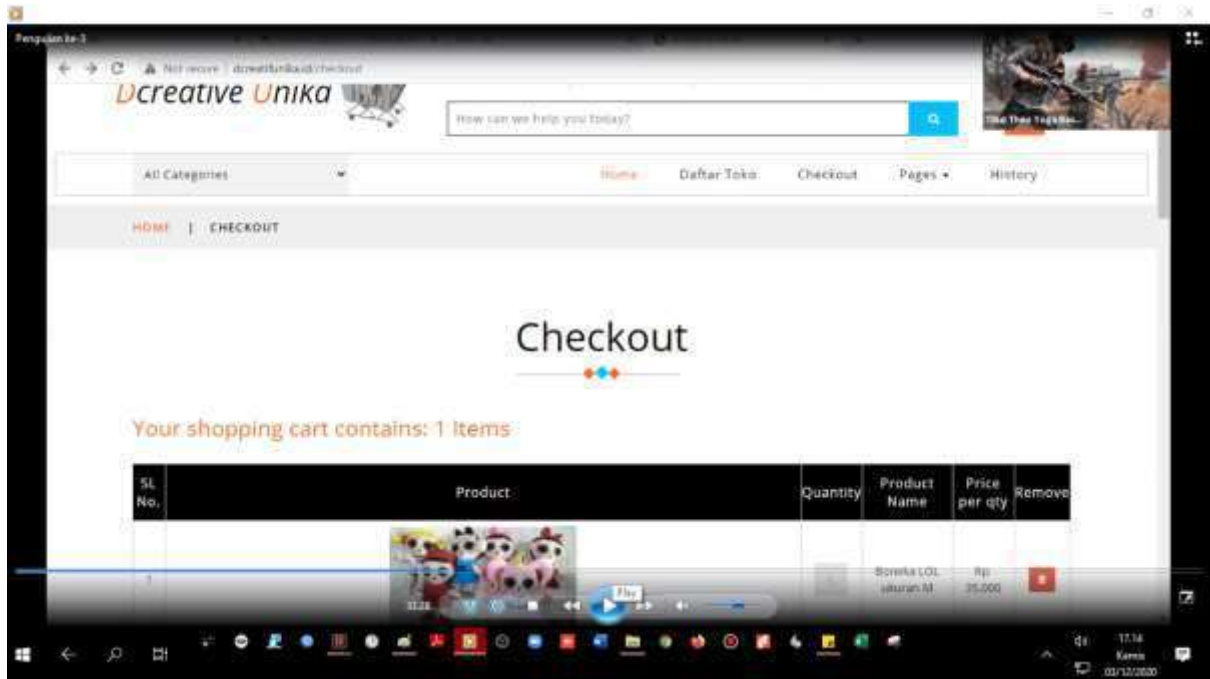

Dokumen pendukung luaran Tambahan #1

Luaran dijanjikan: Prosiding dalam pertemuan ilmiah Internasional

Target: sudah terbit/sudah dilaksanakan

Dicapai: Accepted

Dokumen wajib diunggah:

1. Naskah artikel
2. Surat keterangan accepted dari editor

Dokumen sudah diunggah:

1. Naskah artikel
2. Surat keterangan accepted dari editor

Dokumen belum diunggah:

-

Peran penulis: co-author

Nama Konferensi/Seminar: The 5th International Conference on Informatics and Computing (ICIC2020)

Lembaga penyelenggara: Aptikom

Tempat penyelenggara: Kota Gorontalo, Sulawesi Indonesia

Tgl penyelenggaraan mulai: 3 November 2020 | Tgl selesai: 4 Desember 2020

Lembaga pengindeks: IEEE Xplore

URL website: <https://icic-aptikom.org/>

Judul artikel: Investigating the Impact of System and Service Qualities on Customer Loyalty in Acceptance of EMarketplace

ICIC  
2020



# Certificate of Participation

*This is to certify that*

**FX Hendra Prasetya , Bernardinus Harnadi, Albertus Dwiyoga  
Widiantoro, Achmad Nizar Hidayanto, Agus Cahyo Nugroho**

has written the Paper titled

**Investigating the Impact of System and Service Qualities on Customer  
Loyalty in Acceptance of E-Marketplace**

*at the 5th International Conference on Informatics and Computing (ICIC2020)  
held between 3-4 November 2020  
at Virtual Conference of ICIC 2020*

General Chair of APTIKOM,

Zainal A. Hasibuan



Organising Chair of ICIC 2020

Yusuf Durachman



Sponsors :



Co-Host :



# Investigating the Impact of System and Service Qualities on Customer Loyalty in Acceptance of E-Marketplace

FX Hendra Prasetya  
Department Information System  
Faculty Computer Science  
Soegijapranata Catholic University  
Semarang, Indonesia  
email: hendra@unika.ac.id

Achmad Nizar Hidayanto.  
Faculty Computer Science  
University of Indonesia  
Depok, Indonesia 16424  
email: nizar@cs.ui.ac.id

Bernardinus Harnadi  
Department Information System  
Faculty Computer Science  
Soegijapranata Catholic University  
Semarang, Indonesia  
email: b\_harnadi@unika.ac.id

Agus Cahyo Nugroho  
Department Information System  
Faculty Computer Science  
Soegijapranata Catholic University  
Semarang, Indonesia  
email: agus.nugroho@unika.ac.id

Albertus Dwiyooga Widianoro.  
Department Information System  
Faculty Computer Science  
Soegijapranata Catholic University  
Semarang, Indonesia  
email: yoga@unika.ac.id

**Abstract**—This paper aims to investigate the influence of System and Service Quality on Customer Loyalty in their acceptance of e-marketplaces. The e-marketplaces are Tokopedia, Bukalapak, Lazada, Sopheo, and others. Several variables from previous related studies on expectation–confirmation model (ECM) and TAM are employed on proposed model to explore the customers satisfaction and their impact on the acceptance of the e-marketplace. The model expresses the effect of System Quality, Service Quality on Confirmation and Satisfaction; Confirmation on Perceived Usefulness and Perceived Ease of Use; Perceived ease of use on Perceived Usefulness; Perceived Usefulness, and Confirmation on Satisfaction; and Perceived Usefulness and Satisfaction on Continuance Intension to use. The model was examined using 210 respondent data and Correlation Analysis was done after the validity and reliability check to reveal the correlation of variables. The analysis of causal effects of variables are tested using Structural Equation Modelling (SEM) using Partial Least Square (PLS). The result reveals that the Satisfaction of customer of e-marketplace platforms were more affected by System Quality, Service Quality and Confirmation than Perceived Usefulness. Whereas, the continue intention to use e-marketplace platform was determined by Perceived Usefulness and Satisfaction. The results have contribution on e-marketplace players and developers who have concern on customer loyalty to attract their continue intention in using the platform.

**Keywords**—adoption, e-marketplace, system quality, service quality, satisfaction

## I. INTRODUCTION

The digital era is moving very fast, especially driven during the Covid-19 pandemic where people are advised to live or work at home, to be used to do all digital-based activities carried out at home. It provides opportunities and challenges. The scale of opportunity for businesses has changed, transactions and communication are no longer through traditional channels (physical encounters) but through e-commerce technology.

In today's dynamic movement, it presents opportunities and challenges for decision makers. Increased opportunities for digital businesses have increased, this increase has reached

up to 10 or even 20 times that of traditional channels. Even individuals can expand markets from all over the world. Digital marketing provides powerful tools for creating audience engagement, identifying customers, increasing sales, and increasing efficiency and productivity in a variety of areas. To win the competition, companies must position themselves at the forefront of technology, be innovative in making attractive products, consider price and place, and use digital-based commercial platforms [1].

E-commerce platforms allow customers to sort and categorize information and even access opinions from online customer reviews and ratings to improve the shopping process and increase the number of choices available. On the other hand, decreased customer satisfaction can result mainly due to lack of security, relevant privacy, timely human contact [2].

Evidently, the Internet has produced fundamental changes in retail practices, created shifts in both consumer and business behavior, the positive relationship between e-customer satisfaction and consumer shopping at e-commerce retailers has been proven. Namely, the higher the e-customer satisfaction in this area, the more consumers are [3].

System quality is the user's perception of stability, acceptable response, and ease of use. It has been shown that an increase in perceived system quality is related to an increase in perceived usefulness, as well as an increase in user satisfaction with the system. Higher perceived system quality has a stronger effect on perceived usefulness and user satisfaction, leading to a positive influence on system adoption [4].

E-commerce today is part of the community because it can meet people's expectations. E-commerce has become one of the alternative shopping in addition to shopping in conventional marketplaces. The development of e-commerce is the result of the increasingly widespread role of technology use today. Meeting the expectations of performance aspects makes e-commerce like a "primadonna", an inclusive and unlimited digital era is one of the primary elements that make e-commerce warmly welcomed throughout the world. The thing that underlies fast-moving e-commerce in the modern world is because of the assumption that e-commerce is more comfortable and more practical (perceived usefulness) in its

use and has been proven to be able to meet effort expectancy [5-9].

In this research, the original ECM was modified with the addition of 2 components, namely System Quality and Service Quality to adopt the use of e-marketplaces. And this is the contribution proposed in this study.

## II. RELATED WORK

Theoretical base – expectation–confirmation model (ECM) and investment model (IM) Past research has applied different technology usage models to explore users’ continuance intention, such as UTAUT2 [10], TAM [11,12] and ECM [13]. Although these studies provide insights into understanding users’ continuance usage of fitness and health apps, by primarily applying a single model and including limited factors, previous studies could only provide an insufficient explanation of individuals’ postadoption behavior. On the other hand, to explore what contributes to a sustained relationship, the IM that was initially developed to understand interpersonal relationship has been applied in the technology context [14,15,16,17,18]. The IM addresses the limitation of the ECM, which primarily focuses on users’ perceptions toward the IT product/service [19]. However, the IM theory has not yet been used to investigate the user–app relationship. Therefore, this study integrates the ECM and IM to address the utilitarian and commitment perspectives of individuals’ usage of fitness and health apps [20].

Research conducted by Aslam et al [21] examines the ECM model used for mobile social commerce. This study used the expectation confirmation model (ECM) in developing the model related to continuance usage intention of mobile social commerce. For testing the relationships, structural equation modeling (SEM) is used by using Amos 22. The findings of the study will help the brands in understanding key determinants that help in building brand loyalty in the mobile social commerce context and will expand the literature of mobile social commerce in the context of developing economies. The study provides numerous implications for brand managers in boosting brand loyalty. The paper is organized as follows; section 2 represents the theoretical background and literature. Section 3 emphasizes the development of hypotheses. Details related to the methodology are presented in section 4. Section 5 presents the results. Lastly, section 6 presents conclusion, recommendation and future area to research.

**Expectation-Confirmation Model** The expectation-confirmation model is a framework used by researchers to explain and understand matters relating to consumer satisfaction, trust and sustainability in purchasing or using a service [22,23]. Besides, some researchers explained that ECM is adopted to explain acceptance, use or adoption of a technology [24,25,26]. ECM shows that consumer behavior in purchasing based on their own decisions, on the other hand, consumers will rely on their expectations of how well the services they receive. In addition, the information received by consumers with regard to the product or service will greatly affect the decision in purchasing; of course the information is expected to be accurate and reliable [27]. Meaning of expectation refers to how far the level of user satisfaction in feeling something, based on his experience using technology. Meanwhile, perceived usefulness is a feeling experienced by users to measure how far a person is believing the use of technology whether it is useful or not. Satisfaction is a positive

emotional state resulting from the evaluation of the use of the technology, and continuance intention is useful as a reference to measure how far the customers intend to repurchase the technology or continue the use of the service [28]. If their expectations are met based on the use of such information technology, then the customers are likely to be satisfied and assume the technology is useful. In turn, customers tend to use technology continuously [28,29].

The adoption of e-commerce for generation Z has been researched by Lestari [30], in this study the variables used are Personal innovativeness, Self efficacy, Perceived usefulness, Perceived risk, Attitude, Intention.

In this study, we will use ECM development by adding a quality and service quality system to adopt the use of e-marketplaces.

## III. PROPOSED MODEL AND HYPOTHESIS

By using existing literature on research in the last six years regarding the adoption of e-commerce, mobile apps, and technology adoption, the model offered in this study is compiled as shown in Figure 1.

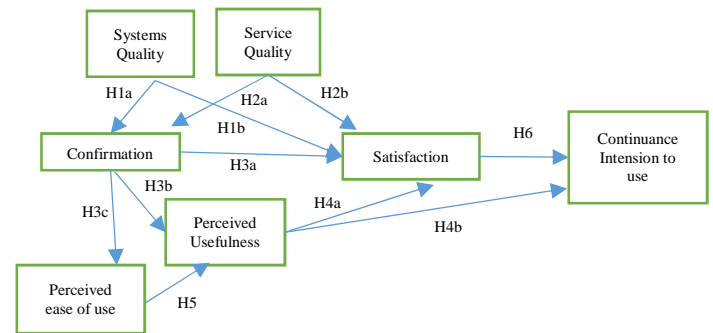

Fig. 1. Proposed model

### A. System Quality, service Quality, Perceived Usefulness, and Confirmation on Satisfaction (H2b, H1b, H3a, H4a)

In Park's research [31] between system and service quality has a positive correlation to satisfaction. This is reinforced by research by Daghan, G and Akkoyunlu, B [32] that between System Quality and Service Quality has a positive correlation to Satisfaction, so that the H1b and H2b hypotheses can be made. Likewise, confirmation and Perceived Usefulness have a positive relationship with satisfaction [31,32,33,28], so hypotheses H3a and H4a can be made.

**H1b: Systems Quality has a positive effect on Satisfaction**

**H2b: Service Quality has a positive effect on Satisfaction**

**H3a: Confirmation has a positive effect on Satisfaction**

**H4a: Perceived Usefulness has a positive effect on Satisfaction**

### B. System Quality and service Quality on Confirmation (H1a, H2a)

Gokhan [32] and Park [31] extended ECM with System and Service quality, based on this hypothesis H1a and H1b are made.

**H1a: Systems Quality has a positive effect on Confirmation**

**H2a: Service Quality has a positive effect on Confirmation**



It can be seen that the value of each indicator loading outer value is greater than 0.7.

To see the Average Variance Extracted (AVE) value can be seen in table 3.

TABLE III. NILAI AVERAGE VARIANCE EXTRACTED (AVE)

Variable	Average Variance Extracted (AVE)
CI	0.815
Con	0.725
PEoU	0.748
PU	0.641
SQ	0.626
SV	0.692
Sat	0.811

Based on Table 3, all variables have an AVE value above 0.5. From Table 2 and Table 3, it can be seen that this model meets the requirements for convergent validity.

### 2. Discriminant Validity

For the discriminant validity test, the Fornell-Lacker criterion was used, the results of this test can be seen in table 4.

TABLE IV. FORNELL-LARCKER CRITERION VALUES

	CI	Con	PEoU	PU	SQ	SV	Sat
CI	0.903						
Con	0.501	0.852					
PEoU	0.596	0.598	0.865				
PU	0.622	0.663	0.664	0.801			
SQ	0.53	0.702	0.63	0.652	0.791		
SV	0.575	0.768	0.637	0.663	0.706	0.832	
Sat	0.545	0.694	0.683	0.622	0.692	0.712	0.901

Based on the values listed in Table 4, each variable has the greatest value by itself compared to other variables. Therefore, this model qualifies for discriminant validity.

### 3. Reliability Test

Reliability refers to the consistency or stability of an indicator. Reliability is measured by the value of composite reliability and Cronbach's alpha. Table 5 will display the composite reliability and cronbach's alpha values of each construct.

TABLE V. THE VALUE OF COMPOSITE RELIABILITY AND CRONBACH'S ALPHA

	Cronbach's Alpha	Composite Reliability
CI	0.886	0.929
Con	0.811	0.888
PEoU	0.887	0.922
PU	0.719	0.841
SQ	0.797	0.869
SV	0.777	0.871

Sat	0.883	0.928
-----	-------	-------

According to Table 5, it can be seen that all constructs have a composite reliability value above 0.7, which means that the variable is reliable.

### C. Structural Model Test

After doing the measurement model and this model has passed the measurement model test, the next step is to do the structural model test. The structural model test is to analyze the structural relationship between the measured variables and their latent variables. The structural model test includes path coefficients and coefficient of determination test.

#### 1. Test the path coefficients

The basis for determining whether a hypothesis is accepted or not using path coefficients. The results can be seen in table 6.

TABLE VI. VALUE OF PATH COEFFICIENTS

	CI	Con	PEoU	PU	SQ	SV	Sat
CI							
Con			0.598	0.413			0.197
PEoU				0.418			
PU	0.462						0.027
SQ		0.317					0.205
SV		0.544					0.221
Sat	0.258						

From table 6 it can be seen that the value less than 0.1 is from PE to Sat, which means that the PE variable is not correlated with the Sat variable.

#### 2. Coefficient of Determination

Testing the coefficient of determination or R<sup>2</sup> aims to find out how accurate the prediction of the model made in this study is. The coefficient of determination explains how much the ability of the independent variable to explain the variance of the latent variable. The results of the interpretation of the coefficient of determination can be classified into 3 levels, namely small, medium or large effect size. Table 7 shows the coefficient of determination of the three factors used in the research model.

TABLE VII. R SQUARE AND R SQUARE ADJUSTED VALUES

	R Square	R Square Adjusted
CI	0.428	0.422
Con	0.641	0.637
PEoU	0.357	0.354
PU	0.551	0.547
Sat	0.642	0.633

All determination values are above 0.26 or 26% which means large effect size (strong)

### 3. Hypothesis testing

Hypothesis testing was carried out using a two-tailed test by comparing p-values with a significance level of 5%. The results of hypothesis testing using SmartPLS will produce mean, standard deviation, t-statistics, and p-values. Hypothesis testing is conducted to check the structural validity of the model and determine which hypotheses are accepted and rejected from the comparison of p-values and significance levels. If the p-value is below 5%, the hypothesis will be accepted and if the p-value is above 5%, the hypothesis will be rejected.

TABLE VIII. HYPOTHESIS TEST RESULTS

	Sample Mean (M)	Standard Deviation (STDEV)	T Statistics ((O/STDEV))	P Values	Hypothesis
Con -> PEoU	0.595	0.064	9.342	0	Accepted
Con -> PU	0.414	0.054	7.618	0	Accepted
Con -> Sat	0.194	0.083	2.39	0.017	Accepted
PEoU -> PU	0.417	0.055	7.59	0	Accepted
PU -> CI	0.463	0.066	7.031	0	Accepted
PU -> Sat	0.03	0.066	0.411	0.681	Rejected
SQ -> Con	0.315	0.066	4.814	0	Accepted
SQ -> Sat	0.2	0.076	2.711	0.007	Accepted
SV -> Con	0.546	0.064	8.474	0	Accepted
SV -> Sat	0.226	0.087	2.548	0.011	Accepted
Sat -> CI	0.258	0.072	3.59	0	Accepted

From table 8, it can be seen that all the hypotheses are support, except for H4a not support because the P value is above 5% or 0.05. The following is a picture of the model after testing the hypothesis.



Fig. 2. The final model after testing. \*p < 0.05, \*\*p < 0.01, \*\*\*p = 0

The findings in this study are that the largest users of e-marketplaces are people aged between 20-29 years with a diploma and undergraduate education level, namely 60% of 210 respondents.

Based on Figure 2, it can be seen that almost all of the hypotheses made in this study are accepted except for hypothesis 4a, namely Perceived Usefulness has an effect on user satisfaction. This is because most e-marketplace users are not satisfied with the benefits of shopping online, they still like to shop offline, they can see firsthand the items they are going

to buy and they can also try or taste these items. This is in line with the research of Aslam et al, Prasetya and Harnadi [21,34] who also have the same result, namely Perceived Usefulness does not affect Satisfaction.

In Hypotheses 1a and 1b, namely the effect of the Quality System on Confirmation and Satisfaction, this is true or acceptable because e-marketplaces that have a good quality system will have an effect on confirmation from the user and will also lead to a feeling of satisfaction for the user. This is in line with research conducted by the 2017 gokhan [32]

Hypotheses 2a and 2b, namely the effect of Service Quality on Confirmation and Satisfaction, have been proven from the results of statistical tests, this proves that an e-marketplace that has good service will make its customers feel that it is what they expect and also make them satisfied. If customers feel satisfied, then they will usually become loyal customers.

If customers feel satisfied with the quality system and good service quality from the e-marketplace, then this will make customers loyal and will continue to use the e-marketplace.

From this research, it is proven that the desire to continue using the e-marketplace platform is determined by Perceived Usefulness and Satisfaction. This result implies that e-marketplace players and developers who have a strong interest in loyalty to attract their interest in using the platform in a sustainable manner.

### REFERENCES

- [1] Lawrence, J.E., Tar, U.A., "Barriers to ecommerce in developing countries," Inform. Soc. Justice, vol. 3, no. 1, pp. 23–35, 2010
- [2] E. Brynjolfsson, Y. (Jeffrey) Hu, and M. S. Rahman, "Battle of the Retail Channels: How Product Selection and Geography Drive Cross-Channel Competition," Manage. Sci., vol. 55, no. 11, pp. 1755–1765, 2009, doi: 10.1287/mnsc.1090.1062.
- [3] T. M. Nisar and G. Prabhakar, "What factors determine e-satisfaction and consumer spending in e-commerce retailing?," J. Retail. Consum. Serv., vol. 39, no. July, pp. 135–144, 2017, doi: 10.1016/j.jretconser.2017.07.010.
- [4] R. Z. Kuo, "EMRS Adoption: Exploring the effects of information security management awareness and perceived service quality," Heal. Policy Technol., vol. 7, no. 4, pp. 365–373, 2018, doi: 10.1016/j.hlpt.2018.10.012.
- [5] Oh, J.-C., & Yoon, S.-J., "Predicting The Use of Online Information Services Based On A Modified UTAUT Model," Behaviour & Information Technology, vol.33, no. 7, pp. 716–729, 2014.
- [6] Ramayasa, I. P., "Evaluation Model of Success And Acceptance of e-Learning," Journal of Theoretical and Applied Information Technology, vol 82, no. 3, pp. 462, 2015.
- [7] Farzin, S., & Dahlan, H. M., "Proposing A Model To Predict Students' perception Towards Adopting An E-Assessment System," Journal of Theoretical & Applied Information Technology, vol. 90, no. 1, 2016.
- [8] Malik Bader Alazzam, A., Samad Hasan Basari, A. S. S., Ibrahim, Y. M., Ramli, M. R., & Naim, M. H., "Trust In Stored Data In Ehrrs Acceptance Of Medical Staff: Using UTAUT2," International Journal of Applied Engineering Research, vol. 11, no. 4, pp. 2737–2748, 2016.
- [9] D. M. Mansur, E. T. Sule, D. Kartini, Y. M. Oesman, A. H. P. K. Putra, and N. Chamidah, "Moderating of the role of technology theory to the existence of consumer behavior on e-commerce," J. Distrib. Sci., vol. 17, no. 7, pp. 15–25, 2019, doi: 10.15722/jds.17.07.201907.15.
- [10] Yuan, S., Ma, W., Kanthawala, S. and Peng, W., "Keep using my health apps: discover users' perception of health and fitness apps with the UTAUT2 model", Telemedicine and e-Health, Vol. 21 No. 9, pp. 735-741, 2015.
- [11] Beldad, A.D. and Hegner, S.M., "Expanding the technology acceptance model with the inclusion of trust, social influence, and health valuation



- to determine the predictors of German users' willingness to continue using a fitness app: a structural equation modeling approach", *International Journal of Human-Computer Interaction*, Vol. 34 No. 9, pp. 882-893, 2018.
- [12] Chen, M.-F. and Lin, N.-P., "Incorporation of health consciousness into the technology readiness and acceptance model to predict app download and usage intentions", *Internet Research*, Vol. 28 No. 2, pp. 351-373, 2018.
- [13] Cho, J., "The impact of post-adoption beliefs on the continued use of health apps", *International Journal of Medical Informatics*, Vol. 87, pp. 75-83, 2016.
- [14] Giovanis, A., "Consumer-brand relationships' development in the mobile internet market: evidence from an extended relationship commitment paradigm", *The Journal of Product and Brand Management*, Vol. 25 No. 6, pp. 568-585, 2016.
- [15] Giovanis, A. and Athanasopoulou, P., "Consumer-brand relationships and brand loyalty in technology-mediated services", *Journal of Retailing and Consumer Services*, Vol. 40, pp. 287-294, 2018.
- [16] Uysal, A., "Commitment to multiplayer online games: an investment model approach", *Computers in Human Behavior*, Vol. 61, pp. 357-363, 2016.
- [17] Odrowska, A.M. and Massar, K., "Predicting guild commitment in World of Warcraft with the investment model of commitment", *Computers in Human Behavior*, Vol. 34, pp. 235-240, 2014.
- [18] Lin, J.-S., Sung, Y. and Chen, K.-J., "Social television: examining the antecedents and consequences of connected TV viewing", *Computers in Human Behavior*, Vol. 58, pp. 171-178, 2016.
- [19] Jin, X.-L., Lee, M.K.O. and Cheung, C.M.K., "Predicting continuance in online communities: model development and empirical test AU -Jin, Xiao-Ling", *Behaviour and Information Technology*, Vol. 29 No. 4, pp. 383-394, 2010.
- [20] W. Chiu, H. Cho, and C. G. Chi, "Consumers' continuance intention to use fitness and health apps: an integration of the expectation-confirmation model and investment model," *Inf. Technol. People*, 2020, doi: 10.1108/ITP-09-2019-0463.
- [21] Aslam, W., Ham, M. and Farhat, K., "Building Brand Loyalty: An Application of Expectation Confirmation Model in Mobile Social Commerce," *Journal of Commerce and Social Sciences*, Vol. 13, no.4, pp. 806-825, 2019.
- [22] Fan, L., & Suh, Y. H., "Why do users switch to a disruptive technology? An empirical study based on expectation-disconfirmation theory," *Information & Management*, vol. 51, no. 2, pp. 240-248, 2014.
- [23] Kim, D. J., Ferrin, D. L., & Rao, H. R., "Trust and satisfaction, two stepping stones for successful e-commerce relationships: A longitudinal exploration," *Information systems research*, vol. 20, no. 2, pp. 237-257, 2009.
- [24] Bhattacharjee, A., & Premkumar, G., "Understanding changes in belief and attitude toward information technology usage: A theoretical model and longitudinal test," *MIS quarterly*, vol. 28, pp. 229-254, 2004.
- [25] Halilovic, S., & Cicic, M., "Antecedents of information systems user behaviour-extended expectation-confirmation model," *Behaviour & Information Technology*, vol. 32, no. 4, pp. 359-370, 2013.
- [26] Stone, R. W., & Baker-Eveleth, L., "Students' expectation, confirmation, and continuance intention to use electronic textbooks," *Computers in Human Behavior*, vol. 29, no. 3, pp. 984-990, 2013.
- [27] Wu, I. L., "The antecedents of customer satisfaction and its link to complaint intentions in online shopping: An integration of justice, technology, and trust," *International Journal of Information Management*, vol. 33, no. 1, pp. 166-176, 2013.
- [28] Bhattacharjee, A., "Understanding information systems continuance: an expectation-confirmation model," *MIS Quarterly*, vol. 25, pp. 351-370, 2001.
- [29] I. W. K. Wijaya, A. A. G. Rai, and T. Hariguna, "The impact of customer experience on customer behavior intention use in social media commerce, an extended expectation confirmation model: An empirical study," *Manag. Sci. Lett.*, vol. 9, no. 12, pp. 2009-2020, 2019, doi: 10.5267/j.msl.2019.7.005.
- [30] D. Lestari, "Measuring e-commerce adoption behaviour among gen-Z in Jakarta, Indonesia," *Econ. Anal. Policy*, vol. 64, pp. 103-115, 2019, doi: 10.1016/j.eap.2019.08.004.
- [31] E. Park, "User acceptance of smart wearable devices: An expectation-confirmation model approach," *Telemat. Informatics*, vol. 47, no. December 2019, 2020, doi: 10.1016/j.tele.2019.101318.
- [32] G. Dalhan and B. Akkoyunlu, "Modeling the continuance usage intention of online learning environments," *Comput. Human Behav.*, vol. 60, pp. 198-211, 2016, doi: 10.1016/j.chb.2016.02.066.
- [33] C. Tam, D. Santos, and T. Oliveira, "Exploring the influential factors of continuance intention to use mobile Apps: Extending the expectation confirmation model," *Inf. Syst. Front.*, vol. 22, no. 1, pp. 243-257, 2020, doi: 10.1007/s10796-018-9864-5.
- [34] F. X. H. Prasetya and B. Harnadi, "Investigation of Adoption of Smartphone Technology for Learning," *ICSEC 2019 - 23rd Int. Comput. Sci. Eng. Conf.*, pp. 251-254, 2019, doi: 10.1109/ICSEC47112.2019.8974802.



Bernardinus Harnadi &lt;bharnadi@unika.ac.id&gt;

**Fwd: icic2020 notification for paper 118**

2 messages

**Fx. Hendra Prasetya** <hendra@unika.ac.id>  
To: Bernardinus Harnadi <bharnadi@unika.ac.id>  
Cc: Yoga Widianoro <yoga@unika.ac.id>

Sat, Sep 19, 2020 at 5:58 PM

Pengumuman ICIC 2020

----- Forwarded message -----

From: **icic2020** <icic2020-0@easychair.org>  
Date: Sab, 19 Sep 2020 5.08 PM  
Subject: icic2020 notification for paper 118  
To: Fx Hendra Prasetya <hendra@unika.ac.id>

Dear Fx Hendra Prasetya

We are pleased to inform you that your paper:

Paper ID: 118

Title: Investigating the Impact of System and Service Qualities on Customer Loyalty in Acceptance of E-Marketplace

that submitted to the 5th International Conference on Informatics and Computing (ICIC2020) has been ACCEPTED for an oral presentation. We cordially invite you to attend by presenting your paper in the ICIC2020.

It is mandatory to prepare the camera-ready paper as per the instructions listed on ICIC2020 website (<https://icic-aptikom.org/2020/preparing-final-manuscript/>) and your paper will not be published unless the following are done:

1. Revise your paper(s) according to the reviewers' comments. The detail review is listed in the below of thus email.
2. The accepted similarity level is maximum 20% which you may check using Turnitin or other similar plagiarism check.
3. Format your camera-ready paper as per guidelines and follow strictly the A4-IEEE format in pdf file by creating it using IEEE pdf express. (<https://www.pdf-express.org/plus>)
4. Fill the registration form that can be accessed from the website (<https://icic-aptikom.org/2020/#registration>) and submit it to co including the proof of your payment and proof of student status when it is relevant.
5. Send your camera-ready paper (in MS Word and PDF) also the presentation file to forms.gle/mPN3biujstQRVY8p9.
6. Electronic IEEE copyright form will be sent to the correspondent e-mail for each of your accepted paper.

Please be reminded that the due date for early bird registration is 15 October 2020. At least one author has to register for the conference.

The conference will take place by VIRTUAL from 3rd – 4th November 2020. As soon as the schedule is completed, it will be posted on the conference website.

All related conference materials can be found at <https://icic-aptikom.org/> Please let us know if you have any questions regarding registration.

With a warmest regard,

Technical Program Chairs  
Achmad Nizar Hidayanto  
Husni Teja Sukmana  
Prihandoko

SUBMISSION: 118

TITLE: Investigating the Impact of System and Service Qualities on Customer Loyalty in Acceptance of E-Marketplace

----- REVIEW 1 -----

SUBMISSION: 118

TITLE: Investigating the Impact of System and Service Qualities on Customer Loyalty in Acceptance of E-Marketplace  
AUTHORS: Fx Hendra Prasetya, Bernardinus Harnadi, Agus Nugroho and Albertus Widianoro

----- Overall evaluation -----

SCORE: 2 (accept)

----- TEXT:

This paper aims to investigate the influence of System and Service Quality on Customer Loyalty in their acceptance of e-marketplaces.

----- REVIEW 2 -----

SUBMISSION: 118

TITLE: Investigating the Impact of System and Service Qualities on Customer Loyalty in Acceptance of E-Marketplace  
AUTHORS: Fx Hendra Prasetya, Bernardinus Harnadi, Agus Nugroho and Albertus Widianoro

----- Overall evaluation -----

SCORE: 2 (accept)

----- TEXT:

Below are my comments on this paper:

1. Congratulation to the authors for this paper that has been written well.
2. Please discuss the research gaps clearly in the introduction section.
3. Add the e-commerce context when developing the hypotheses.
4. Please add discussion and implications of your findings both on practices and theories.

---

**Fx. Hendra Prasetya** <hendra@unika.ac.id>  
To: Bermardinus Harnadi <bharnadi@unika.ac.id>

Tue, Dec 1, 2020 at 10:52 AM

[Quoted text hidden]

--

Powered by [unika.ac.id](https://unika.ac.id) mail service

Dokumen pendukung luaran Tambahan #2

Luaran dijanjikan: Publikasi Ilmiah Jurnal Internasional

Target: submitted

Dicapai: Submitted

Dokumen wajib diunggah:

1.

Dokumen sudah diunggah:

1. Naskah artikel

Dokumen belum diunggah:

-

Nama jurnal: Online Information Review

Peran penulis: first author | EISSN: 1468-4527

Nama Lembaga Pengindek: Scopus

URL jurnal: <https://www.emerald.com/insight/publication/issn/1468-4527>

Judul artikel: An Investigation of the Acceptance of Online Entertainment Technologies in Indonesia



**An Investigation of the Acceptance of Online Entertainment Technologies in Indonesia**

Journal:	<i>Online Information Review</i>
Manuscript ID	Draft
Manuscript Type:	Research Paper
Keywords:	behavior, culture, habit, online entertainment technology, acceptance

SCHOLARONE™  
Manuscripts

# An Investigation of the Acceptance of Online Entertainment Technologies in Indonesia

## Abstract

**Purpose** - This research investigates acceptance of online entertainment technology based on the role of Habit as a mediator and Age, Gender, and Cultural factors as moderating variables on the acceptance.

**Design/methodology/approach** - The theoretical model was employed to examine the causal effect on acceptance as well as moderating effects of the factors. The theoretical model was tested with online entertainment consumers and evaluated using structural equation modeling and the results confirmed several findings and new findings which are not stated in previous researches.

**Findings** - The findings confirm the positive and direct effect of Behavioral Intention due to Habit and Price Value and Habit due to Hedonic Motivation and Social influence. New findings derived from moderating effect analysis show that Age, Individualism-Collectivism, and Feminism-Masculinity have moderating effects on Behavioral Intention due to Habit. Moreover, Gender and Uncertainty Avoidance have moderating effects on the Habit due to Hedonic Motivation.

**Originality/value** - This research contributes to not only the literature of online entertainment acceptance by integrating Habit as a mediator on the acceptance but also the literature concerning the hypothesis by composing evidence of Age, Gender, and Culture differences in the acceptance. Furthermore, this research serves practical insight into: parents and educators who need to know the characteristics of consumers of online entertainment; practitioners who need to know the segmentation and targeting regarding the differences of the consumers; and the online entertainment application developers regarding how to design the applications to satisfy the consumers of different ages, genders, and cultures.

**Keywords** - behavior, culture, habit, online entertainment technology, acceptance

**Paper type** Research paper

## 1. Introduction

According to Special Reports, Digital 2020 by Kemp [1], the total population of the world is 7.79 billion where 4.57 billion of them are internet users; and 5.15 billion of them are unique mobile phone users. Online entertainment is one of the most popular activities, especially during the Covid-19 pandemic. Kemp said that 7 in 10 mobile phone users had spent more time in their daily activities compared to the pre-pandemic levels. For example, there was an increase of 57 percent in watching streaming shows and movies, 47 percent in using social media, 46 percent in using messaging services, and 39 percent in streaming music services. The time spending on using social media and messaging services in the Y and Z generations were greater than the previous generation. In Indonesia, the number of internet users was 175.4 million in January 2020. It increases by 17 percent (25 million) compared to 2019. At the same time, the mobile connections were 338.2 million, and the connections increased by 4.6 percent (15 million) compared to 2019 [2]. The Y and Z generations as digital natives have a greater tendency to use technology because they have been familiar with these technologies in their daily lives since childhood. Their adaptation and instincts grow faster to adapt to the various things related to technology naturally (Sorgo, 2016). With an extensive of young people accept online technology especially online entertainment technology, the research on acceptance of the technology associating with gender and age differences has become even more important for technology developers and their consumers (Chawla, 2020; Chen, 2018; Harnadi, 2017; Wang and Sun, 2016; Lee, 2009; Akbar, F., 2013; Venkatesh et al. 2012; Venkatesh et al. 2003). Moreover, the researches on cultural differences on the acceptance of the technology were still limited (Tarhini et al., 2016; Alshare and Mousa, 2014), with the result that the consumers' and developers' insight on this problem are limited too. The research needs to be done to fulfill this gap.

The purpose of this research is to investigate the acceptance of online entertainment technology in Indonesia by examining variables related to the acceptance of online music, online gaming, video streaming, online comics, and online news. The research addresses these two research questions: First, which factors influence an individual's intention to accept online entertainment in Indonesia? Second, which relationships represent significant causal effects and which represent significant moderation effects on the intention? The questions lead to investigate the role of age, gender, and cultural factors on the acceptance of online entertainment technology.

The research model is proposed and questionnaires data was collected from a sample of 1121 individuals aged 14 – 24 years from three cities in Indonesia to be analyzed to gain the findings. The related literature regarding online entertainment studies comes from gaming studies (Chen, 2018; Harnadi, 2017; Merikivi, 2017; Wang and Sun, 2016;

Wei and Lu, 2014; Fan et al., 2012; Lee, 2009). The other literature comes from e-commerce studies (Merhi et al., 2020; Baabdullah et al., 2019; Khatimah, et al., 2019; Chopdar et al., 2018; Alalwan et al., 2018) and technology acceptance studies (Tarhini et al., 2016; Alshare & Mousa, 2014; Akbar, F., 2013; Venkatesh et al., 2012; Venkatesh et al., 2003).

There were limited researches conducted on moderating the effect of culture on acceptance of technology (Tarhini et al., 2016; Alshare and Mousa, 2014; Straub, 1997). Straub (1997) conducted research that employed cultural factors naming Power Distance, Individualism, Feminism, and Uncertainty Avoidance as moderator variables. Meanwhile, Tarhini et al. (2016) employed Power Distance, Feminism, and Uncertainty Avoidance and Alshare & Mousa (2014) only employed Power Distance and Individualism as moderator variables. The related literature on e-commerce and organization contexts conducting Habit as a predictor on Behavioral Intention also limited such as research conducted by Khatimah, et al. (2019), Chopdar et al. (2018), and Venkatesh et al. (2012).

Drawing upon the selectivity hypothesis, which argues that hedonic motivation and social interaction of customers drives the individual' habit in using online entertainment (Khatimah, et al., 2019) and the habit establishes the acceptance of online entertainment (Khatimah, et al., 2019; Chopdar et al., 2018; Venkatesh et al., 2012), we propose that hedonic motivation and social influence can drive the individual' habit and then accept online entertainment. Furthermore, the hypothesis argues that male and female consumers have different habits and hedonic motivations regarding their acceptance (Venkatesh et al., 2012). The hypothesis also argues that young and adult consumers have a different mode of habit in their acceptance (Venkatesh et al., 2012). Eventually, we propose consumers of different gender and age will respond to different habits and acceptance in using online entertainment. Moreover, consumers of different ages respond to the different hedonic motivations in using online entertainment. Furthermore, we propose consumers with different culture naming Power Distance, Individualism, Feminism, and Uncertainty Avoidance will respond to different perception in using online entertainment.

To test the related hypothesis, we conduct a study on the causal effect of Habit and other factors related to previous research including Hedonic Motivation, Price Value, and Social Influence on Behavioral Intention to use online entertainment technology and also investigate the role of age, gender and cultural factors as a moderator on Habit and Behavioral Intention. The findings of the research regarding full or partial support for the hypotheses are derived from previous studies. Consequently, the finding has not highlighted any new findings related to direct causal effects on Behavioral Intention. New Findings regarding the role of age, gender, and culture on the individual's habit and intention to accept online entertainment are gained from moderation analysis on the Habit and Behavioral Intention. New findings contribute to not only the existing online entertainment literature by incorporating the moderating role of age, gender, and culture in accepting online entertainment, but also the literature relating the selectivity hypothesis by delivering evidence of age, gender, and cultural differences in acceptance of online entertainment. Besides, the practical implication of the new findings associated with the moderating effects of Age, Gender, and Culture offers marketing managers and developers practical insight into how to design attractive online entertainment applications to gratify consumers of different ages, gender, and culture.

This paper begins with a review of related literature in Section 2, we review the related literature on Behavioral Intention in the context of online entertainment technology, e-commerce technology, and technology acceptance in general and on moderating effect of age, gender, and culture. This is followed by a proposed theoretical model and hypotheses in Section 3. Section 4 presents the research methodology. We perform data analysis and results in Section 5. Section 6 discuss the findings and new findings and conclude with implication, limitations, and possible further work. The last, Section 7 presents the conclusion of this research.

## 2. Overview of Literatures

### 2.1 Research Variables

The variables utilized in this research are presented in Table 1 providing the operational definition of the variables in this research.

**Table 1. Operational definition of research variables**

Variables	Operational Definitions	Reference
Hedonic motivation	The extent to which an individual perceives that playing online media entertain is fun or pleasure.	Venkatesh et al. (2012)
Habit	The extent to which people tend to perform behaviors automatically because of learning and their behaviors was the result of prior experiences.	Venkatesh et al. (2012)
Social Influence	The degree to which an individual perceives that important others believe that they should use the system.	Venkatesh et al. (2003)

Variables	Operational Definitions	Reference
Price Value	The extent to which 'consumers' cognitive tradeoff between the perceived benefits of the applications and the monetary cost for using them.	Venkatesh et al. (2012)
Behavioral Intention	The extent to which the user intends to play online entertainment in the future.	Harnadi (2017)
Gender	The individual's gender is measured as male or female.	Nil
Age	The individual's age in years.	Nil
Power Distance	The extent to which individuals expect and accept differences in power between different people.	Tarhini et al. (2016)
Individualism-Collectivism	The extent to which individuals are integrated into groups.	Tarhini et al. (2016)
Feminism-Masculinity	The extent to which traditional gender roles are differentiated.	Tarhini et al. (2016)
Uncertainty Avoidance	The extent to which ambiguities and uncertainties are tolerated.	Tarhini et al. (2016)

The reviews of related researches on related researches on online entertainment, e-commerce, and technology acceptance are displayed in Table 2.

**Table 2. Previous Researches of Behavioral Intention (BI) in the context of online entertainment, e-commerce, and acceptance of technology**

Model/Theory	Causal Effects on BI	Moderating Effects	Data Collection	Reference
<b>Research in the Context of Online Entertainment</b>				
U & G Expectancy model in mobile English learning games acceptance	Gratification	<b>Gender</b> as a moderator of the effect of Gratification on Continue Intention	Quantitative survey	Chen (2018)
Extended UTAUT model in online gaming acceptance	Perceived Enjoyment, Performance Expectancy, Facilitating Conditions	<b>Age</b> as a moderator of the effect of Effort Expectancy on BI. <b>Gender</b> as a moderator of the effect of Performance Expectancy on BI	Quantitative survey	Harnadi (2017)
ETAM in digital game acceptance of the elderly	Game Narrative, Social Interaction, Physical Condition, Perceived Ease of Use, Attitude	<b>Age</b> as a moderator of the effect of Perceived Ease of Use on BI. <b>Gender</b> as a moderator of the effect of Perceived Ease of Use on BI. <b>Experience</b> as moderator of the effect of Perceived Ease of Use and Attitude on Intention	Quantitative survey	Wang and Sun (2016)
Investigating factors that influence people to play mobile social games	Enjoyment, Interaction with others, perceived number of users, perceived number of peers, Time flexibility	None	Quantitative web survey	Wei and Lu (2014)
Antecedents of users' intentions to play online games using TAM and TPB	Flow, Subjective norm, Perceived usefulness, Perceived ease of use	None	Quantitative survey	Fan et al. (2012)
Examining two competing models based on TPB and	Flow Experience, Perceived Enjoyment, Attitude, Subjective	<b>Gender</b> as a moderator of the effect of Perceived Enjoyment on BI, Attitude on BI, human-	Quantitative web survey	Lee (2009)



Model/Theory	Causal Effects on BI	Moderating Effects	Data Collection	Reference
TAM	Norms, Perceived Behavioral Control	computer interaction to flow experience. <b>Experience</b> as moderator of the effect of Perceived Behavioral Control on BI		
<b>Research in the Context of E-commerce Technology</b>				
The role of age and gender in consumer mobile banking use	Performance Expectancy, Effort Expectancy, Price Value, Perceived Security, Facilitating Conditions, Trust	<b>Age</b> as a moderator of the effect of Habit, Hedonic Motivation, Price Value on BI. <b>Gender</b> as a moderator of the effect of Price Value on BI.	Quantitative survey	Merhi et al. (2020)
Investigating consumer use of mobile banking	Performance Expectancy, Facilitating Conditions, Hedonic Motivation, Price Value, Habit, Service Quality, System Quality	None	Quantitative survey	Baabdullah et al. (2019)
The role of payment habit as a mediator on user acceptance of e-money	Habit	None	Quantitative survey	Khatimah et al. (2019)
Investigating factors predicting mobile shopping acceptance	Performance Expectancy, Effort Expectancy, Facilitating Conditions, Hedonic Motivation, Price Value, Habit, Privacy Risk	None	Quantitative survey	Chopdar et al. (2018)
Examining factors influencing acceptance of mobile banking	Perceived Risk, Hedonic Motivation, Price Value, Performance Expectancy, Effort Expectancy	None	Quantitative survey	Alalwan et al. (2018)
<b>Research in the Context of Acceptance of Technology</b>				
Moderating effect of individual-level culture values on the user's acceptance of E-learning	Perceived Ease of Use, Perceived Usefulness, Subjective Norms, Quality of Work Life	<b>Power Distance</b> as moderator of the effect of Subjective Norms on BI, Perceived Usefulness on BI. <b>Individualism</b> as moderator of the effect of Subjective Norms on BI. <b>Uncertainty Avoidance</b> as moderator of the effect of Subjective Norms on BI	Quantitative survey	Tarhini et al. (2016)
Moderating effect of Espoused Cultural Dimensions on Consumer's acceptance to use the mobile payment device	Performance Expectancy, Social Influence, Perceived Information Security	<b>Collectivism</b> as moderator of the effect of Social Influence on BI. <b>Uncertainty Avoidance</b> as moderator of the effect of Effort Expectancy on Performance Expectancy and Perceived Information Security on BI. <b>Masculinity</b> as moderator of the effect of Performance Expectancy on BI	Quantitative survey	Alshare & Mousa (2014)

Model/Theory	Causal Effects on BI	Moderating Effects	Data Collection	Reference
Students' acceptance and use of technology in an academic environment	Performance Expectancy, Attitude	<b>Age</b> as a moderator of the effect of Performance Expectancy, Effort Expectancy, and Social Influence on BI. <b>Gender</b> as a moderator of the effect of Performance Expectancy, and Effort Expectancy on BI. <b>Experience</b> as a moderator of the effect of Perceived Ease of Use and Attitude on Intention	Quantitative survey	Akbar, F. (2013)
Investigating consumer acceptance and use of technology based on Extended UTAUT model	Performance Expectancy, Effort Expectancy, Social Influence, Facilitating Conditions, Hedonic Motivation, Price Value, Habit	<b>Age</b> as a moderator of the effect of Performance Expectancy, Effort Expectancy, Social Influence, Facilitating Conditions, Hedonic Motivation, Price Value, and Habit on BI. <b>Gender</b> as a moderator of the effect of Performance Expectancy, Effort Expectancy, Social Influence, Facilitating Conditions, Hedonic Motivation, Price Value, and Habit on BI. <b>Experience</b> as a moderator of the effect of Effort Expectancy, Social Influence, Hedonic Motivation, and Habit on BI.	Quantitative survey	Venkatesh et al. (2012)
UTAUT model	Performance Expectancy, Effort Expectancy, Social Influence	<b>Age</b> as a moderator of the effect of Performance Expectancy, Effort Expectancy, and Social Influence on BI. <b>Gender</b> as a moderator of the effect of Performance Expectancy, Effort Expectancy, and Social Influence on BI. <b>Experience</b> as a moderator of the effect of Effort Expectancy and Social Influence on BI	Quantitative survey	Venkatesh et al. (2003)

According to data in Table 2, almost all of the research of behavioral intention in the context of online entertainment, e-commerce, or technology acceptance propose a theoretical model with hypotheses were examined using quantitative data collected using a questionnaire. The several models in TAM, TPB, Extended-TAM, UTAUT, and Extended-UTAUT are used extensively. However, there are a few research that investigates moderating effects and specifically, none of these have been conducted in Indonesia.

## 2.2 Hedonic Motivation, Habit, and Behavioral Intention

Hedonic Motivation is an interesting factor in acceptance research, which divides into Perceived Enjoyment (PE) and Flow Experience (FE). On the research of acceptance to use technology, Harnadi (2017), Wei and Lu (2014), Luo et al. (2011), Koo (2009) and Lee (2009) employed PE and Harnadi (2017), Fan et al. (2012), and Koo (2009) employed FE as predictors on Behavioral Intention (BI). PE also acted as a predictor on Use Behavior according to

1  
2  
3 Merikivi (2017), meanwhile, Luo et al. (2011) employed Entertainment as a predictor on Use Behavior. Venkatesh  
4 et al. (2012) employed Hedonic Motivation as a predictor on BI.

5 According to Harnadi (2017), Koo (2009), and Lee (2009), PE has a statistically significant direct effect on BI. Luo  
6 et al. (2011) conducted a study on information service adoption and they derived the result that PE has also a  
7 statistically significant direct effect on Attitude and Attitude on BI. In the relation of FE and BI, several types of  
8 research resulted in the analysis where FE has a statistically significant direct effect on BI according to Fan et al.  
9 (2012) and Koo (2009). Moreover, Koo (2009) employed Escape, and Harnadi (2017) concluded in his study that  
10 FE has a partially significant direct effect on BI.

11 Research employing Hedonic Motivation as a predictor on Habit conducted by Khatimah, et al. (2019). The research  
12 also employed Social Influence as a predictor of Habit. It resulted in the Hedonic Motivation and Social Influence  
13 have a statistically significant direct effect on Habit.

14 Habit is also an interesting factor in the acceptance to use e-commerce technology and to use technology in general.  
15 Khatimah, et al. (2019), Chopdar et al. (2018), and Venkatesh et al. (2012) employed Habit as the predictor on  
16 Behavioral Intention, and Baabdullah et al. (2019) and Venkatesh et al. (2012) employed Habit as the predictor on  
17 Use Behavior. The result stated that Habit has a statistically significant direct effect on BI (Khatimah, et al., 2019;  
18 Chopdar et al., 2018; Venkatesh et al., 2012) and has a statistically significant direct effect on Use Behavior  
19 (Baabdullah et al., 2019; Venkatesh et al., 2012). Based on these reviews, we propose that:

20 H1: Hedonic Motivation has a statistically significant direct effect on Behavioral Intention to use online  
21 entertainment.

22 H2: Hedonic Motivation has a statistically significant direct effect on Habit.

23 H3: Habit has a statistically significant direct effect on Behavioral Intention to use online entertainment.

### 24 **2.3 Social Influence and Behavioral Intention**

25 The results from researches conducted by Harnadi (2017), Wang and Sun (2016), Fan et al. (2012), Koo (2009), and  
26 Lee (2009) employed Social Norm, Social Interaction, and Social Affiliation as a predictor of BI. While other  
27 researchers Harnadi (2017) and Venkatesh et al. (2012) use Social Influence as the predictor of BI. Social  
28 Interaction and Social Affiliation are factors having close naming to Social Influence. To further elaborate,  
29 researches conducted by Wang and Sun (2016), Fan et al. (2012), Venkatesh et al. (2012), Koo (2009), and Lee  
30 (2009) concluded that Social Influence has a statistically significant direct effect on BI. Other researchers Harnadi  
31 (2017) and Akbar (2013) stated that Social Influence has a partially statistically significant direct effect on BI.

32 As a reference Khatimah, et al. (2019) stated previously, that concurrently with Hedonic Motivation, Social  
33 Influence has a statistically significant direct effect on Habit. Based on these reviews, we propose that:

34 H4: Social Influence has a statistically direct effect on Behavioral Intention to use online entertainment.

35 H5: Social Influence has a statistically direct effect on Habit.

### 36 **2.4 Price Value and Behavioral Intention**

37 Price Value (PV) is an interesting factor in the acceptance of e-commerce research. According to Chopdar et al.  
38 (2018), Alalwan et al. (2018), and Venkatesh et al., (2012), PV has a statistically significant direct effect on BI.  
39 Other research conducted by Baabdullah et al. (2019) also stated that PV has a statistically significant direct effect  
40 on Use Behavior. Based on these reviews, we propose that:

41 H6: Price Value has a statistically direct effect on Behavioral Intention to use online entertainment.

### 42 **2.5 Moderating Effect of Gender**

43 Gender is employed as a moderator on the relations of factors on the acceptance technology model. Works by Merhi  
44 et al. (2020), Chen (2018), Harnadi (2017), Wang & Sun (2016), Venkatesh et al. (2012), Lee (2009), Wang &  
45 Wang (2008), Venkatesh et al. (2003) examine gender as a moderating factor on online gaming acceptance and  
46 consumer acceptance researches. Table 5 summarizes the moderating effect of gender on the related research which,  
47 regarding the relation of Hedonic motivation on Behavioral Intention, Venkatesh et al. (2012) and Lee (2009) state  
48 that the hedonic motivation has a stronger effect on males compared to the females. Another researcher, Wang &  
49 Wang (2008) did similar research and concludes that the effect of gender does not differ between males and females.  
50 Two researchers, Lee (2009) and Venkatesh et al. (2003) present a different result on Gender as a moderator on the  
51 relation of social influence on Behavioral Intention. Venkatesh et al. (2003) state that the stronger effect was in  
52 females than males; Meanwhile, Lee (2009) concludes that Gender was not a significant moderator. Furthermore,  
53 Merhi et al. (2020) and Venkatesh (2012) use Gender as a moderator on the relation of Price Value and Habit on  
54 Behavioral Intention which resulting in a conclusion that Gender was a significant moderator on Price Value on  
55  
56  
57  
58  
59  
60

Behavioral Intention with a stronger effect in females than males. Gender is also considered as a significant moderator on Habit and Behavioral Intention with a stronger effect in males than females.

**Table 3. Moderating effects of Gender**

Causal effect on BI	Moderator	Reference	Context of the Study
Hedonic Motivation	The stronger effect on males than on the female (Perceived enjoyment)	Lee (2009)	Online gaming
	The stronger effect on males than on the female	Venkatesh et al. (2012)	Consumer Acceptance and Use of technology
	The effect did not differ among male and female (Perceived enjoyment)	Wang and Wang (2008)	Online gaming
	Gender was not a significant moderator (Flow experience)	Lee (2009)	Online gaming
Social influence	The stronger effect on females than on the male.	Venkatesh et al. (2003)	Technology acceptance
	Female was a significant moderator but not for males	Harnadi (2017)	
	Gender was not a significant moderator	Lee (2009)	Online gaming
Price value	The stronger effect on females than on the male.	Merhi et al. (2020)	Consumer mobile banking use
	The stronger effect on females than on the male.	Venkatesh et al. (2012)	Acceptance of mobile internet technology
Habit	The stronger effect on males than on the female.	Venkatesh et al. (2012)	Consumer Acceptance and Use of technology

## 2.6 Moderating Effect of Age

The works by Merhi et al. (2020), Harnadi (2017), Wang & Sun (2016), Akbar (2013), Venkatesh et al. (2012), Lee (2009), and Venkatesh et al. (2003) study the moderating of Age on the relation of factors on Behavioral Intention, summarized in Table 6. Venkatesh (2012) and Lee (2009) use Age as a moderator on the relation of Hedonic Motivation on Behavioral Intention and they came to a different conclusion. Merhi et al. (2020) and Venkatesh et al. (2012) conclude that Age was a significant moderator with a stronger effect on younger people than on older people, while Lee (2009) finds that Age was not a significant moderator.

Akbar (2013), Lee (2009), and Venkatesh et al. (2003) had studied the moderating effect of Age in the relation of Social Influence on Behavioral Intention, in which all of them have different results. Venkatesh (2003) finds that the effect is stronger on older people than on younger people, compared to Akbar's (2013) where the effect is stronger on younger people than older people. This differs from the research conducted by Lee (2009), which concludes that the effect of Age was not significant. Merhi et al. (2020) and Venkatesh et al. (2012) use Age as the moderator on the relation Price Value and Habit on Behavioral Intention and they came to a different conclusion. Merhi et al. (2020) conclude that Age was a significant moderator with a stronger effect on younger people than on older people, while Venkatesh et al. (2012) finds that a stronger effect was in older people than in younger people.

**Table 4. Moderating effects of Age**

Causal effect on BI	Moderator	Reference	Context of the Study
Hedonic Motivation	The stronger effect in younger people than in older people.	Merhi et al. (2020)	Consumer mobile banking use
	The stronger effect in younger people than in older people.	Venkatesh et al. (2012)	Consumer Acceptance and Use of technology
	Age was not a significant moderator	Lee (2009)	Online gaming
Social Influence	The stronger effect in older people than in younger people.	Venkatesh et al. (2003)	Technology acceptance
	The stronger effect in younger people than in older people.	Akbar (2013)	Technology acceptance on the academic environment

Causal effect on BI	Moderator	Reference	Context of the Study
	Age was not a significant moderator	Lee (2009)	Online gaming
Price Value	The stronger effect in younger people than in older people.	Merhi et al. (2020)	Consumer mobile banking use
	The stronger effect in older people than in younger people.	Venkatesh et al. (2012)	Consumer Acceptance and Use of technology
Habit	The stronger effect in younger people than in older people.	Merhi et al. (2020)	Consumer mobile banking use
	The stronger effect in older people than in younger people.	Venkatesh et al. (2012)	Consumer Acceptance and Use of technology

## 2.7 Moderating Effect of Culture

According to Straub (1997), there are four culture dimensions used to examine their impact on technology acceptance known Hofstede's cultural dimensions which comprise Power Distance (PD), Individualism-Collectivisms (I-C), Femininity-Masculinity (F-M), and Uncertainty Avoidance (AU). The cultural researches of this technology acceptance come from the e-learning context by Tarhini et al. (2016) and mobile payment device context by Alshare & Mousa (2014) where the four dimensions were employed as a moderator on the relation of factors on Behavioral Intention. Table 7 summarizes This moderating effect of culture on the related researches in which Tarhini et al. (2016) state that PD was a significant moderator on the relation of Performance Expectancy and Social influence on Behavioral Intention; I-C was a significant moderator on the relation of Effort Expectancy on behavioral Intention; both F-M and I-C were significant moderators on the relation of Performance Expectancy and Effort Expectancy. Meanwhile, Alshare & Mousa (2014) states that PD and I-C were significant moderators on the relation of Social Influence on Behavioral Intention and F-M was a significant moderator on the relation of Performance Expectancy on Behavioral Intention.

**Table 5. Moderating effects of Culture**

Causal effect on BI	Moderator	Reference	Context of the Study
Moderating effects of Power Distance			
Social influence	The stronger effect in Larger PD than in Smaller PD	Tarhini et al. (2016)	E-Learning
	PD was not a significant moderator	Alshare and Mousa (2014)	Mobile Payment Device
Moderating effects of Individualism			
Social influence	The stronger effect in Collectivism than in Individualism	Alshare and Mousa (2014)	Mobile Payment Device
Moderating effects of Masculinity			
Social influence on behavioral intention	The stronger effect in Femininity than in Masculinity	Tarhini et al. (2016)	E-Learning
Moderating effects of Uncertainty Avoidance			
Social influence	The stronger effect in Higher UA than in Lower UA	Tarhini et al. (2016)	E-Learning

On the moderating effects of PD on the relation of Social Influence on Behavioral Intention, Tarhini et al. (2016) and Alshare and Mousa (2014) each have a different result. According to Tarhini et al. (2016), PD is a significant moderator that has a stronger effect in higher PD than in lower PD. Meanwhile, Alshare and Mousa (2014) state that PD was not a significant moderator. Alshare & Mousa (2014) also investigates the mobile payment devices that resulted in I-C as a significant moderator on the relation of Social Influence on Behavioral Intention where its effect is stronger in Collectivism than Individualism. Tarhini et al. (2016) examine the moderating effects of F-M on the relation of Social Influence on Behavioral Intention; the result is that the stronger effect was in Femininity than Masculinity. To complete the results, Tarhini et al. (2016) examine AU as a moderating effect of Social Influence on Behavioral Intention; it concludes in the finding that higher UA is affected stronger than UA.

### 3. Proposed Theoretical Model and Hypotheses

Figure 1 presents the proposed theoretical model derived from the findings in previous studies. The causes and effects in the model are associated with research hypotheses and the measurement of variables is discussed in this section.

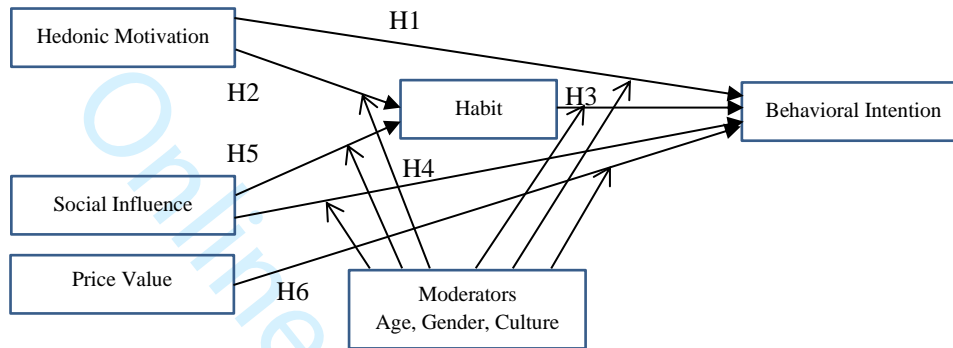

Figure 1. Proposed Theoretical Model

### 4. Research methodology

Based on the theoretical model explained in the previous section, it is possible to build a questionnaire with two parts. The first part is used to collect demographic data of the respondents, including gender, age, and experience. The second is to capture the respondent's perception of the five latent variables on the model that are Hedonic Motivation, Social Influence, Habit, Price Value, and Behavioral Intention and four cultural factors naming Power Distance, Individualism, Masculinity, and Uncertainty Avoidance. Ten high schools and university students representing the Y and Z generation are tested respectively with the questionnaire to get improvement suggestions. The questionnaire was spread to three cities in Indonesia: Jakarta, Bali, and Semarang; the cities where the hard and soft questionnaires with printed paper and Google form respectively are spread. Additional questionnaires were also spread out to the researcher's contacts in two regions: Kalimantan and Sumatra Island via Google form.

Respondents returned 1163 questionnaires in which will be entered and processed into SPSS. Among the 1163 questionnaires, twenty-one needs to be eliminated because of the missing values, and ten more questionnaires were eliminated because of their out-of-range values. Furthermore, eleven questionnaires were removed as they have an outlier measure for the model variables. Consequently, 1121 questionnaires were the final sample size to be analyzed using SEM to ensure statistical validity and reliability, and other techniques were applied in the analysis and development of the proposed theoretical model.

### 5. Data analysis and results

#### 5.1 Descriptive Data Analysis

Tables 6, 7, 8, and 9 present the demographic and behavioral factors of respondents. Table 6 shows most of the respondents (41.6 percent) come from the city of Bali and the remaining respondents come from cities Semarang and Jakarta and two island areas Kalimantan and Sumatera. They usually use video streaming (50.9 percent) as their online entertainment application, be followed by online music (22.4 percent) and online gaming (17.8 percent), and the remaining respondents (8.9 percent) use online comics and online news.

The demographic of Respondent in Table 7 shows that most of them are in the range of 15-19 years old or Z Generation (82.5 percent). From the Table, it is seen that most of the respondents (55 percent) were females. The majority of respondents (72.3 percent) have completed high school as their highest level of education or they are currently enrolled at high school. The remaining respondents have either completed a bachelor's degree or are currently registered for a bachelor's degree with other respondents who have either completed or are currently registered for a master's degree.

Table 6. Regions and Cities of Respondent and applications they frequently use

City	Freq.	%	Online Application	Freq.	%
Semarang	373	33.3	Online Music	251	22.4
Bali	466	41.6	Online Gaming	199	17.8

City	Freq.	%	Online Application	Freq.	%
Jakarta	204	18.2	Video Streaming	571	50.9
Sumatera	13	1.2	Online Comic	53	4.7
Kalimantan	65	5.8	Online News	47	4.2
Total	1121	100.0	Total	1121	100.0

In this research, Age is employed as a moderating effect on each of the three causal effects of Hedonic Motivation, Social Influence, Price Value, and Habit on Behavioral Intention and two causal effects of Hedonic and Social Influence on Habit. Consequently, to analyze these moderating effects the participants are divided into two age groups: (a) Y generation, those of age older than 19 years (82.5 percent); and (b) Z generation, those of age 19 years or less (17.5 percent).

**Table 7. Age, Gender, Education, and Generation of Respondent**

Age	Freq.	%	Gender	Freq.	%
15	234	20.9	Male	504	45.0
16	293	26.1	Female	617	55.0
17	265	23.6	Total	1121	100.0
18	55	4.9	Generation	Freq.	%
19	78	7.0	Z	925	82.5
20	69	6.2	Y	196	17.5
21	57	5.1	Total	1121	100.0
22	28	2.5	Education	Freq.	%
23	22	2.0	High School	810	72.3
24	20	1.8	College	291	26.0
Total	1121	100.0	others	20	1.8
			Total	1121	100.0

According to data presented in Table 8, the mobile phone is the most popular device (90.7 percent) to access online entertainment and most of them access it from home (93 percent) than other places likes school/college and net cafe.

**Table 8. Location and devices frequently used by Respondent**

Devices	Freq.	%	Location	Freq.	%
Mobile Phones/Tablets	1017	90.7	Home	1042	93.0
Laptop/PC	96	8.6	School/College	67	6.0
Console	8	.7	Net Café	12	1.1
Total	1121	100.0	Total	1121	100.0

These behavioral factors regarding experience and the time respondents spent using online entertainment are shown in Table 9. Most of them have experience using online entertainment for over three years (75.6 percent), and on average, using it five times a week (80.9) and over three hours daily (40.7 percent).

**Table 9. Behavioral Factor, Experience, and Time Respondents spent using online media entertain**

Experience	Freq.	%	Day/Week	Freq.	%	Hour/Day	Freq.	%
<= 6 months	26	2.3	once a week	43	3.8	< 30 minutes	46	4.1
6 - 12 months	28	2.5	twice a week	34	3.0	30 - 60 minutes	166	14.8
1 - 1.5 years	51	4.5	three a week	74	6.6	1 - 2 hours	234	20.9
1.6 - 2 years	32	2.9	four times a week	63	5.6	2 - 3 hours	219	19.5
2.1 - 2.5 years	51	4.5	five times a week	907	80.9	> 3 hours	456	40.7
2.5 - 3 years	86	7.7	Total	1121	100.0	Total	1121	100.0
>= 3 years	847	75.6						
Total	1121	100.0						

## 5.2 Data Analysis

The theoretical model using construct Validity of measure for the latent variables was examined using Principal Component Factor analysis, while Cronbach's Alpha Coefficient measures the equivalent reliability of indicators. Table 10 shows the result of validity and reliability, which shows that all indicators are satisfactory construct validity with factor loadings of magnitude greater than 0.4 and has eigenvalues greater than 1. All indicators on the latent variable prove to be acceptable, good, and excellent as shown in table 10.

**Table 10. Construct Validity and Equivalent Reliability of indicators**

	HB-BI	HM	SI	PV	Cronbach's Alpha
HB1	.590	.343	.085	.225	.726 Acceptable
HB2	.661	.224	.146	.136	
HB3	.649	.120	.133	-.095	
BI1	.771	.180	.180	.270	.911 Excellent
BI2	.806	.136	.127	.259	
BI3	.772	.161	.187	.274	
HM1	.162	.831	.161	.134	.846 Good
HM2	.142	.818	.218	.105	
HM3	.166	.840	.103	.148	
SI1	.118	.197	.853	.104	.809 Good
SI2	.062	.155	.879	.141	
SI3	.193	.091	.693	.259	
PV1	.087	.233	.155	.716	.756 Acceptable
PV2	.063	.078	.193	.820	
PV3	.215	.082	.141	.786	

Table 11 shows the correlation coefficient among variables in the theoretical model. This coefficient was used to assign the profile of respondents and variables in the model. Table 11 states that:

1. A significant positive correlation ( $p < 0.05$ ) among variables was found on Experience, Hour/Day, Hedonic Motivation, Social Influence, Price Value, Habit, and Behavioral Intentions. It means that the high/low variables correlate with the high/low variables they associated.
2. Age only positively correlates ( $p < 0.05$ ) to Education, Social Influence, Price Value, and Behavioral Intentions. Meanwhile, Education has a significant negative correlation to Experience and a significant positive correlation to Social Influence.
3. All relations in the theoretical model to be a significant positive correlation on variables employed on it.

**Table 11. Correlation coefficient among variables**

	A											
A	1	Edu										
Edu	.812**	1	Exp									
Exp	-.037	-.087**	1	D/W								
D/W	-.022	-.021	.244**	1	H/D							
H/D	-.050	-.027	.282**	.335**	1	HM						
HM	.021	-.006	.092**	.071*	.213**	1	SI					
SI	.104**	.062*	.059*	.026	.118**	.396**	1	PV				
PV	.109**	.031	.106**	.042	.119**	.348**	.419**	1	HB			
HB	.018	-.004	.115**	.130**	.295**	.408**	.325**	.334**	1	BI		
BI	.088**	.045	.169**	.168**	.302**	.413**	.379**	.425**	.587**	1		

\*\* . Correlation is significant at the 0.01 level (2-tailed).

\* . Correlation is significant at the 0.05 level (2-tailed).

### 5.3 Causal Effect Analysis

The causal effect analysis was done by AMOS software, and Figure 1 shows its result of the SEM analysis as presented on the following format:

1. The first thing shown is the data with unstandardized effect, followed by its statistical significance using \*, \*\*, and \*\*\* to express its significance at a level of 0.05, 0.01, and 0.001, respectively. NS indicates the data is not significant statistically at a level of 0.05 or less; and



2. In the parentheses, data with the standardized effect is shown first, followed by the interpretation of its magnitude as Cohen (1988) described, small (S), medium (M), or large (L) with magnitude less than 0.1, 0.1 to less than 0.5, and 0.5 or greater respectively

Figure 1 shows two effects on Behavioral Intention Hedonic due to Motivation and Social Influence are positive, small, but not statistically significant at the level of 0.005 or less. Conversely, the two effects on Habit due to Hedonic Motivation and Social Influence have a positive, medium, and statistically significant. The other two effects on Behavioral Intention due to Habit and Price Value also have a positive, large, and statistically significant and positive, medium, and statistically significant, respectively. The fit statistic for the theoretical model was shown in Table 12. From the table, the theoretical model has fit statistics that are very satisfactory, as suggested by Kline (2005). The satisfactory proportion of the variance in Behavioral Intention ( $R^2 = 56$  percent) and Habit ( $R^2 = 34$  percent) are explained by the three and two exogenous variables that affect it, respectively.

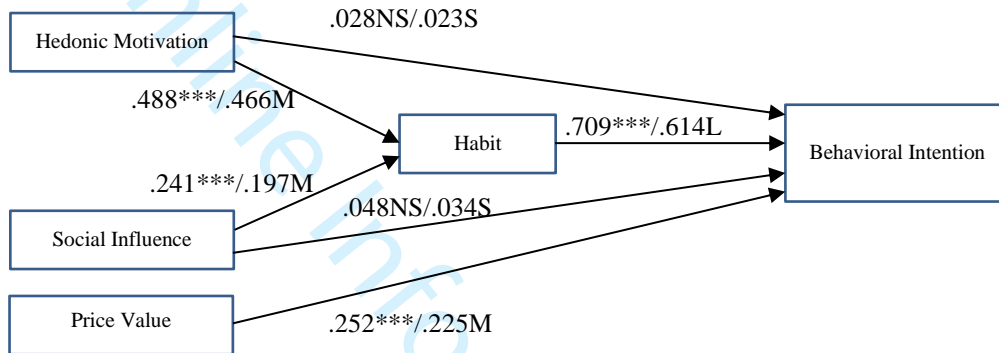

- a) \*\*\* means  $p < 0.001$  and NS means not statistically significant at 0.05 level or less
- b) S (Small), M (Medium), L (Large) standardized effects are those with magnitudes less than 0.1, 0.1 to less than 0.5, and equal to and more than 0.5, respectively.

Figure 2. Direct effects in the theoretical model

**Table 12. Fit statistics for the theoretical model**

Model	N	NC ( $\chi^2/df$ )	RMR	GFI	AGFI	NFI	IFI	CFI	RMSEA
Theoretical Model	1121	399.421/81 = 4.931	.041	.955	.934	0.951	0.961	0.961	0.059
<b>R<sup>2</sup>: HB (34 percent); BI (56 percent)</b>									

### 5.4 Moderating Effect Analysis

The moderating effect of Gender, Age, Power Distance, Individualism, Feminism, and Uncertainty Avoidance is examined based on the following groups; Gender in males (504) and females (617); Age in Z generation (925) and Y generation (196); Power Distance in higher PD (666) and lower PD (455); Individualism in individualism (253) and collectivism (868); Feminisms in feminisms (95) and Masculinity (1026); Uncertainty Avoidance in lower UA (40) and higher UA (1081). The moderating effect analysis was done using the Multi-Group Analysis feature of AMOS, and the detail of the analysis was shown in Table 13. Furthermore, the fit statistic for the theoretical model to each group in Gender, Age, PD, Individualism, Feminism, and AU was shown in Table 14.

**Table 13. Analysis of direct causal effects for groups in Gender, Age, PD, Individualism, Feminism, and AU**

Causal Direct Effect	Unstandardized Estimate	Statistical Significance	Standardized Estimate	Magnitude	Unstandardized Estimate	Statistical Significance	Standardized Estimate	Magnitude	
<b>Males (N = 504)</b>					<b>Females (N = 617)</b>				
HM→ HB	.347	***	.320	M	.588	***	.576	L	
SI→ HB	.331	***	.295	M	.176	NS	.129	M	
HB→ BI	.592	***	.534	L	.831	***	.701	L	
HM→ BI	.106	NS	.088	S	-.072	NS	-.059	S	
PV→ BI	.254	***	.262	M	.253	***	.109	M	
SI→ BI	.063	NS	.051	S	.025	NS	.016	S	
<b>Age of 14 – 19 / Z generation (N = 925)</b>					<b>Age of 20 – 24 / Y generation (N = 196)</b>				
HM→ HB	.463	***	.465	M	.579	***	.451	M	
SI→ HB	.256	***	.214	M	.147	NS	.101	M	
HB→ BI	.751	***	.626	L	.529	***	.558	L	
HM→ BI	.033	NS	.028	S	.003	NS	.002	S	
PV→ BI	.244	***	.218	M	.291	NS	.270	M	
SI→ BI	.021	NS	.014	S	.149	NS	.109	M	
<b>Higher Power Distance (N = 666)</b>					<b>Lower Power Distance (N = 455)</b>				
HM→ HB	.519	***	.482	M	.417	***	.428	M	
SI→ HB	.212	***	.179	M	.297	***	.237	M	
HB→ BI	.729	***	.615	L	.718	***	.630	L	
HM→ BI	.043	NS	.033	S	-.017	NS	-.015	S	
PV→ BI	.251	***	.221	M	.225	***	.205	M	
SI→ BI	.013	NS	.009	S	.142	NS	.100	M	
<b>Individualism (N = 253)</b>					<b>Collectivism (N = 868)</b>				
HM→ HB	.510	***	.490	M	.480	***	.455	M	
SI→ HB	.226	NS	.176	S	.253	***	.208	M	
HB→ BI	.583	***	.456	M	.738	***	.665	L	
HM→ BI	.261	NS	.196	M	-.044	NS	-.037	S	
PV→ BI	.228	NS	.184	M	.259	***	.242	M	
SI→ BI	.130	NS	.079	S	.021	NS	.016	S	
<b>Feminisms (N = 95)</b>					<b>Masculinity (N = 1026)</b>				
HM→ HB	.593	***	.561	L	.467	***	.444	M	
SI→ HB	.030	NS	.020	S	.260	***	.218	M	
HB→ BI	.331	NS	.327	M	.756	***	.644	L	
HM→ BI	.230	NS	.215	M	.017	NS	.014	S	
PV→ BI	.273	NS	.285	M	.243	***	.212	M	
SI→ BI	.284	NS	.192	M	.015	NS	.011	S	
<b>Lower UA (N = 40)</b>					<b>Higher UA (N = 1081)</b>				
HM→ HB	.012	NS	.016	S	.499	***	.460	M	
SI→ HB	.629	NS	.890	L	.230	***	.181	M	
HB→ BI	.592	NS	.345	M	.693	***	.619	L	
HM→ BI	.439	NS	.344	M	.019	NS	.016	S	
PV→ BI	.509	NS	.407	M	.242	***	.218	M	
SI→ BI	.108	NS	-.089	S	.049	NS	.035	S	

**Note:** \*, \*\*, and \*\*\* indicate statistical significance at a level of 0.05, 0.01, and 0.001, respectively and NS indicates not statistically significance at a level of 0.05 or less.

**Table 14. Fit statistics for groups in Gender, Age, PD, Individualism, Feminism, and AU**

Group	N	NC ( $\chi^2/df$ )	RMR	GFI	AGFI	NFI	IFI	CFI	RMSEA	R <sup>2</sup> (%)
<b>Gender</b>										
Males	504	230.717/81 = 2.848	.044	.943	.915	0.938	0.959	0.959	0.061	55.0
Females	617	268.390/81 = 3.313	.043	.947	.922	0.943	0.959	0.959	0.061	56.9
<b>Age</b>										
14–19 /Z generation	925	301.674/81 = 3.724	.036	.959	.940	0.953	0.965	0.965	0.054	55.3
20–24 /Y generation	196	215.073/81 = 2.655	.082	.867	.803	0.887	0.926	0.925	0.092	55.5
<b>Power Distance (PD)</b>										
Higher PD	666	285.144/81 = 3.520	.043	.947	.922	0.944	0.960	0.959	0.062	55.1
Lower PD	455	268.901/81 = 3.320	.046	.929	.895	0.918	0.942	0.941	0.071	58.7
<b>Individualism</b>										
Individualism	253	152.280/81 = 1.880	.057	.929	.895	0.920	0.961	0.960	0.059	51.2
Collectivism	868	334.437/81 = 4.129	.040	.951	.927	0.948	0.960	0.960	0.060	57.8
<b>Feminisms</b>										
Feminisms	95	143.076/81 = 1.766	.082	.834	.754	0.863	0.936	0.934	0.090	67.1
Masculinity	1026	352.868/81 = 4.356	.041	.957	.936	0.952	0.962	0.962	0.057	55.5
<b>Uncertainty Avoidance (UA)</b>										
Lower UA	40	160.534/81 = 1.982	.168	.676	.519	0.678	0.810	0.798	0.159	77.2
Higher UA	1081	371.987/81 = 4.592	.041	.957	.936	0.953	0.963	0.962	0.058	54.2

**Note:** R<sup>2</sup> is the proportion of the variance of the variable Behavioral Intention that is explained by the variables affecting it.

The differences in the magnitudes of causal effects between Groups are presented in the details in Table 15. The results in the Table suggest that Gender, Age, and Feminism-Masculinity have a significant moderating effect on Behavioral Intention due to Habit. Furthermore, Gender and Uncertainty Avoidance has a significant moderating effect on Habit due to Hedonic Motivation. Individualism-Collectiveness has a significant moderating effect on Behavioral Intention due to Hedonic Motivation. The Last, Power Distance does not have a significant moderating effect on all the causal effects.

**Table 15: Differences in the magnitudes of causal effects between Groups**

Causal Direct Effect	Magnitude of difference between effects	Critical Difference	Statistical Significance of Difference
<b>Gender (Males compared to Females)</b>			
HM→ HB	.241	2.54	**
SI→ HB	.155	1.55	NS
HB→ BI	.239	2.077	*
HM→ BI	.0179	1.853	NS
PV→ BI	.0001	.017	NS
SI→ BI	.038	.379	NS
<b>Age (Z compared to Y generations)</b>			
HM→ HB	.116	0.793	NS
SI→ HB	.109	0.718	NS
HB→ BI	.222	2.033	*
HM→ BI	.030	0.230	NS
PV→ BI	.047	0.466	NS
SI→ BI	.128	1.084	NS
<b>Power Distance (higher PD compared lower PD)</b>			
HM→ HB	.102	1.088	NS
SI→ HB	.085	0.815	NS
HB→ BI	.011	0.095	NS
HM→ BI	.060	0.633	NS
PV→ BI	.026	0.314	NS
SI→ BI	.129	1.197	NS
<b>Individualism (Individualism compared to Collectiveness)</b>			
HM→ HB	.030	0.268	NS
SI→ HB	.027	0.223	NS
HB→ BI	.155	1.164	NS
HM→ BI	.305	2.516	**
PV→ BI	.031	0.319	NS
SI→ BI	.109	0.874	NS
<b>Feminisms (Feminisms compared to Masculinity)</b>			
HM→ HB	.126	0.760	NS
SI→ HB	.230	1.133	NS
HB→ BI	.425	3.378	***
HM→ BI	.213	1.403	NS
PV→ BI	.030	0.225	NS
SI→ BI	.269	1.617	NS
<b>Uncertainty Avoidance (lower UA compared to higher UA)</b>			
HM→ HB	.487	2.498	*
SI→ HB	.399	1.655	NS
HB→ BI	.101	0.099	NS
HM→ BI	.420	1.664	NS
PV→ BI	.267	1.062	NS
SI→ BI	.157	0.217	NS

**Note:** \*, \*\*, and \*\*\* indicate statistical significance at a level of 0.05, 0.01, and 0.001, respectively and NS indicates not statistically significance at a level of 0.05 or less.

## 6. Discussions

### 6.1 The Respondents

The descriptive data show that the respondents of this research have sufficient experience and maturity to deliver reliable and valid responses to the questions regarding online entertainment. Following this description, the distribution of respondents on two groups on moderating factors was adequately more balance except for Age, Feminisms, and Uncertainty Avoidance. That is the limitation of the research related to the respondent balance to satisfy moderating analysis into each of two groups.

The correlation analysis suggests that the five variables, Hedonic Motivation, Social Influence, Price Value, Habit, and Behavioral Intention correlate with each other. Causal effect analysis combines the result to derive findings on the final model. Education, Social Influence, Price Value, and Behavioral Intentions have positively correlated to Age. As for the other variables, Education has a significant negative correlation to Experience and a significant positive correlation to Social Influence.

### 6.2 Causal Effects

The most influence on the extent to which the user intends to play online entertainment in the future (Behavioral Intention) is the extent to which people tend to perform behaviors automatically because of learning and the behaviors resulted from prior experiences (Habit). The next prominent is the extent to which 'consumers' cognitive tradeoff between the perceived benefits of the applications and the monetary cost for using them (Price Value)(Venkatesh et al., 2012). The statistically significant direct effect of Habit on Behavioral Intention is conformity with the finding by Khatimah (2019), Chopdar (2018), and Venkatesh et al. (2012). Meanwhile, the finding of Price Value has a statistically direct effect on Behavioral Intentions in conformity with the finding by Chopdar (2018), Alalwan (2018), Alshare and Mousa (2014), and Venkatesh (2012). Two variables Hedonic Motivation and Social Influence also have a statistically direct effect on Habit and these findings confirm the finding by Khatimah, et al. (2019). Conversely, other direct effects of Behavioral Intention due to Hedonic Motivation and Social influence are small and not statistically significant. The explanation behind this finding is on including Habit as an intervening variable on the relation of Hedonic Motivation on Behavioral Intention and Social Influence on Behavioral Intention as confirmed by Khatimah, et al. (2019). The decision regarding proposed hypotheses with the direct effect on Behavioral Intention in the theoretical model was presented in Table 16.

**Table 16. Decisions for research hypotheses**

Research Hypotheses	Reference
<b>Supported</b>	
H2: Hedonic Motivation has a statistically direct effect on Habit.	Khatimah (2019)[14]
H3: Habit has a statistically direct effect on Behavioral Intention to use online entertainment.	Khatimah (2019)[14], Chopdar (2018)[15], and Venkatesh (2012)[3]
H5: Social Influence has a statistically direct effect on Habit.	Khatimah (2019)[14]
H6: Price Value has a statistically direct effect on Behavioral Intention to use online entertainment.	Chopdar (2018), Alalwan (2018), Alalwan (2017), Alshare and Mousa (2014), and Venkatesh (2012)
<b>Partially Supported</b>	
H1: Hedonic Motivation has a statistically direct effect on Behavioral Intention to use online entertainment.	Harnadi (2017)[4], Koo (2009)[20], and Lee (2009)[10]
H4: Social Influence has a statistically direct effect on Behavioral Intention to use online entertainment.	Wang & Sun (2016)[7], Fan et al. (2012)[9], Venkatesh (2012)[3], Koo (2009)[20], and Lee (2009)[10]

### 6.3 Moderating Effect analysis

Table 17 displays decisions regarding moderating effect analysis of Gender, Age, Power Distance, Individualism, Feminism, and Uncertainty Avoidance derived from Table 13 and 15.

**Table 17. Decisions for moderating effect analysis**

Research Hypotheses	Comment	
Gender as a moderating effect	Effect for Males	Effect for Females
Gender has a significant moderating effect on the direct effect of	Medium, Positive,	Large, Positive,

<b>Research Hypotheses</b>	<b>Comment</b>	
Hedonic Motivation on Habit	Statistically significant	Statistically significant
Gender has not a significant moderating effect on the direct effect of Social Influence on Habit	Medium, Positive, Statistically significant	Medium, Positive, Not Statistically significant
Gender has a significant moderating effect on the direct effect of Habit on Behavioral Intention	Large, Positive, Statistically significant	Large, Positive, Statistically significant
Gender has not a significant moderating effect on the direct effect of Hedonic Motivation on Behavioral Intention	Small, Positive, Not Statistically significant	Small, Negative, Not Statistically significant
Gender has not a significant moderating effect on the direct effect of Price Value on Behavioral Intention	Medium, Positive, Statistically significant	Medium, Positive, Statistically significant
Gender has not a significant moderating effect on the direct effect of Social influence on Behavioral Intention	Small, Positive, Not Statistically significant	Small, Positive, Not Statistically significant
<b>Age as a moderating effect</b>	<b>Effect for Z Generation</b>	<b>Effect for Y Generation</b>
Age has not a significant a moderating effect on the direct effect of Hedonic Motivation on Habit	Medium, Positive, Statistically significant	Medium, Positive, Statistically significant
Age has not a significant a moderating effect on the direct effect of Social Influence on Habit	Medium, Positive, Statistically significant	Medium, Positive, Not Statistically significant
Age has a significant a moderating effect on the direct effect of Habit on Behavioral Intention	Large, Positive, Statistically significant	Large, Positive, Statistically significant
Age has not a significant a moderating effect on the direct effect of Hedonic Motivation on Behavioral Intention	Small, Positive, Not Statistically significant	Small, Positive, Not Statistically significant
Age has not a significant a moderating effect on the direct effect of Price Value on Behavioral Intention	Medium, Positive, Statistically significant	Medium, Positive, Not Statistically significant
Age has not a significant a moderating effect on the direct effect of Social influence on Behavioral Intention	Small, Positive, Not Statistically significant	Medium, Positive, Not Statistically significant
<b>Power Distance as a moderating effect</b>	<b>Effect for Higher PD</b>	<b>Effect for Lower PD</b>
Power Distance has not a significant moderating effect on the direct effect of Hedonic Motivation on Habit	Medium, Positive, Statistically significant	Medium, Positive, Statistically significant
Power Distance has not a significant moderating effect on the direct effect of Social Influence on Habit	Medium, Positive, Statistically significant	Medium, Positive, Statistically significant
Power Distance has not a significant moderating effect on the direct effect of Habit on Behavioral Intention	Large, Positive, Statistically significant	Large, Positive, Statistically significant
Power Distance has not a significant moderating effect on the direct effect of Hedonic Motivation on Behavioral Intention	Small, Positive, Not Statistically significant	Small, Positive, Not Statistically significant
Power Distance has not a significant moderating effect on the direct effect of Price Value on Behavioral Intention	Medium, Positive, Statistically significant	Medium, Positive, Statistically significant
Power Distance has not a significant moderating effect on the direct effect of Social influence on Behavioral Intention	Small, Positive, Not Statistically significant	Medium, Positive, Not Statistically significant
<b>Individualism-Collectivism as a moderating effect</b>	<b>Effect for Individualism</b>	<b>Effect for Collectivism</b>
Individualism-Collectivism has not a significant moderating effect on the direct effect of Hedonic Motivation on Habit	Medium, Positive, Statistically significant	Medium, Positive, Statistically significant
Individualism-Collectivism has not a significant moderating effect on the direct effect of Social Influence on Habit	Small, Positive, Not Statistically significant	Medium, Positive, Statistically significant
Individualism-Collectivism has not a significant moderating effect on the direct effect of Habit on Behavioral Intention	Medium, Positive, Statistically significant	Large, Positive, Statistically significant
Individualism-Collectivism has a significant moderating effect on the direct effect of Hedonic Motivation on Behavioral Intention	Medium, Positive, Not Statistically significant	Small, Negative, Not Statistically significant
Individualism-Collectivism has not a significant moderating effect on the direct effect of Price Value on Behavioral Intention	Medium, Positive, Not Statistically significant	Medium, Positive, Statistically significant
Individualism-Collectivism has not a significant moderating effect on the direct effect of Social influence on Behavioral Intention	Small, Positive, Not Statistically significant	Small, Positive, Not Statistically significant
<b>Feminisms-Masculinity as a moderating effect</b>	<b>Effect for Feminisms</b>	<b>Effect for Masculinity</b>
Feminisms-Masculinity has not a significant moderating effect	Large, Positive,	Medium, Positive,

Research Hypotheses	Comment	
on the direct effect of Hedonic Motivation on Habit	Statistically significant	Statistically significant
Feminisms-Masculinity has not a significant moderating effect on the direct effect of Social Influence on Habit	Small, Positive, Not Statistically significant	Medium, Positive, Statistically significant
Feminisms-Masculinity has a significant moderating effect on the direct effect of Habit on Behavioral Intention	Medium, Positive, Not Statistically significant	Large, Positive, Statistically significant
Feminisms-Masculinity has not a significant moderating effect on the direct effect of Hedonic Motivation on Behavioral Intention	Medium, Positive, Not Statistically significant	Small, Positive, Not Statistically significant
Feminisms-Masculinity has not a significant moderating effect on the direct effect of Price Value on Behavioral Intention	Medium, Positive, Not Statistically significant	Medium, Positive, Statistically significant
Feminisms-Masculinity has not a significant moderating effect on the direct effect of Social influence on Behavioral Intention	Medium, Positive, Not Statistically significant	Small, Positive, Not Statistically significant
<b>Uncertainty Avoidance (UA)</b>	<b>Effect for Lower UA</b>	<b>Effect for higher UA</b>
Uncertainty Avoidance has a significant moderating effect on the direct effect of Hedonic Motivation on Habit	Small, Positive, Not Statistically significant	Medium, Positive, Statistically significant
Uncertainty Avoidance has not a significant moderating effect on the direct effect of Social Influence on Habit	Large, Positive, Not Statistically significant	Medium, Positive, Statistically significant
Uncertainty Avoidance has not a significant moderating effect on the direct effect of Habit on Behavioral Intention	Medium, Positive, Not Statistically significant	Large, Positive, Statistically significant
Uncertainty Avoidance has not a significant moderating effect on the direct effect of Hedonic Motivation on Behavioral Intention	Medium, Positive, Not Statistically significant	Small, Positive, Not Statistically significant
Uncertainty Avoidance has not a significant moderating effect on the direct effect of Price Value on Behavioral Intention	Medium, Positive, Not Statistically significant	Medium, Positive, Statistically significant
Uncertainty Avoidance has not a significant moderating effect on the direct effect of Social influence on Behavioral Intention	Small, Positive, Not Statistically significant	Small, Positive, Not Statistically significant

From Table 17, it was concluded that:

1. For Gender: The moderating effect of Gender exists on the direct causal effect of Hedonic Motivation on Habit and Habit on Behavioral Intention.
2. For Age: The moderating effect of Age only exists on the direct causal effect of Habit on Behavioral Intention.
3. For Power Distance: The moderating effect of Power Distance did not exist on all causal effects in the Theoretical model.
4. For Individualism-Collectivism: The moderating effect of Individualism-Collectivism only exists on the direct causal effect of Hedonic Motivation on Behavioral Intention.
5. For Feminisms-Masculinity: The moderating effect of Feminisms-Masculinity only exists on the direct causal effect of Habit on Behavioral Intention.
6. For Uncertainty Avoidance: The moderating effect of Uncertainty Avoidance only exists on the direct causal effect of Hedonic Motivation on Habit.

### New Findings

The findings regard causal effect analysis with support and partially support the hypotheses derived from the previous research as displayed in Table 16 are not new findings. The new findings of the research come from the findings on moderating effect analysis including the satisfactory fit statistic not reported in previous research. Table 18 emphasizes the new findings related to the moderating effect of Gender, Age, Power Distance, Individualism, Feminism, and Uncertainty Avoidance.

**Table 18. New findings related to the moderating effects of Gender, Age, Power Distance, Individualism, Feminism, and Uncertainty Avoidance**

Moderating effects of Gender, Age, Power Distance, Individualism, Feminism, and Uncertainty Avoidance
<b>Gender</b>
a) <i>Gender has a significant moderating effect on the direct effect of Hedonic Motivation on Habit.</i>
<ul style="list-style-type: none"> <li>• <i>For males the effect of Hedonic Motivation on Habit is medium, positive, and statistically significant and for females the effect is large, positive, and statistically significant</i></li> </ul>

<b>Moderating effects of Gender, Age, Power Distance, Individualism, Feminism, and Uncertainty Avoidance</b>	
b)	<i>Gender has a significant moderating effect on the direct effect of Habit on Behavioral Intention.</i> <ul style="list-style-type: none"> <li>For males and females the effect of Habit on Behavioral Intention is large, positive, and statistically significant.</li> </ul>
c)	Gender does not have a significant moderating effect on the direct effect of Social Influence on Habit and Hedonic Motivation, Price Value, and Social Influence on Behavioral Intention. <ul style="list-style-type: none"> <li>For males the effect of Social Influence on Habit is medium, positive, and statistically significant but for females the effect is medium, positive, and not statistically significant.</li> <li>For males the effect of Hedonic Motivation on Behavioral Intention is small, positive, and not statistically significant and for females the effect is small, negative, and not statistically significant.</li> <li>For males and females the effect of Price Value on Behavioral Intention is medium, positive, and statistically significant.</li> <li>For males and females the effect of Social Influence on Behavioral Intention is small, positive, and not statistically significant.</li> </ul>
<b>Age</b>	
d)	<i>Age has a significant moderating effect on the direct effect of Habit on Behavioral Intention.</i> <ul style="list-style-type: none"> <li>For the Y and Z generations the effect of Habit on Behavioral Intention is large, positive, and statistically significant.</li> </ul>
e)	Age does not have a significant moderating effect on the direct effect of Hedonic Motivation or Social Influence on Habit and Hedonic Motivation, Price Value, or Social Influence on Behavioral Intention. <ul style="list-style-type: none"> <li>For Z and Y generations the effect of Hedonic Motivation on Habit is medium, positive, and statistically significant.</li> <li>For Z generation the effect of Social Influence on Habit and Price Value on Behavioral Intention is medium, positive, and statistically significant but for Y generation the effect is medium, positive, and not statistically significant.</li> <li>For Z and Y generations the effect of Hedonic Motivation or Social Influence on Behavioral Intention is small, positive, and not statistically significant.</li> </ul>
<b>Power Distance</b>	
f)	Power Distance does not have a significant moderating effect on the entire causal effect on the theoretical model. <ul style="list-style-type: none"> <li>For higher and lower Power Distance the effect of Hedonic Motivation or Social Influence on Habit and Price Value on Behavioral Intention is medium, positive, and statistically significant.</li> <li>For higher and lower Power Distance the effect of Hedonic Motivation or Social Influence on Behavioral Intention is small, positive, and not statistically significant.</li> <li>For higher and lower Power Distance the effect of Habit on Behavioral Intention is large, positive, and statistically significant.</li> </ul>
<b>Individualism-Collectivism</b>	
g)	<i>Individualism-Collectivism has a significant moderating effect on the direct effect of Hedonic Motivation on Behavioral Intention.</i> For Individualism the effect of Hedonic Motivation on Behavioral Intention is medium, positive, and not statistically significant and for Collectivism the effect is small, negative, and not statistically significant.
h)	Individualism-Collectivism does not have a significant moderating effect on the direct effect of Hedonic Motivation or Social Influence on Habit and Habit, Price Value, or Social Influence on Behavioral Intention. <ul style="list-style-type: none"> <li>For Individualism and Collectivism the effect of Hedonic Motivation on Habit and Habit on Behavioral Intention is medium, positive, and statistically significant.</li> <li>For Individualism the effect of Social Influence on Habit is small, positive, and not statistically significant but for Collectivism the effect is medium, positive, and statistically significant.</li> <li>For Individualism the effect of Hedonic Motivation on Behavioral Intention is medium, positive, and not statistically significant and for Collectivism the effect is small, negative, and not statistically significant.</li> <li>For Individualism the effect of Price Value on Behavioral Intention is medium, positive, and not statistically significant but for Collectivism the effect is medium, positive, and statistically significant.</li> <li>For Individualism and Collectivism the effect of Social Influence on Behavioral Intention is small, positive, and not statistically significant.</li> </ul>
<b>Feminisms-Masculinity</b>	



<b>Moderating effects of Gender, Age, Power Distance, Individualism, Feminism, and Uncertainty Avoidance</b>	
i)	<b><i>Feminisms-Masculinity has a significant moderating effect on the direct effect of Habit on Behavioral Intention.</i></b> For Feminisms the effect of Habit on Behavioral Intention is medium, positive, and not statistically significant and <b><i>for Masculinity the effect is large, positive, and statistically significant.</i></b>
j)	Feminisms-Masculinity does not have a significant moderating effect on the direct effect of Hedonic Motivation or Social Influence on Habit and Hedonic Motivation, Price Value, or Social Influence on Behavioral Intention. <ul style="list-style-type: none"> <li>• For Feminisms the effect of Hedonic Motivation on Habit is large, positive, and statistically significant and for Masculinity the effect is medium, positive, and statistically significant.</li> <li>• For Feminisms the effect of Social Influence on Habit is small, positive, and not statistically significant but for Masculinity the effect is medium, positive, and statistically significant.</li> <li>• For Feminisms the effect of Hedonic Motivation or Social Influence on Behavioral Intention is medium, positive, and not statistically significant and for Masculinity the effect is small, positive, and not statistically significant.</li> <li>• For Feminisms the effect of Price Value on Behavioral Intention is medium, positive, and not statistically significant but for Masculinity the effect is medium, positive, and statistically significant.</li> </ul>
<b>Uncertainty Avoidance</b>	
k)	<b><i>Uncertainty Avoidance has a significant moderating effect on the direct effect of Hedonic Motivation on Habit.</i></b> For lower Uncertainty Avoidances the effect of Hedonic Motivation on Habit is small, positive, and not statistically significant but <b><i>for higher Uncertainty Avoidances the effect is medium, positive, and statistically significant.</i></b>
l)	Uncertainty Avoidance does not have a significant moderating effect on the direct effect of Social Influence on Habit and Habit, Hedonic Motivation, Price Value, or Social Influence on Behavioral Intention. <ul style="list-style-type: none"> <li>• For lower Uncertainty Avoidances the effect of Social Influence on Habit is large, positive, and not statistically significant but for higher Uncertainty Avoidances the effect is medium, positive, and statistically significant.</li> <li>• For lower Uncertainty Avoidances the effect of Habit on Behavioral Intention is medium, positive, and not statistically significant but for higher Uncertainty Avoidances the effect is large, positive, and statistically significant.</li> <li>• For lower Uncertainty Avoidances the effect of Hedonic Motivation on Behavioral Intention is medium, positive, and not statistically significant and for higher Uncertainty Avoidances the effect is small, positive, and not statistically significant.</li> <li>• For lower Uncertainty Avoidances the effect of Price Value on Behavioral Intention is medium, positive, and not statistically significant but for higher Uncertainty Avoidances the effect is medium, positive, and statistically significant.</li> <li>• For lower and higher Uncertainty Avoidances the effect of Social Influence on Behavioral Intention is small, positive, and not statistically significant.</li> </ul>

#### 6.4 Implications

This research confirms the findings contributing to the current literature. Firstly, the previous literature on acceptance of e-money focuses on Habit as a mediator on the acceptance (Khatimah et al., 2019). The literature examines the effect of Hedonic Motivation and Social Influence on Habit and afterward on Behavioral Intention. The other literature (Baabdullah et al., 2019; Chopdar et al., 2018; Venkatesh et al., 2012) proposes Hedonic Motivation, Habit, and Price Value to have a significant direct effect on Behavioral Intention. Our research proposed and tested the mediator effect of Habit on acceptance of online entertainment. We also add Hedonic Motivation and Social Influence to have a direct effect on Habit and Price value to have a direct effect on Behavioral Intention. This research contributes to the existing literature on online entertainment concerning Habit as a mediator have a direct effect on Behavioral Intention and integrating Price Value as a factor to have a direct effect on Behavioral Intention. Our empirical findings seem congruent with the study conducted by Khatimah et al. (2019) that states Hedonic Motivation and Social Influence have a direct effect on Habit and Habit on Behavioral Intention. The finding also seems congruent with the study conducted by Baabdullah et al. (2019), Chopdar et al. (2018), and Venkatesh et al. (2012). The interesting findings also enhance the comprehension of theory application in the online entertainment context.

Secondly, the moderating effect of Age and Gender on previous literature come from studies on online gaming and acceptance of technology in general (Harnadi, 2017; Akbar, 2013; Venkatesh et al., 2012; Lee, 2009; Wang and Wang, 2008; Venkatesh et al., 2003). The moderating effect of cultural factors on previous literature in the e-learning and mobile payment device context comes from Tarhini et al. (2016) and Alshare and Mousa (2014). This research reveals that in the acceptance of online entertainment context, the effect of Hedonic Motivation on Habit is greater on females than males and the effect of Habit on Behavioral Intention is equal for males and females. Subsequently, the effect of Habit on Behavioral Intention is equal for the Z and Y generation. Furthermore, the findings on cultural factors as a moderating effect reveal that Individualism-Collectivism has a significant moderating effect on the direct effect of Hedonic Motivation on Behavioral Intention. Moreover, the effect of Habit on Behavioral Intention is only on Masculinity and not on Feminisms. Finally, the effect of Hedonic Motivation on Habit is only on higher Uncertainty Avoidances and not on lower Uncertainty Avoidances.

This research proposes practical implications for practitioners, educators, parents, and online application developer for entertainment. Practitioners need to improve the effectiveness of their methods for online ads embedded in an application. Seemingly, the effectiveness methods must consider the consumers of the application. The findings of research offer the segmentation and targeting insight regarding the different ages, gender, and culture of the consumers. Moreover, educators and parents need to know the characteristics of consumers of the applications. Their student and children are the consumers of the application. The information provided by this research can be used as a guide to know their level of passion and practice in using the application. Eventually, this research can serve the application developers the insight on how to design the applications to fulfill the consumers of different ages, genders, and cultures and their perceptions in using the application.

### 6.5 Limitations and future work

First of all, this research on the role of age, gender, and cultural factors as moderators on the acceptance of online entertainment appears to be the first conducted in the context of Indonesia. Therefore, there is a limitation on its external validity so that future work is recommended to repeat. Second, the generalizability of the research findings should be reviewed. Future works must consider different groups related to ages to repeating the test of the research. The expansion of the theoretical model is possible to future work by introducing other constructs such as Perceived Usefulness and Perceived Ease of Use as offered in the Technology Acceptance Model (TAM) by Davis (1989). Third, we employed Hofstede's cultural dimensions by Straub (1997) to test their effect on the acceptance of online entertainment. The future work may replace or expand the dimension with other cultural factors from other literature.

## 7. Conclusions

The result of the research encloses findings confirming the previous studies which state that people tend to perform behaviors automatically in using online media entertainment depends on their perception that using it is fun and the importance other people believe that they should use it. Furthermore, the nature of the user of online entertainment in using online entertainment in the future is affected by the important other's belief that they should use it and their perception that using it is fun. The new findings of this research relating to moderation effect analysis confirm that age, gender, and cultural factors have a role in the acceptance of online entertainment. However, the effect of Hedonic Motivation on Habit was important for: females than males; and higher Uncertainty Avoidances but not lower Uncertainty Avoidances. Furthermore, the effect of Habit on Behavioral Intention was also important for: both males and females; both Z and Y generations; and Masculinity but not for Feminisms. The other findings concern the usage rates for online entertainment in Table 11, almost all of the respondents (80 percent) use for every day in a week with almost half of these using up to 15 hours per week. Based on these findings, parents and teachers may give guidance to online entertainment lovers to manage their time better for study and take pleasure.

### Acknowledgment

The authors gratefully acknowledge the Directorate General of Higher Education, Ministry of Education and Culture, Republic of Indonesia, which provide research project including the support from the Department of Information Systems, Soegijapranata Catholic University, Indonesia.

### Notes

- [1] Kemp, S. "Special Reports, Digital Use Around the World in July 2020," *wearesocial.com*, July. 21, 2020. retrieved from <https://wearesocial.com/blog/2020/07/digital-use-around-the-world-in-july-2020>. [Accessed: Nov. 13, 2020].
- [2] Hootsuite & We Are Social, "Digital 2020: Indonesia," *datareportal.com*, February. 18, 2020, retrieved from <https://datareportal.com/reports/digital-2020-indonesia>. [Accessed: Nov. 13, 2020].

## References

### References

- Akbar, F., (2013), "What affects students' acceptance and use of technology?" Theses Report, Dietrich College of Humanities and Social Sciences.
- Alalwan, A. A., Dwivedi, Y. K., Rana, N. P., Algharabat, R., (2018), "Examining factors influencing Jordanian customers' intentions and adoption of internet banking: Extending UTAUT2 with risk," *Journal of Retailing and Consumer Services*, Vol. 40, pp.125-138.
- Alshare, K. A., and Mousa, A. A., (2014), "The Moderating Effect of Espoused Cultural Dimensions on Consumer's Intention to Use Mobile Payment Devices," *Thirty Fifth International Conference on Information Systems*, Auckland, pp. 1-15.
- Baabdullah, A. M., Alalwan, A. A., Rana, N. P., Kizgin, H., and Patil, P., (2019), "Consumer use of mobile banking (M-Banking) in Saudi Arabia: Towards an integrated model," *International Journal of Information Management*, Vol. 44, pp. 38-52.
- Chen, C.-P., (2018), "Understanding mobile English-learning gaming adopters in the self-learning market: The Uses and Gratification Expectancy Model," *Computers & Education*, Vol. 126, pp 217-230.
- Cohen, J., (1988), *Statistical power analysis for the behavioral sciences* (2nd ed.), Academic Press, New York, NY.
- Chawla, D. and Joshi, H. (2020), "The moderating role of gender and age in the adoption of mobile wallet", *Foresight*, Vol. 22 No. 4, pp. 483-504.
- Chopdar, P. K., Korfiatis, N., Sivakumar, VJ., and Lytras M. D., (2018), "Mobile shopping apps adoption and perceived risks: A cross-country perspective utilizing the Unified Theory of Acceptance and Use of Technology," *Computers in Human Behaviour*, Vol. 86, pp. 109-128.
- Davis, F. D. (1989). "Perceived Usefulness, Perceived Ease of Use, and User Acceptance of Information Technology," *Management Information Systems Quarterly*, Vol. 13 No. 3, pp. 319-340.
- Fan, L., Ghu, C. G., Suh, Y. H., & Lee, S. C., (2012), "How to attract Chinese online game users," *Asian Journal on Quality*, Vol. 13 No. 1, 7-27.
- Harnadi, B., (2017), "An investigation of the adoption of online game technologies in Indonesia," *International Journal of Gaming and Computer-Mediated Simulations*, Vol.9 No. 1, pp. 1-27.
- Khatimah, H., Susanto, P., and Abdullah, N. L., (2019), "Hedonic Motivation and Social Influence on Behavioral Intention of E-Money: The Role of Payment Habit as a Mediator," *International Journal of Entrepreneurship*, Vol. 23 No. 1, pp. 1-9.
- Kline, R. B., (2005), *Principles and Practice of Structural Equation Modeling*, Guilford Press, London.
- Koo, D. M., (2009), "The moderating role of locus of control on the links between experiential motives and intention to play online games. *Computers in Human Behavior*, Vol. 25 No. 2, pp. 466-474.
- Lee, M. C., (2009), "Understanding the Behavioural Intention to Play Online Games," *Online Information Review*, Vol. 33 No. 5, pp. 849-872.
- Luo, M.M., Chea, S., and Chen, J.-S., (2011), "Web-based information service adoption: A comparison of the motivational model and the uses and gratifications theory," *Decision Support Systems*, Vol. 51, pp. 21-30.
- Merhi, M., Hone, K., Tarhini, A. and Ameen, N. (2020), "An empirical examination of the moderating role of age and gender in consumer mobile banking use: a cross-national, quantitative study", *Journal of Enterprise Information Management*, Vol. ahead-of-print No. ahead-of-print.
- Merikivi, J., Tuunainen V. & Duyen, N., (2017), "What Makes Continued Mobile Gaming Enjoyable?" *Computers in Human Behavior*, Vol. 68, pp. 411-421.
- Šorgo, A., Bartol, T., Dolničar, D. and Boh Podgornik, B. (2017), Attributes of digital natives as predictors of information literacy in higher education. *Br J Educ Technol*, Vol. 48, pp. 749-767.
- Straub, D., Keil, M., and Brenner, W., (1997), "Testing the technology acceptance model across cultures: A three country study," *Information and Management*, Vol. 33, pp. 1 - 11.
- Tarhini, A., Hone, K., Liu, X., and Tarhini, T., (2017), "Examining the moderating effect of individual level cultural values on users' acceptance of Elearning in developing countries: a structural equation modeling of an extended technology acceptance model," *Interactive Learning Environments*, Vol. 25 No. 3, pp. 306-328.
- Venkatesh, V., Morris, M. G., Davis, G. B., and Davis, F. D., (2003), "User acceptance of information technology: toward a Unified View," *MIS Quarterly*, Vol. 27, No. 3, pp. 425-479.
- Venkatesh, V., Thong, J. Y. L., & Xu, X., (2012), "Extending the Unified Theory of Acceptance and Use of Technology", *MIS Quarterly*, Vol. 36 No. 1, pp. 157-178.
- Wang, Q. and Sun, X., (2016), "Investigating gameplay intention of the elderly using an Extended Technology Acceptance Model (ETAM)," *Technological Forecasting & Social Change*, Vol. 107, pp. 59-68.
- Wei, P. S., & Lu, H. P., (2014), "Why do people play mobile social games? An examination of network externalities and of uses and gratifications," *Internet Research*, Vol. 24 No. 3, pp. 313-33.
- Wang, H. Y., & Wang, Y. S., (2008) "Gender differences in the perception and acceptance of online games," *British Journal of Educational Technology*, Vol. 39 No. 5, pp. 787-806.

## Appendix

### Questionnaire

#### A. Latent Variables

##### Hedonic Motivation

- While playing online entertainment, I feel happy.
- I feel that playing online entertainment makes me relax.
- Playing online entertainment, keep me entertained.

##### Price Value

- In my opinion, the price of using online entertainment is still reasonable.
- The benefits of using online entertainment are equivalent to the money I have spent.

- 1  
2  
3 • With the price incurred, the use of online entertainment still benefits me.

4 Social Influence

- 5 • People who are influential to me, think that it is not a problem for them if I play entertainment online.  
6 • People who are important to me think that it is not a problem for them if I play online entertainment media.  
7 • People whom I respect for their opinions suggest that I keep playing the online entertainment media.

8 Habit

- 9 • Playing online entertainment has become a habit for me.  
10 • I have to play online entertainment.  
11 • I feel addicted to online entertainment.

12 Behavioral Intention

- 13 • I intend to continue playing online entertainment in the future.  
14 • I predict that I will continue to play online entertainment.  
15 • I plan to continue playing online entertainment.

16  
17 B. Cultural Variables

18 Power Distance

- 19 • Teachers/Lecturers must make most decisions without consulting students.  
20 • Teachers/Lecturers should not ask students' opinions too often.  
21 • Students must agree with the decisions made by the Teacher/Lecturer and the school/university  
22 management.

23 Individualism

- 24 • It is better to study/work in groups than alone.  
25 • Group success is more important than individual success.  
26 • Awards for individuals are less important than rewards for groups.

27 Feminisms

- 28 • It is important for me to appreciate outstanding academic achievements.  
29 • It is important for me to focus more on achieving superior academic achievements.  
30 • It's important for me to outperform my classmates.

31 Uncertainty Avoidance

- 32 • Rules and regulations are important because they tell students what to expect from the school/university.  
33 • It's important to know the specific requirements and instructions spelled out in detail so I always know  
34 what to do.  
35 • Standardized operational work instructions and procedures are very helpful for my learning.
- 36  
37  
38  
39  
40  
41  
42  
43  
44  
45  
46  
47  
48  
49  
50  
51  
52  
53  
54  
55  
56  
57  
58  
59  
60

[# Home](#)[Author](#)[Review](#)

Please click the "Return to Dashboard" button below to view your submitted manuscript OR click the link "Log Out" at the upper right side of the screen to log out of your account.

# Submission Confirmation

[Print](#)

Thank you for your submission

**Submitted to**

Online Information Review

**Manuscript ID**

OIR-12-2020-0543

**Title**

An Investigation of the Acceptance of Online Entertainment Technologies in Indonesia

**Authors**

Harnadi, Bernardinus

Widiantoro, Albertus

Prasetya, FX Hendra

Sanjaya, Ridwan

**Date Submitted**

08-Dec-2020

[Author Dashboard](#)

---

© Clarivate Analytics | © ScholarOne, Inc., 2020. All Rights Reserved.

ScholarOne Manuscripts and ScholarOne are registered trademarks of ScholarOne, Inc.

ScholarOne Manuscripts Patents #7,257,767 and #7,263,655.

[@ScholarOneNews](#) | [System Requirements](#) | [Privacy Statement](#) | [Terms of Use](#)

Dokumen pendukung luaran Tambahan #3

Luaran dijanjikan: Prosiding dalam pertemuan ilmiah Nasional

Target: sudah terbit/sudah dilaksanakan

Dicapai: Submitted

Dokumen wajib diunggah:

1.

Dokumen sudah diunggah:

1. Naskah artikel

Dokumen belum diunggah:

-

Peran penulis: co-author

Nama Konferensi/Seminar: 2021 3rd EAST INDONESIA CONFERENCE ON  
COMPUTER AND INFORMATION TECHNOLOGY (EIconCIT)

Lembaga penyelenggara: Institut Sains & Teknologi Terpadu Surabaya, Indonesia

Tempat penyelenggara: Surabaya

Tgl penyelenggaraan mulai: 9 April 2021 | Tgl selesai: 11 April 2021

Lembaga pengindeks: IEEE Xplore

URL website: <https://eiconcit.org/>

Judul artikel: Examining the Adoption of Mobile Payment Service: Expectation  
Confirmation Model with Trust

# Examining the Adoption of Mobile Payment Service: Expectation Confirmation Model with Trust

Albertus Dwiyoga Widiyanto.  
Department Information System  
Faculty Computer Science  
Soegijapranata Catholic University  
Semarang, Indonesia  
email: yoga@unika.ac.id

FX Hendra Prasetya  
Department Information System  
Faculty Computer Science  
Soegijapranata Catholic University  
Semarang, Indonesia  
email: hendra@unika.ac.id

Bernardinus Harnadi  
Department Information System  
Faculty Computer Science  
Soegijapranata Catholic University  
Semarang, Indonesia  
email: bharnadi@unika.ac.id

*Abstract*— This study has a purpose to examine the acceptance of mobile payment services by employing a modified ECM model with Trust. Several related studies on e-commerce and mobile payment have been investigated to derive important variables which can be employed on a proposed model. The model expresses the effect of customers' trust on their satisfaction in using mobile payment services and their continuance intention in using it. The online questionnaires constructed based on the proposed model were distributed to mobile payment users to gather their perceptions in using it. The 338 questionnaires gathered were analyzed statistically by SEM to test the hypotheses of the study. The results of the analysis reveal that customers' trust is an important variable to enhance customers' satisfaction and continuance intention in using mobile payment services. Other results indicate that Trust and Confirmation have a direct effect on the Perceived Usefulness of the services. Furthermore, both Perceived Usefulness and Trust will make consumers feel satisfied and tend to continuance their intention in using mobile payment services. This study contributes to financial service providers in delivering an obviousness, how was the trust of services can make consumers feel satisfy and use the service continually.

Keywords—ECM, Trust, mobile payment, SEM, Continuance Intention

## I. INTRODUCTION

Mobile Payment is a non-cash payment instrument using a cellular phone (Smartphone) as a device. Mobile payment methods use various media, such as NFC, QR Code, OTP (One Time Password).

Mobile payment (MP) is currently often used to make payments in various types of transactions. In Indonesia, there are many mobile payments which are divided into three categories, players from telecommunication companies are Dompetku, T-Cash, FlexiCash, Cash by XL. From banking companies, there are Mandiri e-Cash, Rekening Ponsel, Mega Virtual, BBM Money, Sakuku by BCA. From other backgrounds (technology startups) there are Go-Pay, Ovo, DANA, Doku, PayPro, and PayAcces.

Indonesia according to the Global Payment Report is the largest market in Southeast Asia. Indonesia is the fourth most populous country globally and contains the largest regional middle class. Financial Technology is in second place with a 25% market share.

In Indonesia, transactions using mobile payments have experienced significant growth. Mobile payment innovation has become an important part of his life. The mobile payment system has been used by many people in urban areas. This will certainly affect their daily life.

Although mobile payment has seen its growth, this study will dig deeper about the sustainability of using mobile payment technology.

From this study, we can find the post-adoption behavior of transactions in fulfilling daily needs in the context of mobile payments, which involve trusts. which may hinder the continued use of the user. Therefore, it is necessary to conduct empirical research to identify the factors that influence the continued use of mobile payments.

The expectation confirmation model (ECM) believes that users' intentions to use specific information systems and services are positively determined by their overall satisfaction in using the systems and services. Concerning smart services and products, the relationship between user-perceived satisfaction and the intention to use services and products has been consistently handled (Park, 2020). User satisfaction is a highly socialized activity that is not only influenced by the perceived benefits themselves but is also influenced by organizational support [1].

A number of studies have investigated the relationship between trust and customer adoption behavior. In the context of digital payments and mobile banking, trust is very important because of the threat of privacy and security issues [2]. Trust in technology can encourage users to adopt IT, which leads to a situation where end users can learn and understand the use of IT [3].

Customers rely on online service providers for accurate and current information; demonstrated that providing higher quality information (i.e. information that is relevant, highly understandable, accurate, complete and timely) increases the level of trust.

## II. PROPOSED MODEL AND HYPOTHESIS

The model proposed in this study can be seen in Figure 1 below:

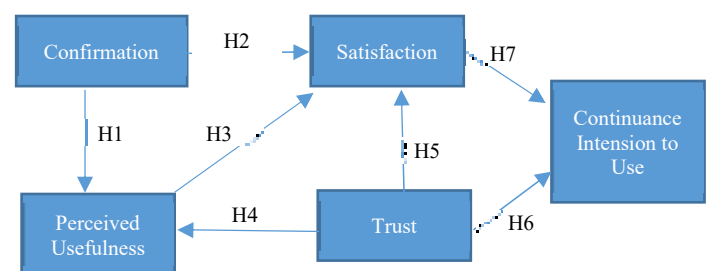

Fig. 1. The model used in this study



Continuance intention to use is Understanding continuous use or (as opposed to initial use or "acceptance"). This continues at the individual user level where individuals use the tool on a continuous basis. By using it can lead to the next life By using it continuously people will get an effective customer base, market share. The revenue of these companies depends on the number of initial users (new subscriptions) and the number of continuous users (subscription renewals)[4].

Trust refers to customers' beliefs about the integrity, policies and capabilities of service providers. Trust that increases customers' willingness to always use digital services for financial transactions [5].

Perceived usefulness is a core variable in TAM for explaining behavioral intentions. PU is defined as the extent to which a person believes that using a certain system will improve his job performance (Davis, 1989). The relationship between perceived benefits and satisfaction was studied by [6] in the context of mobile commerce and for the adoption of mobile banking by [7]. Empirical results prove that PU is one of the most important predictors of intention to use technology [8].

Consumer confirmation is comparing the performance level of a product or service with evaluative standards formed by expectations before their purchase, validating the decision to use [4]. People compare the expectations and performance before use, which is imagined as the actual performance expectation of M-wallet through various functions such as digital payments, secure information storage, the convenience of use, power efficiency, connectivity, integration with other relevant applications, operating system compatibility and usage rewards [9-10].

Satisfaction is a psychological concept of purchasing and using experiences [11]. The current study focuses on how users feel about all aspects of their experience, including the purchase experience and smart wearable.

#### A. Confirmation on Perceived Usefulness

Confirmation will increase the perception of usefulness while disconfirmation will reduce this perception [12]. In mobile instant research [13] said that confirmation has a positive effect on the perceived of usefulness. In the m-swallow adoption research conducted by [10] said that confirmation has a positive effect on perceived usefulness. So in this study applies confirmation of financial technology. Then the hypothesis made is:

**H1: Confirmation has a positive effect on Perceived Usefulness**

#### B. Confirmation on Satisfaction

Previous research has found that confirmation is positively related to satisfaction [4]. When the usage experience matches or exceeds initial expectations, there is a confirmation to lead to user satisfaction because of the expected benefits. In instant mobile research [13] said that confirmation has a positive effect on satisfaction. In the research on the adoption of m-swallow conducted by [10] said that confirmation has a positive effect on satisfaction. So in this study, this study applies confirmation of financial technology. Then the hypothesis made is:

**H2: Confirmation has a positive effect on Satisfaction**

#### C. Perceived Usefulness on Satisfaction

In ECM, post-consumption expectations are represented in terms of the perceived ex-post usability. Perceived usefulness is the user's perception of the expected benefits from using IS [14]. In the research on the adoption of m-swallow conducted by [10] said that Perceived usefulness has a positive effect on satisfaction, this research makes a hypothesis:

**H3: Perceived usefulness has a positive effect on Satisfaction.**

#### D. Trust on Perceived Usefulness

In marketplace research using Kaskus [15] reveals that trust is significantly perceived usefulness, which means that trust perceived usefulness can increase customer intention to buyback. Trust can increase consumer intention to buy back online. So in this study proposes the use of trust and perceived usefulness in the use of mobile payments. Then a hypothesis is proposed:

**H4: Trust has a positive effect on Perceived usefulness.**

#### E. Trust on Satisfaction and Continuance intention to use

When a user's satisfaction with smartphone banking increases, they will have a tendency to use the system again [4]. This level of satisfaction is influenced by the trust which is a consequence of post-adoption beliefs. Research [16] in e-banking revealed that Trust significantly influences user satisfaction and Trust significantly influences continuance use intention. Based on this the following hypothesis is made:

**H5: Trust has a positive effect on Satisfaction**

**H6: Trust has a positive effect on Continuance Intention to Use**

#### F. Satisfaction on Continuance intention to use

This study adopts the definition of satisfaction using mobile food apps proposed by [17] which defines customer satisfaction with respect to previous purchasing experiences with certain electronic commerce companies. "In line with this definition, the use of mobile apps matches or exceeds customer expectations, customers will more pleased with their experience related to the application of mobile apps. Thus, the following hypothesis proposes that:

**H6: Satisfaction has a positive effect on Continuance Intention to Use**

### III. METHODOLOGY

The methodology in this study uses statistical tests. The statistical test used is the SEM method and uses Smart PLS. In the SEM test, the first is to test the validity of the questionnaire data from 338 respondents. Data collection from respondents is done using google form. There are 2 stages in this validity test, namely the convergent validity test, namely by looking at the outer loading value, and the discriminant validity test by looking at the Fornell Lacker value. The data is said to be convergent valid if the outer loading value of each indicator is above 0.7 and it is said to be discriminately valid if the Fornell Lacker value between the same variables is the highest value.

After the data is declared valid by testing its validity, then the reliability test is carried out by looking at the Cronbach's Alpha value and its AVE value. The data is said to be reliable if the Cronbach's Alpha value is above 0.7 and the AVE value is above 0.5.

Hypothesis test is the last test conducted for SEM PLS, namely by looking at the P value, using a test level of 5%, meaning that if the P value is below 0.05, then the hypothesis is accepted, if the P value is above 0.05 then the hypothesis is rejected.

#### IV. DATA ANALYSIS AND DISCUSSION

##### A. Demographic of Respondents

Respondents used in this study were 338 people, with demographics can be seen in Table 1.

TABLE I. TABLE RESPONDENT DEMOGRAPHIC

Number of Respondents (n=338)		
<b>Long Time Using:</b>		
<= 6 months	18	5.33%
7 s/d 12 month	37	10.95%
>2,5 years	107	31.66%
1 s/d 1,5 years	1	0.30%
1,1 s/d 1,5 years	64	18.93%
1,6 s/d 2 years	75	22.19%
2,1 s/d 2,5 years	36	10.65%
<b>Income:</b>		
<= 3 million	127	37.57%
>11 million	41	12.13%
>9,1-11 million	1	0.30%
3,1-5 million	64	18.93%
5,1-7 million	60	17.75%
7,1-9 million	24	7.10%
9,1-11 million	21	6.21%
<b>Gender:</b>		
Female	147	43%
Male	191	57%
<b>Education:</b>		
Diploma	20	5.92%
Magister and Doctor	75	22.19%
Undergraduate	218	64.50%
<High School	25	7.40%
<b>Average Usage:</b>		
Several times a month	155	45.86%
Several times a day	15	4.44%
Several times a week	109	32.25%
Almost every day	59	17.46%

From Table 1, it can be seen that the duration of use is dominated by usage less than 2.5 years, namely as much as 31.66%. Meanwhile, the income of respondents is dominated by users who have an income of less than 3 million per month. For education level, it was dominated by respondents with undergraduate education as much as 64.50%. Meanwhile, the average usage is at most several times a month.

##### B. Validity Test

###### 1. Convergent validity

The convergence test of validity is by looking at the outer factor of the statistical test using Smart PLS as shown in Table 2.

TABLE II. OUTER LOADING FACTOR

CI1		0.906			
CI2		0.917			
CI3		0.870			
CI4		0.880			
COF1	0.801				
COF2	0.860				
COF3	0.901				
COF4	0.800				

PU1			0.893		
PU2			0.930		
PU3			0.829		
SAT1				0.909	
SAT2				0.915	
SAT3				0.934	
SAT4				0.893	
TRU1					0.867
TRU2					0.843
TRU3					0.855

From data Table 2, it can be seen that the value of the outer loading factor of all indicators is greater than 0.7, which means that the indicator is valid.

In addition to seeing outer loading, for convergence of this validity, the Average Variance Extracted (AVE) value must also be seen in Table 3.

TABLE III. AVE VALUE

Variable	Average Variance Extracted (AVE)
COF	0.708
CI	0.798
PU	0.783
SAT	0.833
TRU	0.731

Based on Table 3, the AVE value is above 0.5. By looking at the results from Table 2 and Table 3, it can be concluded that the data is convergent valid.

##### 2. Discriminant Validity

A discriminant validity test is carried out by looking at Fornell Lacker criteria as in Table 4.

TABLE IV. FORNELL-LARCKER CRITERION

	COF	CI	PU	SAT	TRU
COF	0.841				
CI	0.637	0.893			
PU	0.571	0.547	0.885		
SAT	0.751	0.730	0.582	0.913	
TRU	0.655	0.734	0.513	0.825	0.855

Based on Table 4, it can be seen that between the same variables, for example, COF and COF have the highest value compared to other variables. This proves that this model meets the requirements of discriminant validity.

##### C. Reliability Test

After the research model is declared valid data, the next step is to test the reliability. The reliability test was carried out by looking at the Cronbach Alpha value and also the composite reliability value as shown in Table 5.

TABLE V. THE VALUE CRONBACH'S ALPHA AND COMPOSITE RELIABILITY

Var	Cronbach's Alpha	Composite Reliability
COF	0.861	0.906
CI	0.916	0.941
PU	0.860	0.915
SAT	0.933	0.952
TRU	0.816	0.891

Table 5 shows that the values of Cronbach's Alpha and Composite reliability are both greater than 0.7 which means that the data in this model are reliable.

#### D. Hypothesis testing

The last step of this statistical test is to test the hypotheses that are made in the proposed model. Before being tested, the data was bootstraps 5000 times, so that the test results could be accounted for. This hypothesis test uses a two-tailed test with a p value of 5%, the results can be seen in Table 6.

TABLE VI. RESULT HYPOTHESIS TEST

	Original Sample (O)	Sample Mean (M)	T Statistics ( O/STDEV )	P Values	Hipotesa
COF -> PU	0.411	0.413	7,534	0.000	Accepted
COF -> SAT	0.323	0.324	7,542	0.000	Accepted
PU -> SAT	0.112	0.111	3,058	0.002	Accepted
SAT -> CI	0.388	0.388	5,961	0.000	Accepted
TRU -> CI	0.414	0.415	6,478	0.000	Accepted
TRU -> PU	0.244	0.244	4,406	0.000	Accepted
TRU -> SAT	0.556	0.556	13,392	0.000	Accepted

Based on table 6, the results of the hypothesis test show that the value of the P Value is below 5% or 0.05 for all Hypotheses, which means that all hypotheses compiled in the proposed research model are accepted.

As shown in Table VI, all hypotheses are supported. Table IV shows that all the hypotheses are accepted. The hypothesis in the hypothesis group is very strong with the original sample value (O) greater than 0.388 is satisfaction with Continuance Intention, Trust on Continuance Intention, Trust on Satisfaction, Confirmation on Perceived of Used. while the hypothesis in the moderate group with the original sample value (O) is greater than 0.112 is perceived of used to satisfaction, trust to perceived of used, confirmation of satisfaction.

#### CONCLUSION

This study aims to examine various factors that influence the sustainable adoption and use of mobile payments by Indonesian consumers. First, the researcher applies the expectation confirmation model (ECM) as the main theory and extends the model with the Trust construction to make it more relevant to consumers. Empirically test the ECM model among 338 respondents to identify a significant determinant of consumer usage behavior towards mobile payments.

The results reveal that the construction of trust is a significant determinant of the behavior of using mobile payments through Continuance Intention, Satisfaction, and Perceived of Use.

This research confirms that the mobile payment service provided is following what users expect. By using mobile payment, users can save time. Mobile Payment users believe and are satisfied with the service and users will continue to take advantage of the mobile payment service.

#### ACKNOWLEDGMENT

I would like to gratefully acknowledge the Directorate General of Higher Education, Ministry of Education and Culture, Republic of Indonesia, which provide research project including the support from Department of Information Systems, Soegijapranata Catholic University, Indonesia

#### REFERENCES

- [1] Wang, G., & Song, J. (2017). The relation of perceived benefits and organizational supports to user satisfaction with building information model (BIM). *Computers in Human Behavior*, 68, 493–500. <https://doi.org/10.1016/j.chb.2016.12.002>
- [2] Alkhowaiter, W. A. (2020). Digital payment and banking adoption research in Gulf countries: A systematic literature review. *International Journal of Information Management*, 53(February), 102102. <https://doi.org/10.1016/j.ijinfomgt.2020.102102>
- [3] Kabra, G., Ramesh, A., Akhtar, P., & Dash, M. K. (2017). Understanding behavioral intention to use information technology: Insights from humanitarian practitioners. *Telematics and Informatics*, 34(7), 1250–1261. <https://doi.org/10.1016/j.tele.2017.05.010>
- [4] Bhattacharjee, A. (2011). Understanding Information Systems Continuance: An Expectation-Confirmation Model. *MIS Quarterly*, 25(3), 351–370.
- [5] Gerrard, P., & Barton Cunningham, J. (2003). The diffusion of Internet banking among Singapore consumers. *International Journal of Bank Marketing*, 21(1), 16–28. <https://doi.org/10.1108/02652320310457776>
- [6] Agrebi, S., & Jallais, J. (2015). Explain the intention to use smartphones for mobile shopping. *Journal of Retailing and Consumer Services*, 22, 16–23. <https://doi.org/10.1016/j.jretconser.2014.09.003>
- [7] Bankole, F. O., Bankole, O. O., & Brown, I. (2011). Mobile Banking Adoption in Nigeria. *The Electronic Journal of Information Systems in Developing Countries*, 47(1), 1–23. <https://doi.org/10.1002/j.1681-4835.2011.tb00330.x>
- [8] Natarajan, T., Balasubramanian, S. A., & Kasilingam, D. L. (2017). Understanding the intention to use mobile shopping applications and its influence on price sensitivity. *Journal of Retailing and Consumer Services*, 37(January), 8–22. <https://doi.org/10.1016/j.jretconser.2017.02.010>
- [9] Susanto, A., Chang, Y., & Ha, Y. (2016). Determinants of continuance intention to use the smartphone banking services: An extension to the expectation-confirmation model. *Industrial Management and Data Systems*, 116(3), 508–525. <https://doi.org/10.1108/IMDS-05-2015-0195>
- [10] Gupta, A., Yousaf, A., & Mishra, A. (2020). How pre-adoption expectancies shape post-adoption continuance intentions: An extended expectation-confirmation model. *International Journal of Information Management*, 52(April 2019), 102094. <https://doi.org/10.1016/j.ijinfomgt.2020.102094>
- [11] Bhattacharjee, A., & Premkumar, G. (2012). Theoretical Model and Longitudinal Test Article in Belief and Changes Understanding Information Attitude Toward Technology A Theoretical Usage : Model and Longitudinal. *Management Information Systems*, 28(2), 229–254. <https://doi.org/10.2307/25148634>
- [12] Thong, J. Y. L., Hong, S. J., & Tam, K. Y. (2006). The effects of post-adoption beliefs on the expectation-confirmation model for information technology continuance. *International Journal of Human-Computer Studies*, 64(9), 799–810. <https://doi.org/10.1016/j.ijhcs.2006.05.001>
- [13] Oghuma, A. P., Libaque-Saenz, C. F., Wong, S. F., & Chang, Y. (2016). An expectation-confirmation model of continuance intention to use mobile instant messaging. *Telematics and Informatics*, 33(1), 34–47. <https://doi.org/10.1016/j.tele.2015.05.006>
- [14] Davis, F. D. (1989). Perceived usefulness, perceived ease of use, and user acceptance of information technology. *MIS Quarterly: Management Information Systems*, 13(3), 319–339. <https://doi.org/10.2307/249008>
- [15] Setyorini, R., & Nugraha, R. P. (2016). The Effect of Trust Towards Online Repurchase Intention With Perceived Usefulness As An

Intervening Variable : A Study on KASKUS Marketplace Customers.  
*The Asian Journal of Technology Management*, 9(1), 1–7.

- [16] Liébana-Cabanillas, F., Muñoz-Leiva, F., & Rejón-Guardia, F. (2013). The determinants of satisfaction with e-banking. *Industrial Management and Data Systems*, 113(5), 750–767. <https://doi.org/10.1108/02635571311324188>
- [17] Alalwan, A. A. (2020). Mobile food ordering apps: An empirical study of the factors affecting customer e-satisfaction and continued intention to reuse. *International Journal of Information Management*, 50(April 2019), 28–44. <https://doi.org/10.1016/j.ijinfomgt.2019.04.008>

#10 (1570695188): Examining the Adoption of Mobile Payment Service: Expectation Confirmation Model with Trust

## #10 ([1570695188](#)): Examining the Adoption of Mobile Payment Service: Expectation Confirmation Model with Trust



Property	Change Add	Value																																								
Conference and track		<a href="#">2021 3rd East Indonesia Conference on Computer and Information Technology (EIconCIT)</a> - <i>The 2021 3rd East Indonesia Conference on Computer and Information Technology.</i>																																								
Authors		<table border="1"> <thead> <tr> <th>Drag to change order</th> <th>Name</th> <th>ID</th> <th>Edit</th> <th>Flag</th> <th>Affiliation (edit for paper)</th> <th>Email</th> <th>Country</th> <th>Email</th> <th>Delete</th> </tr> </thead> <tbody> <tr> <td></td> <td><a href="#">Albertus Dwiyoga Widiantoro</a></td> <td>1610151</td> <td></td> <td></td> <td><a href="#">Soegijapranata Catholic University &amp; Jl. Pawiyatan Luhur 4/1, Indonesia</a></td> <td><a href="mailto:yoga@unika.ac.id">yoga@unika.ac.id</a></td> <td>Indonesia</td> <td></td> <td></td> </tr> <tr> <td></td> <td><a href="#">Bernardinus Harnadi</a></td> <td>1399221</td> <td></td> <td></td> <td><a href="#">Soegijapranata Catholic University, Indonesia</a></td> <td><a href="mailto:bharnadi@unika.ac.id">bharnadi@unika.ac.id</a></td> <td>Indonesia</td> <td></td> <td></td> </tr> <tr> <td></td> <td><a href="#">FX Hendra Prasetya</a></td> <td>1656793</td> <td></td> <td></td> <td><a href="#">Soegijapranata Catholic University, Indonesia</a></td> <td><a href="mailto:hendra@unika.ac.id">hendra@unika.ac.id</a></td> <td>Indonesia</td> <td></td> <td></td> </tr> </tbody> </table>	Drag to change order	Name	ID	Edit	Flag	Affiliation (edit for paper)	Email	Country	Email	Delete		<a href="#">Albertus Dwiyoga Widiantoro</a>	1610151			<a href="#">Soegijapranata Catholic University &amp; Jl. Pawiyatan Luhur 4/1, Indonesia</a>	<a href="mailto:yoga@unika.ac.id">yoga@unika.ac.id</a>	Indonesia				<a href="#">Bernardinus Harnadi</a>	1399221			<a href="#">Soegijapranata Catholic University, Indonesia</a>	<a href="mailto:bharnadi@unika.ac.id">bharnadi@unika.ac.id</a>	Indonesia				<a href="#">FX Hendra Prasetya</a>	1656793			<a href="#">Soegijapranata Catholic University, Indonesia</a>	<a href="mailto:hendra@unika.ac.id">hendra@unika.ac.id</a>	Indonesia		
Drag to change order	Name	ID	Edit	Flag	Affiliation (edit for paper)	Email	Country	Email	Delete																																	
	<a href="#">Albertus Dwiyoga Widiantoro</a>	1610151			<a href="#">Soegijapranata Catholic University &amp; Jl. Pawiyatan Luhur 4/1, Indonesia</a>	<a href="mailto:yoga@unika.ac.id">yoga@unika.ac.id</a>	Indonesia																																			
	<a href="#">Bernardinus Harnadi</a>	1399221			<a href="#">Soegijapranata Catholic University, Indonesia</a>	<a href="mailto:bharnadi@unika.ac.id">bharnadi@unika.ac.id</a>	Indonesia																																			
	<a href="#">FX Hendra Prasetya</a>	1656793			<a href="#">Soegijapranata Catholic University, Indonesia</a>	<a href="mailto:hendra@unika.ac.id">hendra@unika.ac.id</a>	Indonesia																																			
Title		<i>Examining the Adoption of Mobile Payment Service: Expectation Confirmation Model with Trust</i>																																								
Abstract		This study has a purpose to examine the acceptance of mobile payment services by employing a modified ECM model with Trust. Several related studies on e-commerce and mobile payment have been investigated to derive important variables which can be employed on a proposed model. The model expresses the effect of customers' trust on their satisfaction in using mobile payment services and their continuance intention in using it. The online questionnaires constructed based on the proposed model were distributed to mobile payment users to gather their perceptions in using it. The 338 questionnaires gathered were analyzed statistically by SEM to test the hypotheses of the study. The results of the analysis reveal that customers' trust is an important variable to enhance customers' satisfaction and continuance intention in using mobile payment services. Other results indicate that Trust and Confirmation have a direct effect on the Perceived Usefulness of the services. Furthermore, both Perceived Usefulness and Trust will make consumers feel satisfied and tend to continuance their intention in using mobile payment services. This study contributes to financial service providers in delivering an obviousness, how was the trust of services can make consumers feel satisfy and use the service continually.																																								
Category		Full Papers																																								
Topics		Information System																																								



Yoga Widianoro &lt;yoga@unika.ac.id&gt;

---

**[EICONCIT'21] Paper 1570695188 has been registered**

1 message

---

**eiconcit21-chairs@edas.info** <eiconcit21-chairs@edas.info>

Fri, Dec 4, 2020 at 9:11 PM

Reply-To: EICONCIT'21 &lt;eiconcit21-chairs@edas.info&gt;

To: Albertus Dwiyoga Widianoro &lt;yoga@unika.ac.id&gt;

Dear Mr. Albertus Widianoro:

Thank you for registering your paper 1570695188 (*Examining the Adoption of Mobile Payment Service: Expectation Confirmation Model with Trust*) to **2021 3rd East Indonesia Conference on Computer and Information Technology (EIconCIT)**. You still have to upload your manuscript at <https://edas.info/uploadPaper.php?m=1570695188>. Your manuscript can be application/pdf.

You can see all your submissions and their status at

<https://edas.info/index.php?c=27857>using your EDAS user id [yoga@unika.ac.id](mailto:yoga@unika.ac.id).

Once you upload your manuscript, you will receive another email confirmation.

Regards, The conference chairs