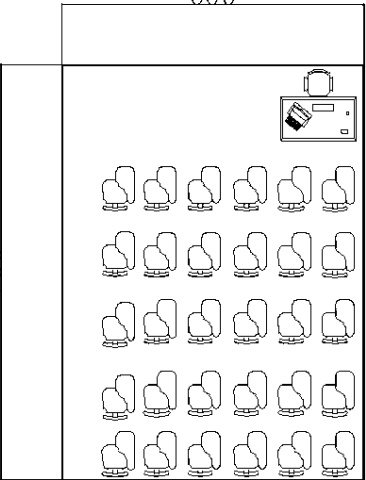
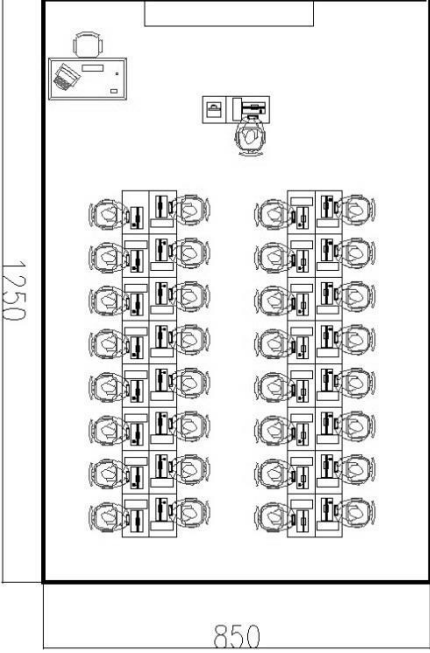
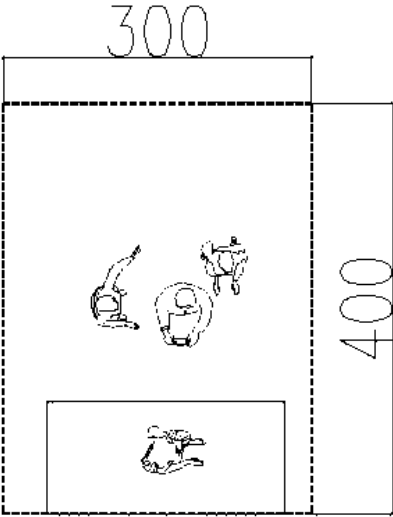
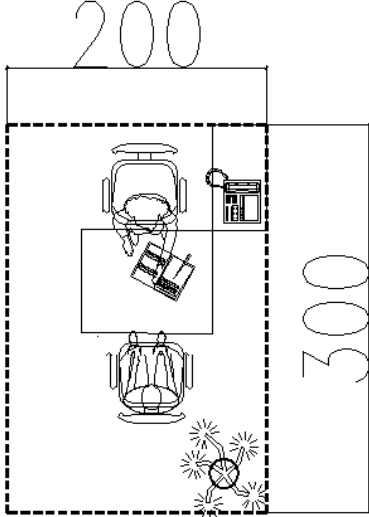

## LAMPIRAN

Tabel studi kebutuhan ruang

No	Nama ruang	Besaran Ruang	Kapasitas	Ukuran
1.	Ruang Kelas kecil		25orang	42m <sup>2</sup>
2.	Ruang Laboratorium Animasi		40 orang	106.25m <sup>2</sup>

3.	Studio Fotografi		6orang	12m <sup>2</sup>
4.	Ruang Konseling		2orang	6m <sup>2</sup>
5.	Ruang Seminar/Serbaguna		500orang	900m <sup>2</sup>

6. Ruang belajar mandiri /Student Lounge

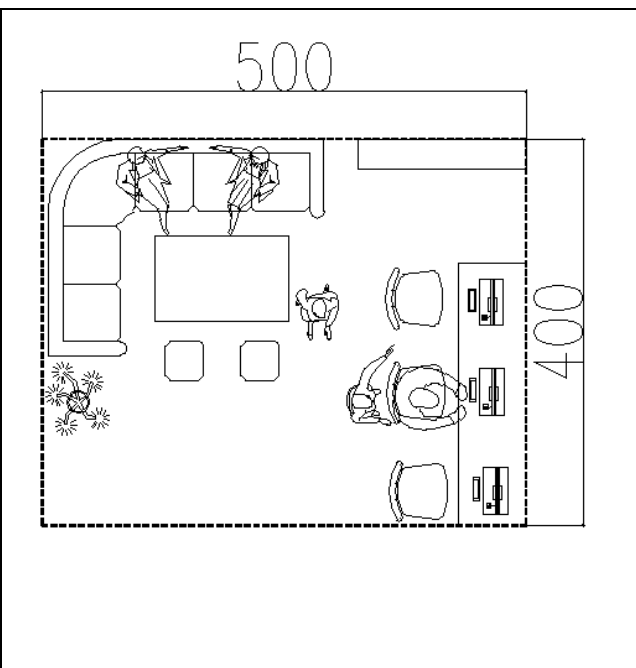

7. Perpustakaan

200 orang

1500m<sup>2</sup>

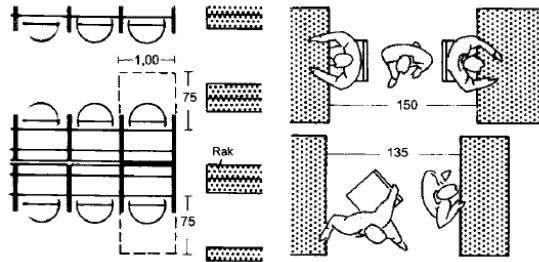
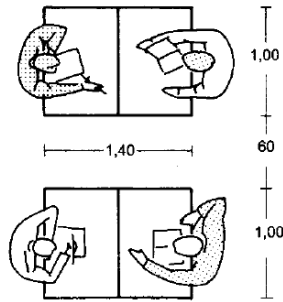

⑨ Meja kerja perseorangan sistem Carrels

⑧ Ruang gerak minimum di dalam jangkauan ruang baca → ⑨

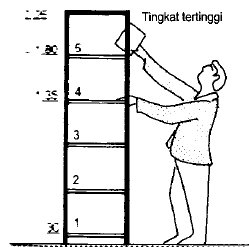

⑩ Rak buku dengan 5 tingkat/bagian

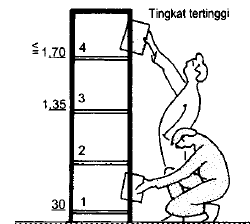

⑪ Rak buku untuk pelajar

Sumber: NEUFERT Data Arsitek 2

8. Ruang Dosen tetap/tidak tetap

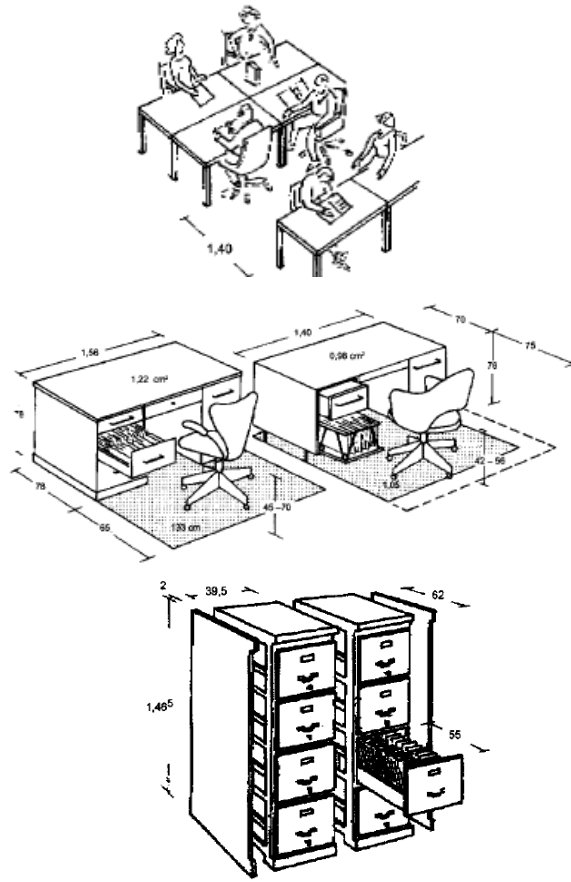

Sumber: Neufert Data Arsitek 2

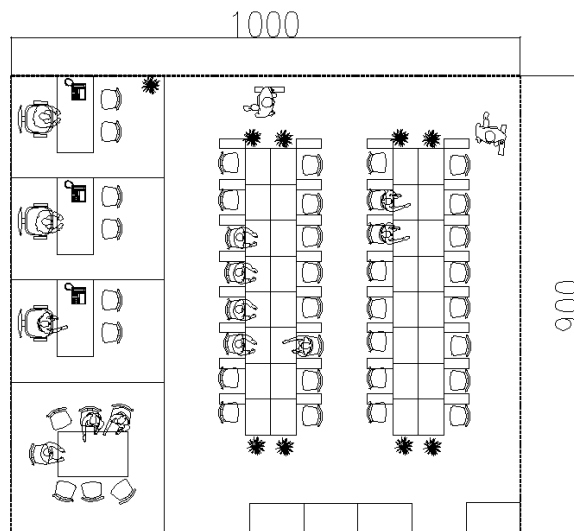

Sumber: Data Pribadi

20 orang (tetap)  
10 orang (tidak tetap)

9. - Ruang Dosen  
- Ruang Wakil Direktur  
- Ruang Sekretaris  
Direktur

Ruang Dosen

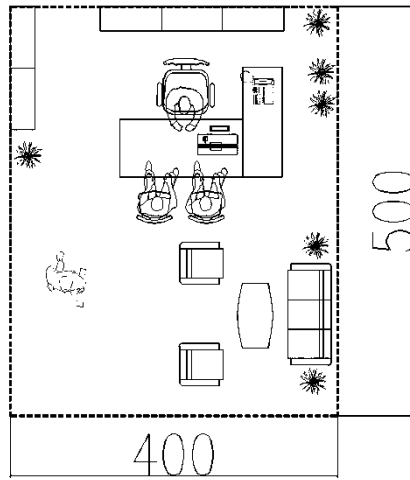

Ruang Wakil Direktur dan Ruang Sekretaris

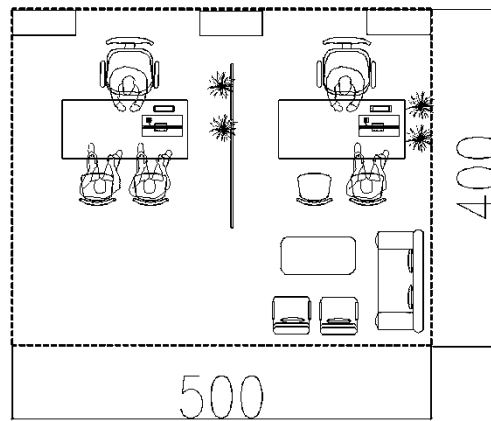

JADWAL PENGGUNAAN KELAS-STUDIO-LABORATORIUM

Semester I												
No	Program Studi	Ruang/Kapasitas	Nama Mata Kuliah									
			Jam	Senin	Jam	Selasa	Jam	Rabu	Jam	Kamis	Jam	Jumat
1	Program Studi Animasi	Ruang kelas A.1.1 (25)	08.30-10.30	Pendidikan Agama(A)	08.30-10.30	Sejarah seni dan Animasi	07.30-09.30	Prinsip dan Teknik Animasi	09.30-11.30	Pendidikan Agama(B)		
		Studio Gambar A.2.1 (50)	10.45-11.30	Menggambar	10.45-11.30	Komunikasi dan Visual						
		Studio Gambar A.2.2 (50)					10.45-11.30	Desain Elementer				
		Lab Animasi (40)			13.00-15.00	Animasi Interaktif I			13.00-15.00	Proses Ide Kreatif		
2	Program Studi Game Technology	Ruang Kelas A.1.1 (25)	13.00-15.00	Pancasila (A)	13.00-15.00	Psikologi Bermain	10.45-11.30	PKN (A)	13.00-15.00	Sejarah Game (B)	07.45-09.30	PKN (B)
		Ruang Kelas A.1.2 (25)	07.30-09.30	Matematika Dasar			07.30-09.30	Sejarah Game (A)	09.30-11.30	Pancasila (B)	09.30-11.30	Kewirausahaan
		Lab. Multimedia A.1.1(40)	10.45-11.30	Pemrograman I	09.30-11.30	Bahasa Inggris 1 (A)					13.00-15.00	Bahasa Inggris 1 (B)
		Studio Gambar A.2.1 (50)					13.00-15.00	Dasar Menggambar	07.30-09.30	Dasar Menggambar		
3	Program Studi Musik dan Produksi Audio	Ruang Kelas A.1.1 (25)	09.00-11.30	Teori Fundamental Mixing (A)			13.00-15.00	Teori Fundamental Mixing (B)	07.30-09.30	Pendidikan Agama (A)	09.30-11.30	Pendidikan Agama (B)
		Ruang Rekaman A.1.1	07.30-09.30	Pelatihan dan Pendengaran Audio I (A)								
		Ruang Rekaman A.1.2	07.30-09.30	Pelatihan dan Pendengaran Audio I (B)								
		Ruang Studio A.2.3 (50)	13.00-15.00	Teori Musik	07.30-09.30	Pelatihan dan Pendengaran Audio I						
						13.00-15.00	Prinsip Dasar Suara					
		Lab Multimedia A.1.1 (40)				15.00-17.00	Digital Audio(A)	07.30-09.30	Komunikasi dan Teknologi Komputer	09.30-11.30	Digital Audio (B)	

Semester II													
No	Program Studi	Ruang/Kapasitas	Nama Mata Kuliah										
			Jam	Senin	Jam	Selasa	Jam	Rabu	Jam	Kamis	Jam	Jumat	
			1	Program Studi animasi	Ruang kelas A.1.1 (25)	13.00-15.00	Bahasa Indonesia (A)	13.00-15.00	Bahasa Indonesia (B)	15.00-17.00	Bahasa Indonesia (c)		
								13.00-15.00	Kecakapan Personal dan antar personal				
	Studio Gambar A.2.1 (50)	07.30-09.00	Studi dan desain karakter								07.30-09.30	Penulisan cerita	
		09.00-11.30	Ilustrasi Visual									dan skenario	
	Lab Animasi (40)				09.00-11.30	Animasi Interaktif 2				15.00-17.00	Animasi Interaktif 1	09.00-11.30	Penyudaraan dan papan cerita
	Ruang Rekaman A.1.1							13.00-15.00	Teknik Rekam dan Editing Suara				
	Ruang Rekaman A.1.2							13.00-15.00	Teknik Rekam dan Editing Suara				
2	Program Studi Game Technology	Ruang Kelas A.1.1 (25)	07.30-09.30	Pendidikan Agama	07.30-09.30	Aljabar Linier (A)					07.30-09.30	Aljabar Linier (c)	
							15.00-17.00	Aljabar Linier (B)					
		Lab Multimedia A1.1	09.30-11.30	Bahasa Inggris 2 (A)				07.30-09.30	Teknik Implementasi Game (B)	09.30-11.30	Mekanika Game	09.30-11.30	Bahasa Inggris (B)
		Lab Multimedia A1.2	13.00-15.00	Praktikum Pemrograman (A)	09.30-11.30	Praktikum Pemrograman (B)	07.30-09.30	07.30-09.30	Teknik Implementasi Game (A)	13.00-15.00	Jaringan Komputer		
		Lab Mutimedia A.1.3						13.00-15.00	Pemrograman 2 (A)			15.00-17.00	Pemrograman 1
3	Program Studi Musik dan Produksi Audio	Ruang Kelas A.1.1					15.00-17.00	Bahasa Indonesia (C)			09.30-11.30	Bahasa Indonesia (B)	
		Ruang Kelas A.1.2	13.00-15.00	Bahasa Indonesia (A)									
		Ruang Studio 2.3	09.30-11.30	Studio Sessions	07.30-09.30	Produksi Komersial Televisi (B)	13.00-15.00	13.00-15.00	Produksi Komersial Televisi (A)			13.00-15.00	Produksi Komersial Televisi (B)
		Ruang Rekaman A.1.1			09.00-11.30	Pengenalan Workshop Digital Audio (A)	09.00-10.30	09.00-10.30	Teknik Mixing (B)	13.00-15.00	Pengenalan Workshop Digital Audio (B)		
		Ruang Rekaman A.1.2			13.00-15.00	Teknik Mixing (A)	07.30-09.30	07.30-09.30	Pelatihan Pendengaran Audio 2 (A)	09.30-11.30	Pelatihan pendengaran Audio 2 (B)		



	Lab. Multimedia A.1.1	07.00-09.30	Bahasa Inggris (A)				07.30-09.30	Bahasa Inggris (B)		
--	-----------------------	-------------	--------------------	--	--	--	-------------	--------------------	--	--

Semester III												
No	Program Studi	Ruang/Kapasitas	Nama Mata Kuliah									
			Jam	Senin	Jam	Selasa	Jam	Rabu	Jam	Kamis	Jam	Jumat
			1	Program Studi Animasi	Ruang kelas A.1.1					15.00-17.00	PKN (A)	
		Ruang kelas A.1.2			15.00-17.00	Pancasila (A)			15.00-17.00	Pancasila (B)		
		Studio Gambar A.2.1	07.30-09.30	Studi Anatomi dan Gerak	07.30-09.30	Sinematografi	09.30-11.30	Desain Game (Interaktif Animasi)			07.30-09.30	Etika Profesi
		Lab. Multimedia A.1.1	13.00-15.00	Animasi 2D (Film Animasi)			13.00-15.00	Integrasi (Film Animasi)				
			15.00-13.00	Game 2D (Interaktif Animasi)								
2	Program Studi Game Technology	Ruang Kelas A1.1	09.30-11.30	Narasi Interaktif	07.30-9.30	Narasi Interaktif						
		Ruang Studio A.2.3	07.30-09.30	Geometry dan Visualisasi Ekspresi			07.30-09.30	Prinsip Komposisi dan Desain				
		Lab Multimedia A.1.1	13.00-15.00	Praktikum Pemrograman 2 (A)	09.30-11.30	Pemrograman Lanjut			07.30-09.30	Pemrograman Komputer dan Aided	07.30-09.30	Pemrograman Jaringan Komputer
		Lab Multimedia A.1.2	13.00-15.00	Praktikum Pemrograman 2 (B)	13.00-15.00	Praktikum Pemrograman 2 (C)	13.00-15.00	Desain Grafik dan Kebutuhan User				
3	Program Studi Musik dan Produksi Audio	Ruang Kelas A.1.1	13.00-15.00	Kewirausahaan (A)	13.00-15.00	Kewirausahaan (B)	13.00-15.00	Pancasila(A)	07.30-09.30	PKN (A)	07.30-09.30	PKN (B)
		Ruang Kelas A.1.2					15.00-17.00	Pancasila ( C )	09.30-11.30	PKN ( C )	13.00-15.00	Pancasila(B)
		Ruang Rekaman A.1.1	07.30-11.30	Workshop Digital Audio (A)	07.30-11.30	Produksi Live-Sound (A)	09.30-11.30	Advance Audio Session	13.00-17.00	Teknik Mixing Lanjutan		
		Ruang Rekaman A.1.2	07.30-11.30	Workshop Digital Audio (B)	07.30-11.30	Produksi Live-Sound (B)						

## Semester IV

No	Program Studi	Ruang/Kapasitas	Nama Mata Kuliah										
			Jam	Senin	Jam	Selasa	Jam	Rabu	Jam	Kamis	Jam	Jumat	
1	Program Studi Animasi	Studio Gambar A.2.1	13.00-15.00	Animasi Ekspresi dan Percakapan (A) (Film Animasi)	07.30-09.30	Lingkungan dan antar muka Game							
		Studio Gambar A.2.2	13.00-15.00		Animasi Ekspresi dan Percakapan (B) (Film Animasi)								
		Lab. Animasi	07.30-09.30	Animasi 3D (Film Animasi)	09.30-11.30	Teknik render (Film Animasi) (A)	13.00-15.00	Teknik render (Film Animasi) (B)	13.00-15.00	Animasi 3D untuk Game			
		Studio Modelling / Motion capture					07.30-13.00	Permodelan 3D (Film Animasi)	07.30-13.00	Permodelan 3D untuk Game			
											07.30-09.30	Mesin Game (A)	
											13.00-15.00	Mesin Game (B)	
2	Program studi Game Technology	Ruang Kelas A.1.1	07.30-09.30	Bahasa Indonesia				13.00-15.00	Matematika Diskrit	13.00-15.00	Matematika Diskrit		
									07.30-09.30	Aljabar Linier			
		Ruang Studio A.2.3	13.00-15.00	Dasar dan Ekspresi Visual							07.00-09.30	Etika Profesional	
											13.00-15.00	Komunikasi dan Interpersonal kerja	
		Ruang Studio A.2.4				07.30-09.30	Workshop Story Board						
		Lab.Multimedia A.1.1				09.30-11.30	Grafika Komputer (A)	07.30-09.30	Struktur Data	09.30-11.30	Sistem Operasi dan antar muka (A)		
									09.30-11.30	Struktur dan Pemakaian Teknologi Game			
Lab.Multimedia A.1.2				09.30-11.30	Grafika Komputer (B)			09.30-11.30	Sistem Operasi dan antar muka(B)				
3	Program Studi Musik dan Produksi Audio	Ruang Kelas A.2.1	07.30-09.30	Prinsip dasar Elektronik					09.30-11.30	Kepemimpinan pengembangan karir dan Industri Musik (A)	09.30-11.30	Kepemimpinan pengembangan karir	
		Ruang Rekaman A.1.1				13.00-15.00	MIDI Programing					dan industri Musik (B)	
		Ruang Rekaman A.1.2	09.30-11.30	Produksi Live sound Lanjutan				09.30-11.30	Produksi Live Sound Lanjutan				

						13.00-15.00	Teknik Audio Teknologi (A)	07.30-09.30	Teknik Audio Teknologi (B)		
		Lab.Multimedia			15.00-17.00	MIDI Proqraming					

Semester V												
No	Program Studi	Ruang/Kapasitas	Nama Mata Kuliah									
			Jam	Senin	Jam	Selasa	Jam	Rabu	Jam	Kamis	Jam	Jumat
			1	Program Studi Animasi	Ruang Kelas A.1.1			07.30-09.30	Kewirausahaan			
		Ruang Rekaman A.1.1	07.30-09.30	Produksi Audio dan Midi (A)			09.30-11.30	Produksi Audio dan Midi (B)			09.30-11.30	Produksi Audio Midi (C)
		Ruang Studio A.2.3	09.30-11.30	Manajemen Produksi Game (A)					09.30-11.30	Manajemen Produksi Game (B)		
		Lab. Animasi			13.00-15.00	Efek Khusus Digital	13.00-15.00	Kecerdasan Buatan untuk Game (A)	13.00-15.00	Game 3D	07.30-09.30	Kecerdasan Buatan untuk Game (B)
2	Program Studi Game Technology	Ruang Kelas A.1.1	07.30-09.30	Pendidikan Agama (A)			07.30-09.30	Pendidikan Agama (B)	09.30-11.30	Pendidikan Agama (c)		
									13.00-15.00	Manajemen Produksi Game	09.30-11.30	Praktek Kerja Lapangan
		Ruang Studio A.2.3	09.30-11.30	Desain Level 2D								
		Lab.Multimedia A.1.1	13.00-15.00	2D Raster dan Vector Graphics Untuk Desain	09.30-11.30	Produksi 3D untuk Desainer					13.00-15.00	Workshop Pembuatan Game (A)
		Lab Multimedia A 1.2			13.00-15.00	Kecerdasan Buatan Untuk Game	09.30-11.30	Sistem Digital			13.00-15.00	Workshop Pembuatan Game (B)
		Lab Multimedia A.1.3									13.00-15.00	Workshop Pembuatan Game (C)
		Ruang Rekaman A.1.1			07.30-09.30	Desain Musik dan Sound	13.00-15.00	Komposer Musik (A)	07.30-09.30	Komposer Musik (B)		
3	Program Studi Musik dan	Ruang Kelas A.1.1									13.00-15.00	Praktek Kerja Lapangan
		Ruang Rekaman A.1.1	07.30-09.30	Produksi Audio (A)	09.30-11.30	Produksi Audio (B)	07.30-09.30	Produksi Audio (C)				
	Produksi Audio	Ruang Multimedia A.1.1	09.30-11.30	Bisnis Musik dan Studio							07.30-09.30	Produksi Komersial Televisi
		Ruang studio A.2.3									09.30-	Dasar Desain

													11.30	Grafis
--	--	--	--	--	--	--	--	--	--	--	--	--	-------	--------

Semester V													
No	Program Studi	Ruang/Kapasitas	Nama Mata Kuliah										
			Jam	Senin	Jam	Selasa	Jam	Rabu	Jam	Kamis	Jam	Jumat	
			1	Program Studi Amiasi	Ruang Studio Akhir 1.1	07.30-17.00	TUGAS AKHIR						
2	Program Studi Game Technology	Ruang Studio Akhir 1.2	07.30-17.00	TUGAS AKHIR									
3	Program Studi Musik dan Produksi Audio	Ruang Studio Akhir 1.3	07.30-17.00	TUGAS AKHIR									