

2020a

Inter_ST-Certificate-ppt-accept-abstract_ICSAF_oral_2020_r...

 Unika Soegijapranata1

Document Details

Submission ID

trn:oid::28973:130074655

Submission Date

Mar 6, 2026, 12:07 PM GMT+7

Download Date

Mar 6, 2026, 12:09 PM GMT+7

File Name

2020a Inter_ST-Certificate-ppt-accept-abstract_ICSAF_oral_2020_repository.pdf

File Size

5.7 MB

23 Pages

2,510 Words

14,337 Characters

5% Overall Similarity

The combined total of all matches, including overlapping sources, for each database.

Filtered from the Report

- ▶ Bibliography
- ▶ Quoted Text
- ▶ Cited Text
- ▶ Small Matches (less than 10 words)

Exclusions

- ▶ 2 Excluded Sources

Match Groups

- 9 Not Cited or Quoted 5%**
Matches with neither in-text citation nor quotation marks
- 0 Missing Quotations 0%**
Matches that are still very similar to source material
- 0 Missing Citation 0%**
Matches that have quotation marks, but no in-text citation
- 0 Cited and Quoted 0%**
Matches with in-text citation present, but no quotation marks

Top Sources

- 5% Internet sources
- 1% Publications
- 1% Submitted works (Student Papers)

Integrity Flags

1 Integrity Flag for Review

- Hidden Text**
573 suspect characters on 15 pages
Text is altered to blend into the white background of the document.

Our system's algorithms look deeply at a document for any inconsistencies that would set it apart from a normal submission. If we notice something strange, we flag it for you to review.

A Flag is not necessarily an indicator of a problem. However, we'd recommend you focus your attention there for further review.

Match Groups

- **9 Not Cited or Quoted 5%**
Matches with neither in-text citation nor quotation marks
- **0 Missing Quotations 0%**
Matches that are still very similar to source material
- **0 Missing Citation 0%**
Matches that have quotation marks, but no in-text citation
- **0 Cited and Quoted 0%**
Matches with in-text citation present, but no quotation marks

Top Sources

- 5% Internet sources
- 1% Publications
- 1% Submitted works (Student Papers)

Top Sources

The sources with the highest number of matches within the submission. Overlapping sources will not be displayed.

1	Internet		
		docplayer.net	<1%
2	Internet		
		www.bitcongress.com	<1%
3	Internet		
		docslib.org	<1%
4	Internet		
		repository.au.edu	<1%
5	Internet		
		icsaf.org	<1%
6	Internet		
		researchapi.fju.edu.tw	<1%
7	Publication		
		Chibuye Bitwell, Indra Singh Sen, Chimuka Luke, Maseka Kenneth Kakoma. "A rev...	<1%
8	Internet		
		search.crossref.org	<1%

Ultrasound assisted extraction of fucoxanthin and polyphenols from brown seaweed *Turbinaria decurrens*: a study on the effect of time and temperature

- Probo Y. Nugrahedi*, Riyan Anggriawan, F. Budi Setiawan#
- *Dept. of Food Technology & #Dept. of Electrical Engineering, Univ. Katolik Soegijapranata



Outline



Introduction



Previous studies



Aim

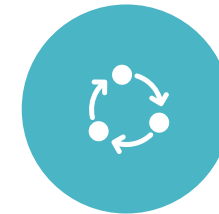

Method



Results and discussion



Conclusion and further study



Introduction

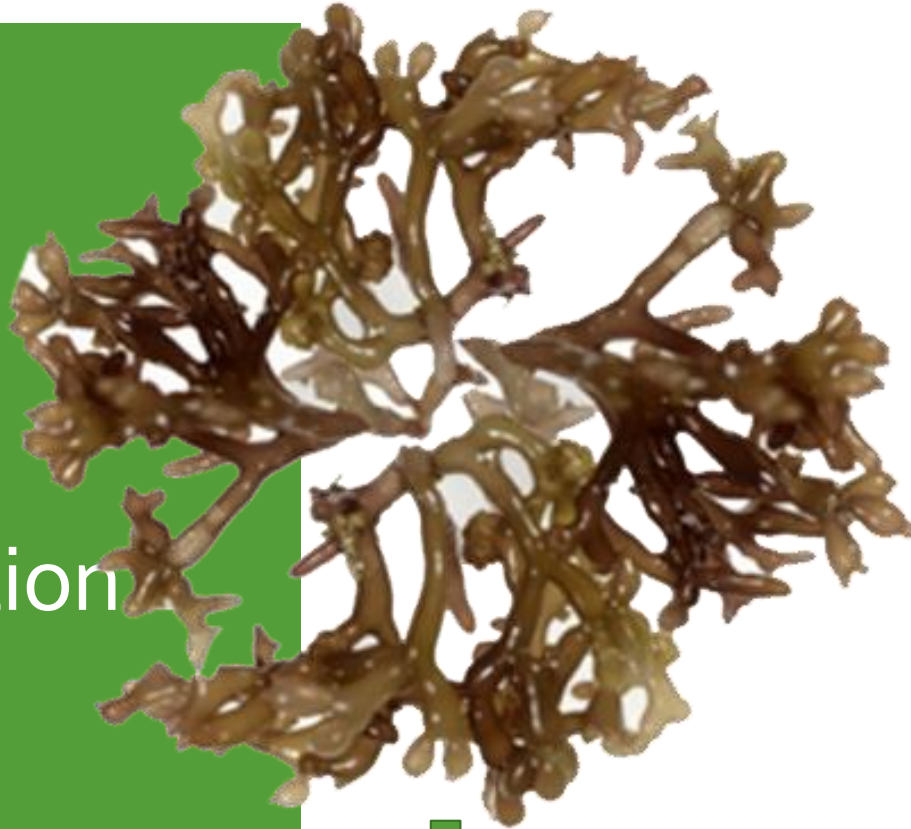

Carotenoids

Polyphenols

Fatty acids

Others

**Health
promoting
compounds**





Introduction

Extraction methods

“green”

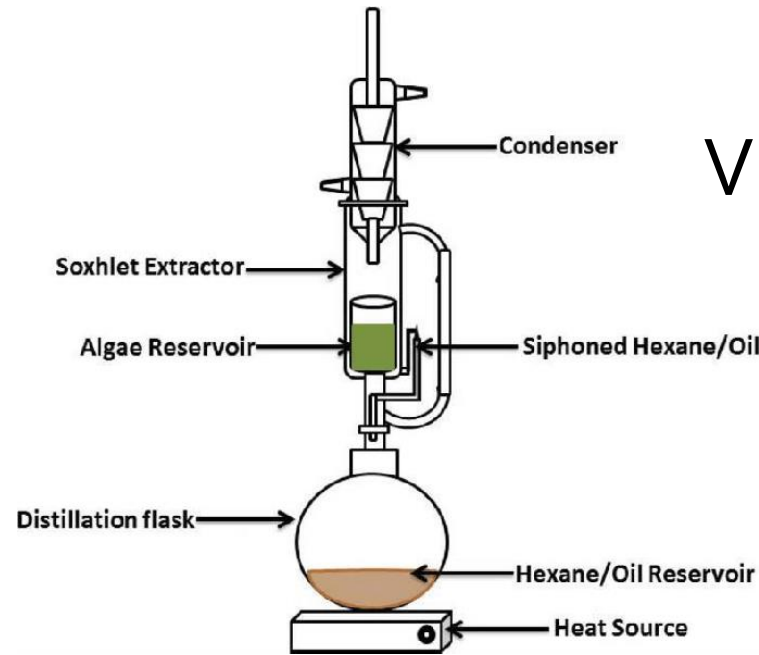

VS.

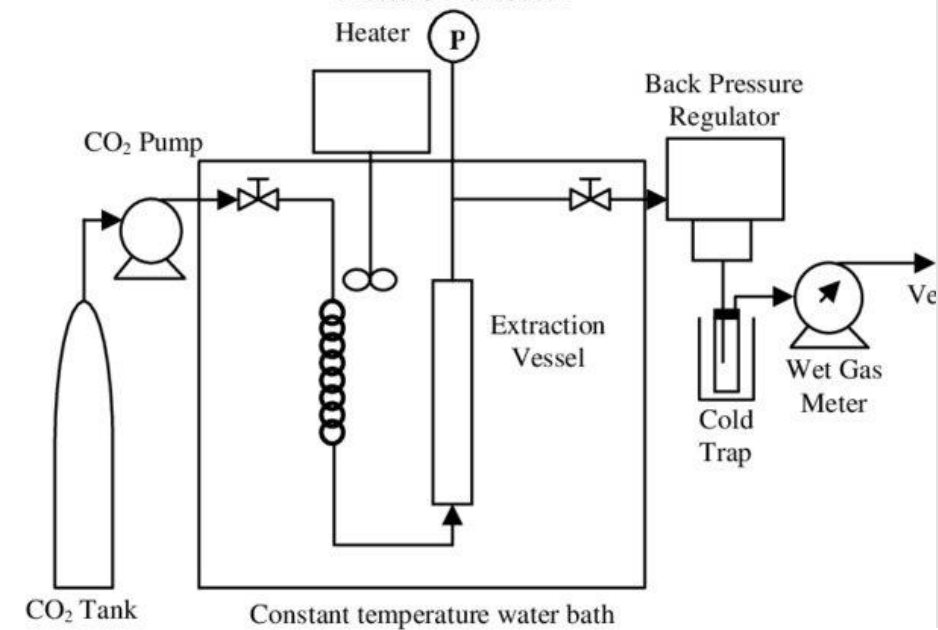

Ultrasound Assisted Extraction (UAE)

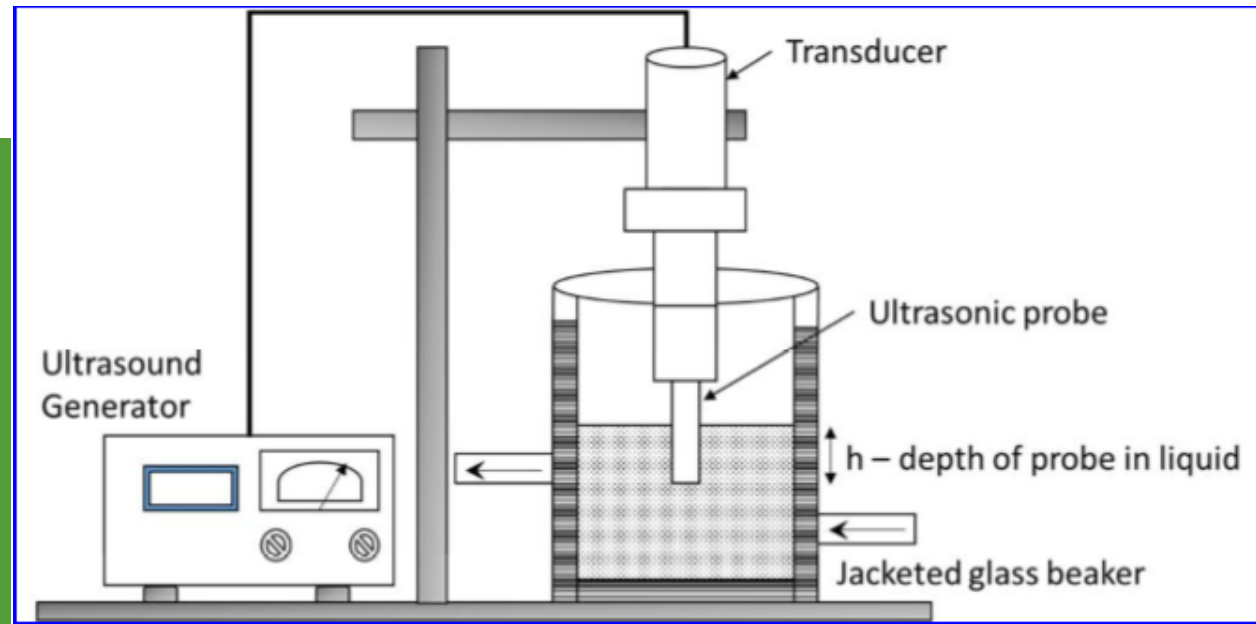

- Low temperature
- Fast extraction
- Environment-friendly
- Low cost

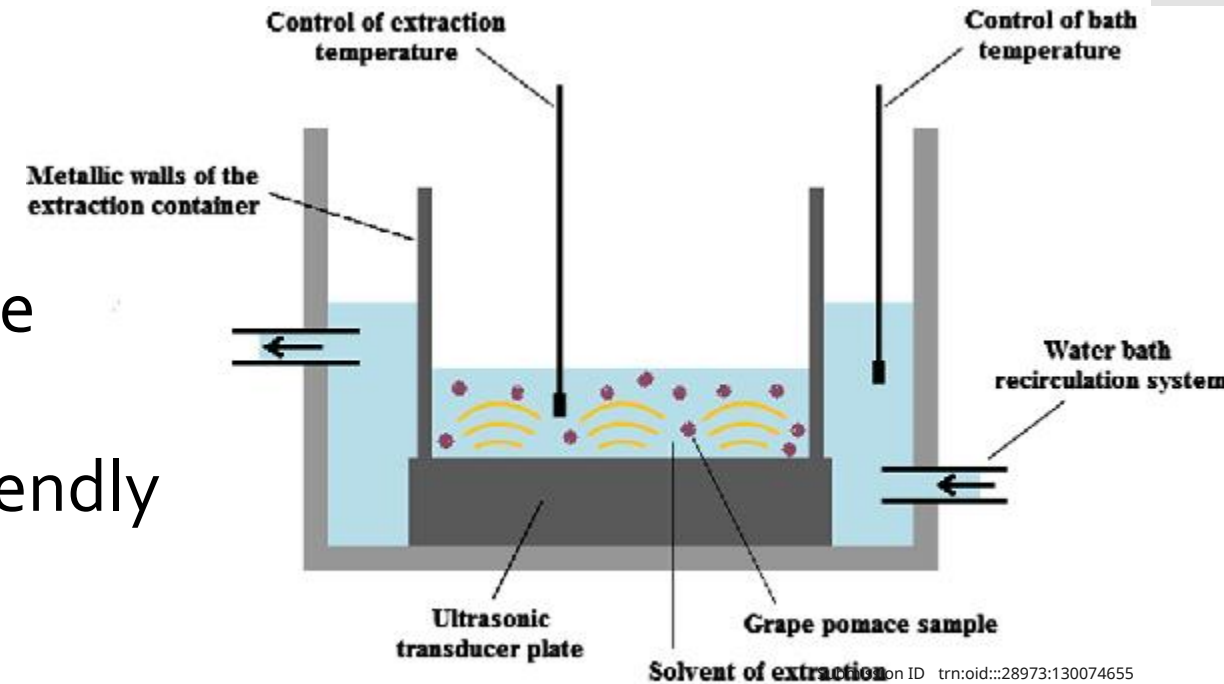

Some of previous studies on the UAE on seaweeds' bioactives

Species	Freq (kHz); Pwr (W)	Solvent	Temp (°C) & Time (min)	Concentration			Ref.
Brown Seaweed							
<i>Hormosira banksii</i>	50; 150, 200, 250	70% EtOH	30;40;50 & 20;40;60	Polyphenols	14.46-23.12	mg/g	[1]
<i>Ascophyllum nodosum</i>	20; 750	HCl 0, 0.03, 0.06M	n.a. & 5, 15, 25	Polyphenols Fucose Uronic Acid	63.54-139.73 11.62-86.63 46.46-117.44	mg GAE/g mg/g mg/g	[2]
<i>Ascophyllum nodosum</i>	20; 750	H ₂ O or HCl 0.01M	n.a. & 15	Polyphenols Laminarin	0.128-0.156 5.290-5.822	mg GE/g %	[3]
<i>Laminaria hyperborea</i>	20; 750	H ₂ O or HCl 0.01M	n.a. & 15	Polyphenols Laminarin	0.343-0.365; 5.975-6.240	mg GE/g %	[3]
<i>Ecklonia cava</i>	40; 200	H ₂ O or MeOH	30 & 360; 720	Polyphenols	34.2-61.5	mg/g	[4]

Species	Freq (kHz); Pwr (W)	Solvent	Temp (°C) & Time (min)	Concentration			Ref.
<i>Sargassum muticum</i>	50/60; 400	H ₂ O	50 & 60	Polyphenols	235 ± 5.57	µgCE /g	[5]
<i>Sargassum muticum</i>	n.a.; 78 W Ampltd	70% EtOH	80 & 10	Fucoxanthin	613.6 ± 9.1	µg/g	[6]
Green seaweeds							
<i>Codium tomentosum</i>	50/60; 400	H ₂ O	50 & 60	Polyphenols	141.1 ± 9.79	µgCE /g	[5]
Red seaweeds							
<i>Osmundea pinnatifida</i>	50/60; 400	H ₂ O	50 & 60	Polyphenols	103.7 ± 1.67	µgCE /g	[5]
<i>Laurencia obtuse</i>	40; 250	95% EtOH	30, 40, 50 & 30, 45, 50	Polyphenols	8.98 - 25.95	mg GAE/g	[7]



Results of the mini review on UAE

- Concentration of polyphenolic and carotenoid compounds is highly depend on the nature of the seaweeds and the extraction parameters, including time-temperature, power, frequency, amplitude, and solvent (type and ratio)
- The diversity of the bioactive concentrations indicates possible interactions between extraction parameters influencing the yield



Aim

To study the effect of UAExtraction parameters (time-temperature as prelim.) on the concentration of health promoting polyphenols and fucoxanthin, and antioxidant activity from brown seaweed *Turbinaria decurrens*



Method

A preliminary study

- *Turbinaria decurrens* extracted with UAE (bath type) at 80 kHz
- Solvent Ethanol 75%, ratio 25:1
- Treatments:
 - Time 30, 60, 90 min
 - Temperature 30, 50, 70 °C
- Measurement: Poliphenols, Fucoxanthins, Antioxidant activity



Results and Discussion

Total polyphenols [mg GAE/g db]

Time (min)	Temperature (°C)		
	30	50	70
30	10.8 ± 0.98 ^a	11.1 ± 0.53 ^b	11.3 ± 0.69 ^c
60	10.3 ± 0.65	11.6 ± 0.63	13 ± 0.83
90	10 ± 0.21	11 ± 1.58	13.5 ± 0.96

Previous studies showed highly varied polyphenolic content in brown seaweeds [0.13 - 140 mg GAE/g]



Results and Discussion

Fucoxanthin [mg/kg db]

Time (min)	Temperature (°C)		
	30	50	70
30	88.59 ± 10.91	119.37 ± 70.29	123.74 ± 33.84
60	94.49 ± 18.64	140.07 ± 10.87	198.87 ± 67.06
90	60.99 ± 20.48	205.45 ± 21.82	131.42 ± 20.82

Fucoxanthin in *Sargassum muticum* = 613 mg/kg [UAE condition: EtOH 70%, 80°C, 10 min] (Subramanian *et al.*, 2013)



Results and Discussion

Antioxidant activity (DPPH)

- Relatively similar between treatments
 - 0.552 mg/g Trolox equivalent
 - 0.580 mg/g Ascorbic acid equivalent
- Antioxidant activity of *H. banksia* (UAE 50 kHz, 150-250W, 70% EtOH, 30-50 °C, 20-60 min -- Dang et al., 2017):
 - ABTS: 53.65 – 85.64 mg/g
 - DPPH: 32.29 – 47.24 mg/g
 - FRAP: 5.46 – 12.77 mg/g



Conclusion and Further Studies

- UAE for 60 min, at 50 & 70 °C both led to the highest and not significantly different polyphenol concentration
- The highest fucoxanthin was obtained by UAE for 60 min, 70 °C & 90 min, 50 °C.

Further studies:

- Effect of UAE time-temperature, power, frequency, and solvent on bioactive concentration
- Optimizing UAE parameters to obtain the optimum concentration of bioactive compounds

Acknowledgment

Research on the application of ultrasonic assisted extraction method on seaweed is financially supported by *Direktorat Riset dan Pengabdian Masyarakat (DRPM) Indonesia No. 010/L6/AK/SP₂H.1/PENELITIAN/2019.*



Thank You



ICSAF
2020
November 6th to 7th
TAIWAN

FUTURE TRENDS IN FOOD SCIENCE AND TECHNOLOGY

4th International Conference on Sustainable
Global Agriculture and Food (ICSAF 2020)

Acceptance Letter

October 28, 2020

Dear Probo Nugrahedi,

We are very pleased to confirm that your submission entitled below has been accepted for the 4th ICSAF in New Taipei City, Taiwan, November 6-7, 2020.

Ultrasound assisted extraction of fucoxanthin and polyphenols from brown seaweed *Turbinaria decurrens*: a study on the effect of time and temperature

Paper ID: ICSAF-O006 [FC]

Presentation Type: Oral

Authors: Probo Y. Nugrahedi, Riyan Anggriawan, F. Budi Setiawan

Affiliation: Soegijapranata Catholic University

Session/Topic: Session B3/Food chemistry and analysis [FC]

Please check the conference information given on the ICSAF 2020 in Taiwan website (<https://icsaf.org/>) for the details of registration and paper upload process. The presentation guideline and format was shown in the conference website. You can check the session you will be presenting from the conference program to be announced on the website soon.

We look forward to your presentation and participation in ICSAF 2020. Please do not hesitate to contact us should you require further information and/or guidance.

Yours Sincerely,



Prof. Bing-Huei Chen
Chairman of the Organizing Committee

ICSAF

Abstract submission deadline: Sep xx, 2020

I would like to attend and present: **Oral** Poster Oral and Poster

Poster or Oral Topics:

Ultrasound assisted extraction of fucoxanthin and polyphenols from brown seaweed *Turbinaria decurrens*: a study on the effect of time and temperature

Probo Y. Nugrahedhi ¹, Riyan Anggriawan, F. Budi Setiawan ²

¹) Department of Food Technology, ²) Department of Electrical Engineering,
Soegijapranata Catholic University, Semarang, Indonesia

Abstract

Seaweeds are widely reported to contain health promoting compounds, including polyphenols and carotenoids. The compounds have been extracted using either conventional or “green” methods. The green methods, such as supercritical fluid, ultrasound assisted, and microwave assisted extraction methods, are gaining more popularity due to some advantages, such as less volume of solvent and shorter extraction time to obtain an optimum yield. This preliminary study aims to investigate the effect of time (30, 60, 90 min) and temperature (30, 50, 70 °C) of the ultrasound assisted extraction method on the polyphenols, fucoxanthin, and antioxidant activities of brown seaweed *Turbinaria decurrens*. Results show that higher temperature increased the total polyphenols but not the extraction time, Meanwhile, there was no significant difference of fucoxanthin concentration and antioxidant activity obtained from high extraction temperature and time. The research is continued to investigate the effect of ultrasound frequency, solvent type and ratio, and power. Identifying the extraction parameters and how these can affect to the amount of the yield and bioactive compounds will be beneficial to design the optimum ultrasound assisted extraction method.

Keywords: *seaweed, ultrasound assisted extraction, fucoxanthin, polyphenols, antioxidant*

***Presenting author information**

Full name: Probo Y. Nugrahedhi

Email: probo@unika.ac.id

Telephone: +62 812 285 3678



The 4th International Conference on
Sustainable Global Agriculture and Food

(<https://icsaf.org>)



Oral Presentation

Home (<https://icsaf.org>) » Presentation (<https://icsaf.org/presentation>)

ICSAF 2020 Scientific Program

All presentation video can be available for watching online after conference close, only to those who have registered.



November 6

Plenary Lectures



Zoom ID: **805 549 8081** PW: **fg302**

9:10-12:00 Room: FG302

Moderators: Dr. Jung-Feng Hsieh

Time	Topic	Abstract	Video
PL1 9:10	<p>ICSAF-0001 Development of lycopene chylomicron into a botanic drug: from bench to bedside</p> <p>Dr. Bing-Huei Chen (Professor)</p> <p>Department of Food Science, Fu Jen Catholic University (Taiwan)</p>	 <p>Abstract</p> <p>(https://icsaf.org/wp-content/uploads/2020/11/0001.pdf)</p>	
PL2 9:40	<p>ICSAF-0002 EPR by F&B industry in Indonesia: A plastic waste reduction opportunity</p> <p>Dr. Budi Widianarko (Professor)</p> <p>Department of Food Technology, Soegijapranata Catholic University Semarang (Indonesia)</p>	 <p>Abstract</p> <p>(https://icsaf.org/wp-content/uploads/2020/11/0002.pdf)</p>	



PL3 10:40	ICSAF-0003 Covid-19 pandemic or biological weapon Dr. Churdchai Cheowtirakul (Professor) Faculty of Biotechnology, Assumption University (Thailand)	 (https://icsaf.org/wp-content/uploads/2020/11/0003.pdf)	
PL4 11:20	ICSAF-0004 Brackish algae in Mekong Delta Vietnam – A sustainable material source for production of bioethanol, plant-based protein and bioactive peptides Dr. Kim Anh Hoang (Associate Professor) Food Technology Faculty, Saigon Technology University (Vietnam)	 (https://icsaf.org/wp-content/uploads/2020/11/0004.pdf)	

Scientific Session A





Zoom ID: **805 549 8081** PW: **fg302**

13:00-14:20 Room: FG302



Topic: Nutrition and biochemistry [NB]

Food chemistry and analysis [FC]

Moderators: Dr. Chun-Ping Lu

Time	Topic	Abstract	Video
A1 13:00	ICSAF-0016 [NB] Functional components and anti-inflammatory activity of <i>Nostoc commune</i> ethanol extract Min-Hsing Ho Department of Food Science, Fu Jen Catholic University (Taiwan)	 (https://icsaf.org/wp-content/uploads/2020/11/0016_145.pdf)	 (https://icsaf.org/wp-content/uploads/2020/11/ICSAF-0016-A1.mp4)
A2 13:20	ICSAF-0012 [NB] Development of heat sealable edible film and potential use for instant foods The Dong Phan Food Technology Faculty, Saigon Technology University (Vietnam)	 (https://icsaf.org/wp-content/uploads/2020/11/0012_132.pdf)	 (https://icsaf.org/wp-content/uploads/2020/11/ICSAF-0012-A2.mp4)
A3 13:40	ICSAF-0017 [FC] Study the phenolic compound in <i>Luffa cylindrica</i> extract and its hepatoprotective effect Shao-Ling Sung Department of Food Science, Fu Jen Catholic University (Taiwan)	 (https://icsaf.org/wp-content/uploads/2020/11/0017_147.pdf)	



<p>A4</p> <p>14:00</p>	<p>Page 23 of 26 - Integrity Submission ICSAF-0015 [FC]</p> <p>Exploiting albumins and glutelins from Brackish gutweed (<i>Enteromorpha</i> sp.) and evaluating their functional properties</p> <p>Ngoc Hieu Tran</p> <p>Food Technology Faculty, Saigon Technology University (Vietnam)</p>	<p></p> <p>(https://icsaf.org/wp-content/uploads/2020/11/0015_144.pdf)</p>	<p></p> <p>(https://icsaf.org/wp-content/uploads/2020/11/ICSAF-0015-A4.mp4)</p>
------------------------	--	---	---

Scientific Session B









Zoom ID: 885 429 9192 PW: fg202

13:00-14:20 Room: FG202

Topic: Food chemistry and analysis [FC]

Agricultural Science [AS]

Moderators: Dr. Shaun C. Chen

Time	Topic	Abstract	Video
<p>B1</p> <p>13:00</p>	<p>ICSAF-0009 [FC]</p> <p>In search of standard methods for extraction and detection of microplastics in seafood using micro-Fourier transform infrared (FTIR) measurement</p> <p>Inneke Hantoro</p> <p>Department of Food Technology, Soegijapranata Catholic University Semarang (Indonesia)</p>	<p></p> <p>(https://icsaf.org/wp-content/uploads/2020/11/0009_128.pdf)</p>	<p></p> <p>(https://icsaf.org/wp-content/uploads/2020/11/ICSAF-0009-B1.mp4)</p>
<p>B2</p> <p>13:20</p>	<p>ICSAF-0007 [FC]</p> <p>Formation of peroxide and free fatty acids in palm cooking after repeated heating as confirmed by Fourier transform infrared spectroscopy (FTIR) measurements</p> <p>Mellia Harumi</p> <p>Department of Food Technology, Soegijapranata Catholic University Semarang (Indonesia)</p>	<p></p> <p>(https://icsaf.org/wp-content/uploads/2020/11/0007_106.pdf)</p>	<p></p> <p>(https://icsaf.org/wp-content/uploads/2020/11/ICSAF-0007-B2.mp4)</p>
<p>B3</p> <p>13:40</p>	<p>ICSAF-0006 [FC]</p> <p>Ultrasound assisted extraction of fucoxanthin and polyphenols from brown seaweed <i>Turbinaria decurrens</i>: a study on the effect of time and temperature</p> <p>Probo Nugraedi</p> <p>Department of Food Technology, Soegijapranata Catholic University Semarang (Indonesia)</p>	<p></p> <p>(https://icsaf.org/wp-content/uploads/2020/11/0006_98.pdf)</p>	<p></p> <p>(https://icsaf.org/wp-content/uploads/2020/11/ICSAF-0006-B3.mp4)</p>
<p>B4</p> <p>14:00</p>	<p>ICSAF-0014 [AS]</p> <p>The use of isolated lipase production microbes from liquid microbial consortium for wastewater treatment</p> <p>Wei-Ju Liao</p> <p>Faculty of Biotechnology, Assumption University (Thailand)</p>	<p></p> <p>(https://icsaf.org/wp-content/uploads/2020/11/0014_135.pdf)</p>	<p></p> <p>(https://icsaf.org/wp-content/uploads/2020/11/ICSAF-0014-B4.mp4)</p>



Scientific Session C







Zoom ID: 805 549 8081 PW: fg302

14:40-16:00 Room: FG302

Topic: Food chemistry and analysis [FC]

Food process and engineering [FP]

Moderators: Dr. Chun-Yao Yang

Time	Topic	Abstract	Video
C1 14:40	<u>ICSAF-0008 [FC]</u> Analysis of ginseng extracts by UPLC-MS/MS and preparation of nanoemulsions and liposomes Chen-Te Jen Department of Food Science, Fu Jen Catholic University (Taiwan)	 (https://icsaf.org/wp-content/uploads/2020/11/0008_126.pdf)	 (https://icsaf.org/wp-content/uploads/2020/11/ICSAF-0008-C1.mp4)
C2 15:00	<u>ICSAF-0018 [FP]</u> Effects of microwave heating and grain moisture on the popping quality of sorghum Tzu-Yin Chen Department of Food Science, Fu Jen Catholic University (Taiwan)	 (https://icsaf.org/wp-content/uploads/2020/11/0018_151.pdf)	 (https://icsaf.org/wp-content/uploads/2020/11/ICSAF-0018-C2.mp4)
C3 15:20	<u>ICSAF-0019 [FP]</u> Optimization the process conditions of vacuum drying of nutmeg seed oleoresin using response surface method Victoria Kristina Ananingsih Department of Food Technology, Soegijapranata Catholic University Semarang (Indonesia)	 (https://icsaf.org/wp-content/uploads/2020/11/0019_157.pdf)	
C4 15:40	<u>ICSAF-0013 [FP]</u> Study on enzyme assisted extraction of polyphenol from watermelon rind Tac Dat Trinh Ngo Food Technology Faculty, Saigon Technology University (Vietnam)	 (https://icsaf.org/wp-content/uploads/2020/11/0013_133.pdf)	 (https://icsaf.org/wp-content/uploads/2020/11/ICSAF-0013-C4.mp4)

Scientific Session D







Zoom ID: 885 429 9192 PW: fg202

14:40-16:30 Room: FG202

Topic: Food microbiology and safety [FM]

Food chemistry and analysis [FC]

Moderators: Dr. Bang-Yuan Chen

Time	Topic	Abstract	Video
D1 14:40	ICSAF-0011 [FM] The antibacterial activity of difference preparation methods of <i>Centella asiatica</i> extract-loaded nanoparticles Kittiya Kesornbuakao Faculty of Biotechnology, Assumption University (Thailand)	 (https://icsaf.org/wp-content/uploads/2020/11/0011_130.pdf)	
D2 15:00	ICSAF-0010 [FC] Collagen determination from sea cucumber for skincare application Watanya Chaisayan Faculty of Biotechnology, Assumption University (Thailand)	 (https://icsaf.org/wp-content/uploads/2020/11/0010_129.pdf)	 (https://icsaf.org/wp-content/uploads/2020/11/ICSAF-0010-D2.mp4)
D3 15:20	ICSAF-0005 [FC] Formulation of low GI RS3-rice and plant-based ingredients into beverage for elderly people Pattarawadee Watanakijcharoenman Faculty of Biotechnology, Assumption University (Thailand)	 (https://icsaf.org/wp-content/uploads/2020/11/0005_3.pdf)	
D4 15:40	ICSAF-0020 [FC] Preparation of phenolic acid and flavonoid nanoemulsions from rabbiteye blueberry leaves and their antiaging effects on mice Shin-Jeng Yu Department of Food Science, Fu Jen Catholic University (Taiwan)	 (https://icsaf.org/wp-content/uploads/2020/11/0020_14.pdf)	 (https://icsaf.org/wp-content/uploads/2020/11/ICSAF-0020-D4.mp4)

6-7 NOVEMBER 2020, NEW TAIPEI CITY, TAIWAN

JOIN THE CONFERENCE

**REGISTRATION
(/REGISTRATION)**

**CONTACT US
(MAILTO:HI@ICSAF.ORG)**



- › Organizers(<https://icsaf.org/organizers>)
- › Committee(<https://icsaf.org/committee>)

- › Keynote Speakers(<https://icsaf.org/keynote-speakers>)
- › Important Dates(<https://icsaf.org/important-dates>)
- › Program(<https://icsaf.org/program>)
- › Presentation(<https://icsaf.org/presentation>)

Registration

- › Author Registration (<https://icsaf.org/registration/author-registration>)
- › Listener Registration (<https://icsaf.org/registration/listener-registration>)

Submission

- › Presentation Guideline (<https://icsaf.org/submission/presentation-guideline>)
- › Presentation Submission (<https://icsaf.org/submission/presentation-submission>)

ICSAF © 2020 All rights reserved