

PAPER NAME

Jonathan Tyar.pdf

WORD COUNT

4238 Words

CHARACTER COUNT

21539 Characters

PAGE COUNT

9 Pages

FILE SIZE

651.0KB

SUBMISSION DATE

Oct 12, 2023 1:15 PM GMT+7

REPORT DATE

Oct 12, 2023 1:15 PM GMT+7

● 13% Overall Similarity

The combined total of all matches, including overlapping sources, for each database.

- 13% Internet database
- 2% Publications database
- Crossref database
- Crossref Posted Content database
- 4% Submitted Works database

● Excluded from Similarity Report

- Bibliographic material
- Quoted material
- Cited material
- Small Matches (Less than 10 words)
- Manually excluded sources

RFID Implementation on Information Recording Systems of Deer

Jonathan Tyar Putro Wicaksono¹, Erdhi Widyarto Nugroho², FX Hendra Prasetya³

^{1,2,3}Department of Information System, Soegijapranata Catholic University
^{1,2,3}Jl. Pawiyatan Luhur Sel. IV No.1, Bendan Duwur, Kota Semarang, Jawa Tengah 50234

¹jonathantyar@gmail.com,

²erdhi@unika.ac.id,

³hendra@unika.ac.id

Abstract— Deer are animals that currently still have conservation status as protected animals. However, for the activities of breeding and caring for deer animals, they are allowed and given legal payment by the government. However, in practice, there is still a lot of illegal deer meat or the result of illegal hunting which is also sold in the Indonesian market. Recording of deer seed genealogy and legality of breeding is one way to differentiate between illegal and legal deer meat sellers. However, due to the manual form of recording, human errors often lead to errors in recording. Therefore we need an application that can handle manual recording coupled with the implementation of RFID on meat so that it is expected to facilitate the existing recording process. The purpose of this research is to create a deer recording system application that can assist users in making sales and purchasing transactions as well as checking the lineage of deer seeds using the implementation of RFID. The method applied is through the design of Use Case Diagrams, Entity Relationship Diagrams, flowcharts, and using the Laravel 7 framework with the application of MVC to produce a Deer Recording System (SRS) application aimed at helping breeders. After the application was generated, testing was carried out on 84 buyers and prospective buyers of deer meat in deer breeding in Kudus, and the results showed that the EE (convenience) and FC (facilities) variables had a significant correlation with the BI variable (desire to return).

Keywords— Deer, Recording System, MVC, Correlation

I. INTRODUCTION

Deer is one of the animals that currently has a conservation status as a protected animal. This is by following PP. 7 of 1999 concerning Preservation of Plant and Animal Species. As a reminder that their status as a protected animal, the circulation of these animals is controlled by the government so that their sustainability is maintained. [1]

Even with its status as a protected animal, the community is allowed to use it. PP No. 8 of 1999 concerning the utilization of wild plant and animal species is the basis for permitting the use of deer. The forms of use that are allowed in following with the PP are study, captivity, research and development, trade, demonstration, exchange, and maintenance for pleasure. [1]

According to Permenhut No. 19 of 2005 concerning the Breeding of Wild Plants and Animals, there are several requirements to establish captivity, one of which is the completeness of documents on the origin of the parent or deer breeding seed. The problem experienced in reindeer breeding is related to the recording of the origin of the parent, which is the difficulty of knowing the male parent because of the natural mating. As well as seeing the recording technology that is currently still being applied by breeders in the form of manual recording in written books or manuals. As well as the need for data that can be accessed and validated by all parties. Therefore, this study will prove a web-based information system with the implementation of RFID which will cover the recording and distribution of venison, which is expected to help deer breeders in the recording process as well as assist the sales and distribution system of meat.

The following is a form of recording before

application, recording is still manual. The following figure below 1 is a recording of the deer and the relationship of the deer itself.

Data Rusa						
No.	Nama	Laki/P	Umur	Tanggal	Jenis	Status Rusa
DE-2872	Levi		19 Januari 2019		Jantan	
DE-28192	Kiduk		27 Des 2018		Jantan	
DE-28193	Kiduk?		15 Mei 2019		Betina	

Hubungan Rusa				
No.	Nama	Catur	Jenis	Hubungan/Status
DE-2872	Levi	19 Januari 2019	Jantan	
DE-28192	Kiduk	27 Des 2018	Jantan	
DE-28193	Kiduk?	15 Mei 2019	Betina	

Figure 1. Form of Deer Recording

The following in Figure 2 is a recording when a cut occurs, the recording is still manual and contains information in the form of the weight of each piece of meat available.

Data Pemotongan						
No.	Nama	Laki/P	Umur	Tanggal	Jenis	Status Rusa
DE-2872	Levi		19 Januari 2019		Jantan	
DE-28192	Kiduk		27 Des 2018		Jantan	
DE-28193	Kiduk?		15 Mei 2019		Betina	

Daging Rusa			
No.	Nama	Berat	Status
1	Levi	12.102 gram	
2	Kiduk	10.092 gram	
3	Kiduk?	10.198 gram	
4	Kiduk dan r. kiduk	12.195 gram	
5	Kiduk	10.221 gram	
6	Kiduk	10.281 gram	
7	Kiduk dan r. kiduk	10.335 gram	
8	Kiduk	10.372 gram	

Figure 2. Form of Recording when a cut occurs

Deer meat itself for sale is divided into pieces that can be processed to be traded or processed into food in the form of steaks, satay, soup, and so on. The cut itself is divided into 9 types, namely neck, ribs, front & hind legs shank, loin, tenderloin, flank, rump, and round.

Even though deer meat has the status of a protected animal, Government Regulation No. 8. of 1999 on Utilization of Wild Plant and Animal Species can be used as the basis for permitting the use of deer meat. As long as the permitted use in accordance with the PP is in the form of study, captivity, research and development, trade, demonstration, exchange, and maintenance for pleasure.

According to Permenhut No. 19 of 2005 concerning the Breeding of Wild Plants and Animals, there are several requirements to establish captivity, one of which is the completeness of documents on the origin of the parent or deer breeding seed. This is the basis of the need for the origin of the parent deer itself to buyers of meat to ensure the legality of the meat.

The application needed is an application that aims to display the recording or pedigree of a farm animal, making it easier for the mating process between livestock to produce superior offspring. Coupled with simple financial management that can provide results in the form of an organization's cash flow and profit and loss statements.

Purchasing meat by the application is provided a menu or a special place on the application for buyers to choose the meat they want to buy from the type, portion, and gender of the meat. After selecting and entering in the cart, the buyer can proceed to go directly to the payment system. After the meat is delivered and gets into the buyer's hands, the buyer can ensure that the meat purchased is in the form of meat that can be legally accounted for by checking the RFID that is attached to the meat during cutting. The origin of deer meat breeds will be seen in the system, it can be used as evidence that the meat comes from captivity and is not meat from illegal hunting.

RFID is a radio frequency delivery technology that many people in the cloud do not know about. RFID itself is an acronym for Radio Frequency Identification which means a technology by utilizing a radio transmission frequency that is owned by a value on a transponder for data transfer over a certain distance. [2]

One of the implementations of tracking goods using the RFID system has also been carried out in the faculty library book detection journal with WEB-based RFID applications. [2]

The working principle of RFID is the naming or marking of an object or item which then we can retrieve the data from the naming or marking through a transponder that captures the radio frequency.

In the published journal, it also explains that Finkenzeller classifies RFID can be used in several fields, including those related to this work, namely access control and animal identification as something that can hold access and identify pets. [3]

A database is a set of data that has a relationship with one another which is related either directly or indirectly and has a meaning and essence that is interconnected or continuous. [4]

The use of databases in recording systems is of course for storing data and its use to link the relationship between data and other data so that it can form a continuity of useful information.

The recording itself is an activity of recording events, incidents, and other important information relating to an object or object. The recording will provide information related to an object so that decision making and information making will be easy to do. [5]

A website is an application that contains content in the form of images, writings, videos, and other media formats, accessible via the internet using the HTTP protocol and a browser for accessing it. The website is divided into two, namely static and dynamic. Static is a website with content that is fixed and does not change while Dynamic is a website that has content that can vary from time to time or each input made by users who access the website. [6]

XAMPP is a software that supports the creation of a website on a local computer or gadget containing modules that support the running of a website on the client-side in the form of Apache, PHP, and Mysql. XAMPP itself is a software with a GPL (General Public License) so that the software can be used by the general public. [7]

An information system is a system, application, or arrangement of computer programs in an organization or group that records every business process activity that is technical, managerial, or strategic according to Leitch and David in the book Jogiyanto (1999: 11). [8]

PHP is an open-source programming

language that is server-side, which is running on the central server-side, in other words, the program is read and processed on the server-side and the processed results will be given to the client-side or commonly referred to as the client-side in the form of layout or commonly referred to as HTML. PHP is also a language that is very commonly used in web development. [9]

MySQL is a DBMS (database management system) as a form of storing relational data sets or what we call RDBMS (relational database management system). With the support for data storage, MySQL is very popular once used on website-based systems or runs on the server-side. [10]

PhpMyAdmin is a software application whose main function is to take care of the MySQL database administration, including managing databases, tables and indexes, and permissions for each database. PhpMyAdmin runs on the PHP programming language and is open source. [11]

Framework or in standard Indonesian can be interpreted as a "work tool" is a tool used by programmers in building a system or application based on a specific programming language. This framework contains a collection of various functions and data management procedures and displays that are ready to use so that it can make it easier for programmers to work without having to create these functions or procedures from scratch. [12]

Laravel is a framework based on PHP programming based on open source created by Taylor Otwell in June 2011 and is currently a fairly popular framework and is used in many projects. The concept of this framework carries the MVC concept, namely the Model View Controller, where the components in this framework are divided into 3 types, namely models related to databases, views related to views, and controllers that combine views and the model itself. [13]

Use Case Diagrams are diagrams whose designation shows the flow of data movement in system design. In DFD there is a process that describes the transfer of data, where the data comes from, and how the data is

processed to produce the desired output. [14]

Waterfall Development Method is an application development method that is structured downwards / sequentially starting from the analysis, design, coding, testing, and support stages. [15]

II. METHOD

A. Research Flowchart

The research was conducted by conducting literature and field studies to collect data, followed by designing an application mock-up and if it was approved, proceed to making the application and continuing with application testing, if the application testing phase had no problem with bugs in the application, then it would be continued with data analysis. Figure 3 below shows the existing research flow.

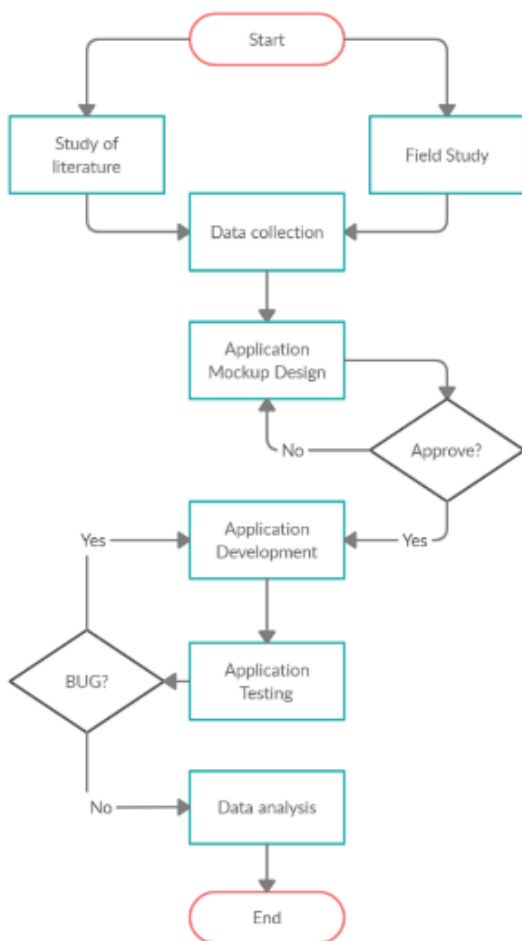

Figure 3. Research Flowchart

B. Primary Data Source

Primary data sources are obtained through direct interviews with organizational actors as

the head of admin, breeders, financial holders, sales and company leaders.

C. Secondary Data Source

Secondary data sources are obtained through journals that have been included in writing and are related to applications that have been made.

D. Method of Collecting Data

1) Document Study

Collecting data by understanding documents related to the problems in research.

2) Literature Study

Collecting accurate data on the topic of the problem that is used as the object of research.

3) Interview

Collecting data by asking questions related to the needs and needs of the application through the seller.

4) Questionnaire

Collecting data by asking respondents several questions. Questionnaires were distributed to respondents who were buyers and had participated in using the application directly in the application business process.

E. Application Design Methods

The method used in application design is the waterfall method which provides a sequential software life flow approach starting from the analysis, design, coding, testing, and support stages.

a. Framework of minds

Figure 4 below is a frame of mind used according to theory and arguments.

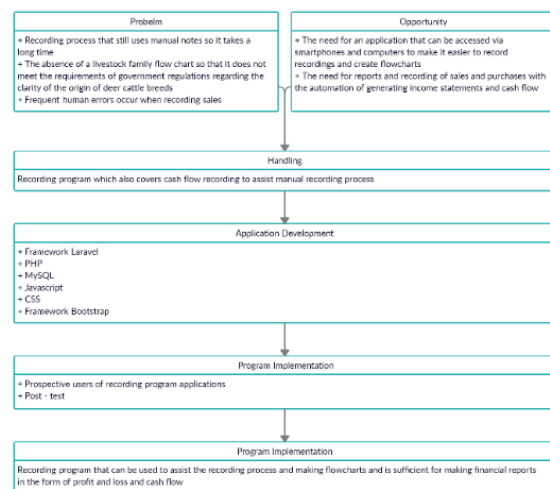

Figure 4. Frame of minds

b. Testing Methods

Tests were carried out using 3 testing methods, namely The Data Validity Test, Data

Reliability Test, and Data Correlation Test. By using these 3 testing methods, it can be ascertained that the data generated from the research questionnaire is valid or accountable. With the relationship between variables as in Figure 5 below.

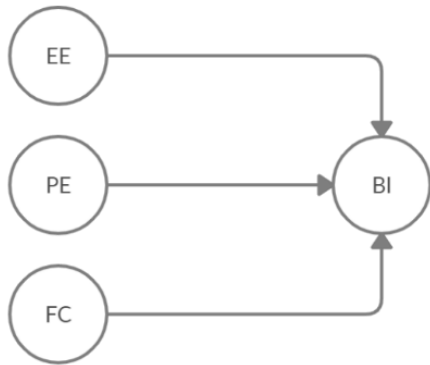

Figure 5 Variables Relationship

III. RESULT AND DISCUSSION

A. Application Design

The Deer Recording System application has the purpose of tracking meat that has been sold to buyers using the implementation of RFID (Radio Frequency Identification) where the process of identifying the meat can be accounted for the origin of the meat and the identity of the legal tender for the origin of the meat.

The Deer Recording System application itself is web-based and can be accessed through the provided domain. In the Deer Recording System application, there are 2 RFID implementation systems, namely for deer as captive animals and for meat as tracking for the authenticity of the meat itself. There are also features for purchasing, delivering meat, and financial reports in the form of cash flow and profit and loss.

Making the application begins with designing a use case diagram. In order to provide an understanding of each function and feature in the application, the diagram can be seen in Figure 6. below this.

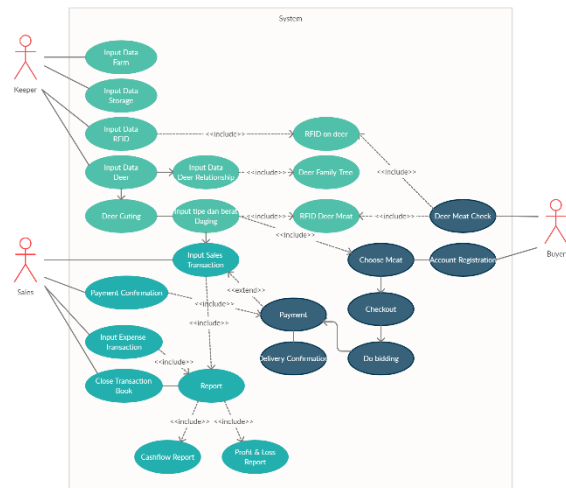

Figure 6. Frame of minds

From the Use Case Diagram above, it can be explained that sellers (breeders and sales) get data input features on farms, warehouses, RFID, deer, deer cutting, expenditure transactions, and income in the application. Meanwhile, buyers get the features of checking meat, buying and paying for meat.

B. Application Development

After designing use cases and entity-relationship diagrams, it will be continued with making flowcharts to provide a simple understanding of the application workflow. Here's a figure of 7. which describes the flowchart of the application.

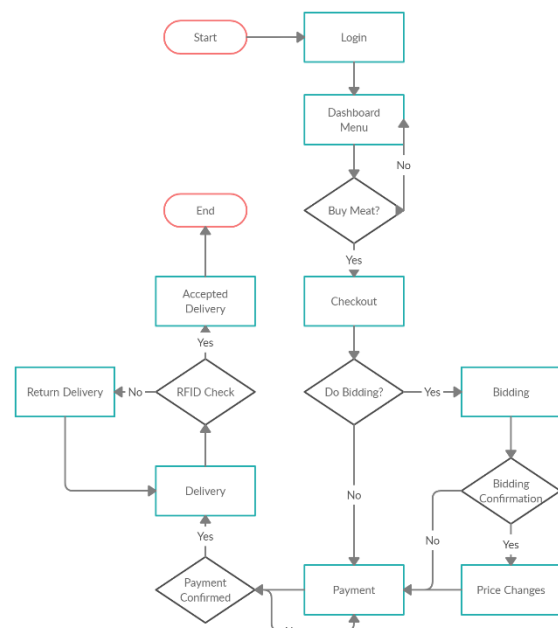

Figure 7. Flowchart Business Process

The way to use the application itself begins with a seller who inputs the meat at the time of slaughtering the deer. Where each piece of meat is given an RFID tag that attaches to the meat before storing it in the refrigerator.

Data from meat that has been input will automatically track its availability by the system where in the sales system, prospective buyers can choose the meat to be included in their shopping cart. When the buyer confirms payment for their shopping cart, the buyer is presented with a feature in the form of a price quote to the seller, where the system will automatically reject the offer if there is no response from the seller for approximately 1 day after the offer is made.

The transaction nominal in each process of buying and selling meat will be automatically tracked and recorded into the transaction reporting system, cash flow, and profit and loss. So that sellers no longer need to input their sales transaction data in the system.

C. Respondent Data Analysis

After testing the application and collecting data by distributing questionnaires to 84 respondents aged between 25-40 years, it is obtained as follows.:

a. Profile of Respondents

1. Age

Most respondents aged 30-35 years with a percentage of 65.5% by represented red colour, followed by respondents aged 25-30 years with a percentage of 21.4% represented by blue colour and most recently 36 years and over with a percentage of 13.1% by orange colour according to Figure 8. which shows a diagram of the respondent's age.

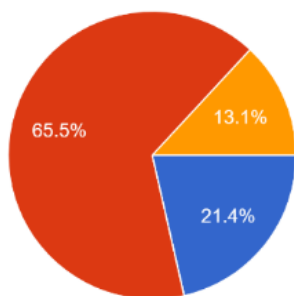

Figure 8 Respondent Age Diagram

2. Gender

Most respondents were men with a percentage of 76.2% represented by blue colour and women with a percentage of 23.8% represented by red colour according to figure 9. which shows the gender diagram of the respondent.

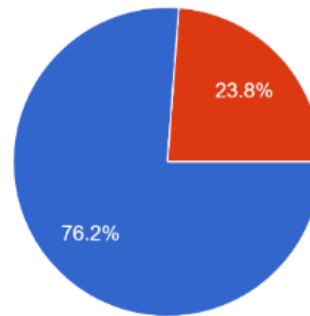

Figure 9 Respondent Gender Diagram

b. List of Questionnaire Questions

The results of the questionnaire data are based on 4 supporting variables, namely EE (convenience), PE (profit), FC (facilitating condition), and BI (periodic use).

Table 1 Data from the questionnaire

EE1	EE2
The Deer Recording System application is easy for you to operate	You don't need special skills to be able to use a deer recording system application
EE3	PE1
you easy to understand deer recording system application	Deer recording system application is useful for tracing the pedigree of the seeds from the meat you buy using RFID
PE2	PE3
Deer Recording System app is useful for buying and offering meat	deer recording system application useful for recording your meat with rfid
FC1	FC2
You have the resources to use deer recording system applications such as web browsers and the internet	You have the knowledge needed to use a deer recording system app
FC3	BI1
You get help from the admin service when you have problems using the deer recording system application	you intend to continue using the deer recording system application
BI2	BI3
You will use a deer recording system application to check and purchase deer meat in the future	You plan to continue using the deer recording system app

D. Research Variable Model

The following is a figure 10 of the research variable model where the independent variable is EE, PE, and FC and the dependent variable is BI.

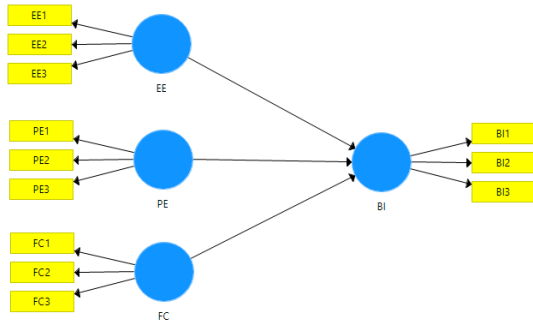

Figure 10. Research Variable Model

E. Validity Test

Table 2 shows evidence of the validity of a questionnaire which can be seen from the clustered (convergent) variables on the Rotated Component Matrix and has a variable value above 0.5. It can be seen in the EE variable which is grouped at the value of 0.574 - 0.823, the PE variable which is grouped at 0.814 - 0.935, the FC variable which is grouped at the value of 0.563 - 0.848 and the BI variable which is grouped at the value of 0.503 - 0.906.

Table 2 Validity Test
Rotated Component Matrix^a

	Component		
	1	2	3
EE1	.765	.210	.360
EE2	.574	-.041	.577
EE3	.823	.175	.300
PE1	.040	.922	.036
PE2	.129	.814	-.015
PE3	.060	.935	.092
FC1	.028	-.054	.848
FC2	.341	.250	.705
FC3	.302	.001	.563
BI1	.906	.057	.213
BI2	.503	.305	.451
BI3	.900	.047	.192

a. Rotation converged in 5 iterations.

a. Reliability Test

In accordance with the data in table 3, which shows the variables EE, PE, BI can be accounted for, while the FC variable shows the questionable where the results of these variables are questionable for reliability.

Table 3 Table of reliability test results

VARIABLE	CRONBACH'S ALPHA	INTERNAL CONSISTENCY
EE	0.869	Good
PE	0.877	Good
FC	0.629	Questionable
BI	0.855	Good

b. Correlation Test

Table 4 shows the correlation between EE and FC variables shows a strong correlation to the BI variable while the PE variable has a weak correlation with the BI variable.

Table 4 Table of correlation test results

		Correlations			
		SEE	SPE	SFC	SBI
SEE	Pearson	1	.226*	.665**	.766**
	Correlation				
	Sig. (2-tailed)		.039	.000	.000
N		84	84	84	84
SPE	Pearson	.226*	1	.176	.242*
	Correlation				
	Sig. (2-tailed)	.039		.109	.027
N		84	84	84	84
SFC	Pearson	.665**	.176	1	.574**
	Correlation				
	Sig. (2-tailed)	.000	.109		.000
N		84	84	84	84
SBI	Pearson	.766**	.242*	.574**	1
	Correlation				
	Sig. (2-tailed)	.000	.027	.000	
N		84	84	84	84

*. Correlation is significant at the 0.05 level (2-tailed).

**.. Correlation is significant at the 0.01 level (2-tailed).

IV. CONCLUSION

The conclusions from the results of the application research are:

1. Designing applications to have a good and correct flow, can be achieved by studying existing documents, conducting literature studies which will later be used in making Use Case Diagrams, Entity Relationship Diagrams and Flowcharts.
2. RFID can help in the indexing process quickly because the data search process is assisted by simply scanning the RFID tag on the RFID reader. To facilitate the process flow of using RFID in the deer indexing process.
3. The effect obtained from making the application can be seen from the results of the questionnaire which shows that users have an understanding that the application provides benefits for them, indicated by the high percentage of agreeing and strongly agreeing with the user benefit category (PE). Although the strong correlation to the BI variables is EE and FC, it can be explained that to strengthen the user's desire to use the application, it is necessary to simplify the application use process and improve existing facilities for the user.

REFERENCES

- [1] M. . Budi Utomo and R. Al Hasan, "Kajian Partisipasi Masyarakat Dan Peran Pemerintah Dalam Kegiatan Penangkaran Dan Konservasi Eksitu Rusa Timor Di Provinsi Nusa Tenggara Barat," *J. Penelit. Sos. dan Ekon. Kehutan.*, vol. 11, no. 2, pp. 165–173, 2014, doi: 10.20886/jsek.2014.11.2.165-173.
- [2] B. Chandrawati, R. Farrid Christanti, and R. Sanjaya, "Deteksi Buku Perpustakaan Fakultas Dengan Aplikasi Rfid Berbasis Web," *Proxies*, vol. 1, no. 1, pp. 32–36–36, 2012.
- [3] F. Ishartomo, P. Basuki, F. Matematika, P. Alam, U. G. Mada, and S. U. Po, "Aplikasi RFID untuk Sistem Identifikasi Stasiun Kereta Api," *IJEIS (Indonesian J. Electron. Instrum. Syst.*, vol. 1, no. 2, pp. 1–10, 2011, doi: 10.22146/ijeis.1924.
- [4] B. Prasetyo, T. J. Pattiasina, and A. N. Soetarmono, "Perancangan dan Pembuatan Sistem Informasi Gudang (Studi Kasus : PT. PLN (Persero) Area Surabaya Barat)," *Teknika*, vol. 4, no. 1, pp. 12–16, 2015, doi: 10.34148/teknika.v4i1.30
- [5] R. Aisuwarya, B. Rahmadya, M. H. Hersyah, R. E. Putri, R. Ferdian, and F. Ardiani, "Implementasi teknologi rfid (," vol. 2, no. 1, pp. 1–13, 2019.
- [6] Samsul Arifin, Yolanda Krisnadita. 2017. Aplikasi Plugin Transfer Domain Di Pt Beon Intermedia. Teknik Informatika, STMIK PPKIA Pradnya Paramita. 8(1): 1
- [7] A. Lena and K. Ratna (2018). "Pengertian PHP dan MySQL," *Ilmu Teknol. Inf.*, pp.2–3.
- [8] Henry C.; Lucas. 1987. Analisis, Desain Dan Implementasi Sistem Informasi ED.3.
- [9] A. Firman, H. F. Wowor, X. Najoan, J. Teknik, E. Fakultas, and T. Unsrat, "Sistem Informasi Perpustakaan Online Berbasis Web," *J. Tek. Elektro dan Komput.*, vol. 5, no. 2, pp. 29–36, 2016, doi: 10.35793/jtek.5.2.2016.11657. Astria Firman, Hans F. Wowor, Xaverius Najoan. 2016. Sistem Informasi Perpustakaan Online Berbasis Web. Jurusan Teknik Elektro Fakultas Teknik UNSRAT. 5(2): 1
- [10] H. Yuliansyah, P. Studi, T. Informatika, and U. Ahmad, "Perancangan Replikasi Basis Data Mysql Dengan Mekanisme Pengamanan Menggunakan Ssl Encryption," *Peranc. Replikasi Basis Data Mysql Dengan Mek. Pengamanan Menggunakan Ssl Encryption*, vol. 8, no. 1, pp. 826–836, 2014, doi: 10.12928/jifo.v8i1.a2081.
- [11] R. E. Standsyah and I. S. N.S Restu, "Implementasi PHPMyAdmin Pada Rancangan Sistem Pengadministrasian," *Unisda J. Math.*

- Comput. Sci., vol. 3, no. 2, pp. 38–44, 2017. Rahmawati Erma Standsyah, Intannia Sari Restu N.S. Implementasi Phpmadmin Pada Rancangan Sistem Pengadministrasian. *Jurnal UJMC Universitas Dr. Soetomo*. 3(2): 39
- [12] T. Bin Tahir, M. Rais, and M. Apriyadi HS, “Aplikasi Point OF Sales Menggunakan Framework Laravel,” *JIKO (Jurnal Inform. dan Komputer)*, vol. 2, no. 2, pp. 55–59, 2019, doi: 10.33387/jiko.v2i2.1313.
- [13] Aminudin. 2015. Cara Efektif Belajar Framework Laravel. Lukmanul Hakim, editor. Yogyakarta(ID): Lokomedia
- [14] Suendri, “Implementasi Diagram UML (Unified Modelling Language) Pada Perancangan Sistem Informasi Remunerasi Dosen Dengan Database Oracle (Studi Kasus: UIN Sumatera Utara Medan),” *J. Ilmu Komput. dan Inform.*, vol. 3, no. 1, pp. 1–9, 2018, [Online]. Available: <http://jurnal.uinsu.ac.id/index.php/algorithm/article/download/3148/1871>.
- [15] A. P. Anggi Oktaviani, Dahlia Sarkawi, “Perancangan Aplikasi Penjualan Dengan Metode Waterfall Pada Koperasi Karyawan Rsud Pasar Rebo,” *Petir*, vol. 11, no. 1, pp. 9–24, 2018, [Online]. Available: <https://stt-pln.ejournal.id/petir/article/view/3>.

● 13% Overall Similarity

Top sources found in the following databases:

- 13% Internet database
- 2% Publications database
- Crossref database
- Crossref Posted Content database
- 4% Submitted Works database

TOP SOURCES

The sources with the highest number of matches within the submission. Overlapping sources will not be displayed.

1	repository.unika.ac.id Internet	11%
2	jurnal.utu.ac.id Internet	<1%
3	cibgp.com Internet	<1%
4	ejournal.nusamandiri.ac.id Internet	<1%
5	"Table of Legislation", Oxford University Press (OUP), 2019 Crossref	<1%
6	semanticscholar.org Internet	<1%

● Excluded from Similarity Report

- Bibliographic material
- Cited material
- Manually excluded sources
- Quoted material
- Small Matches (Less than 10 words)

EXCLUDED SOURCES

journal.unika.ac.id

Internet

77%