

The Appropriate Foundation System for Supporting The Load of Stage House in The Tidal Area (A Case Study in Kemijen Village, Semarang, Indonesia)

Widija Suseno Widjaja*, Etty E. Listiati**, I.M.Tri Hesti Mulyani**, B. Tyas Susanti**

* Department of Civil Engineering, Soegijapranata Catholic University,
Semarang, Indonesia

** Department of Architecture, Soegijapranata Catholic University,
Semarang, Indonesia

DOI: DOI: 10.29322/IJSRP.9.11.2019.p9574

<http://dx.doi.org/10.29322/IJSRP.9.11.2019.p9574>

Abstract- Kemijen is a village in the northern part of Semarang Timur District which is affected by tide. When there is a tide or flood, the residents do land-taking to elevate their houses. Stage house is a suitable house for tidal / flood areas because the floor of the houses becomes higher compared to ordinary houses, without being buried and the floor of the houses will remain dry.

The stage houses that had been tried in Kemijen Village use lightweight building materials considering the carrying capacity of the lands in the tidal or flooded area, so the foundations used are not too large in dimensions.

Concerning the economic conditions of the residents of Kemijen Village with low income, it is necessary to build a cheap but strong and durable foundation. Strong foundation is a foundation that cannot be subsided due to the load to support and must be balanced when subsided. Durable foundation is a foundation that can last a long time in its use in spite of weather impact in dry and wet conditions and potential tidal waves.

Based on the needs above, an appropriate foundation system is needed in the form of raft foundations with bamboo sticks because bamboo sticks can improve poor soil conditions. In addition, raft foundation placed on the top of the bamboo serves as a weight support for stage houses.

Index Terms- Tide, Stage House, Raft Foundation, Foundation System,

I.

INTRODUCTION

Kemijen village is one of the villages in the northern part of Semarang Timur sub-district which is affected by tide and experiences a decrease in environmental quality.

Tidal floods and land subsidence has made residents who live in the area to backfill in an effort to avoid flooding in their houses. For the residents with sufficiently established economic capacity, they can raise their houses. However, this did not help much because almost every 3 to 5 years they still had to repeatedly raise their houses (Listiati, Etty E, et al, 2017).

One effort to overcome the problem of tide and land subsidence with the approach of "raising the house - without filling the ground" is to make a stage house. Stage house is a house with the floors made higher than the ground level by putting up poles. According to Frick (2006), stage houses are usually built on the poles of 60-300 cm high.

In the first year of the research (Listiati, Etty E, et al, 2017), a house concept and design model adapting to tidal floods in Kemijen Village had been built in the form of hydraulic stage house. In the second year of the research (Listiati, Etty E, et al, 2018), a house model that was adaptive to tide in the form of hydraulic house was built. The stage houses can be raised by raising the columns supporting the stage houses using hydraulic jack.

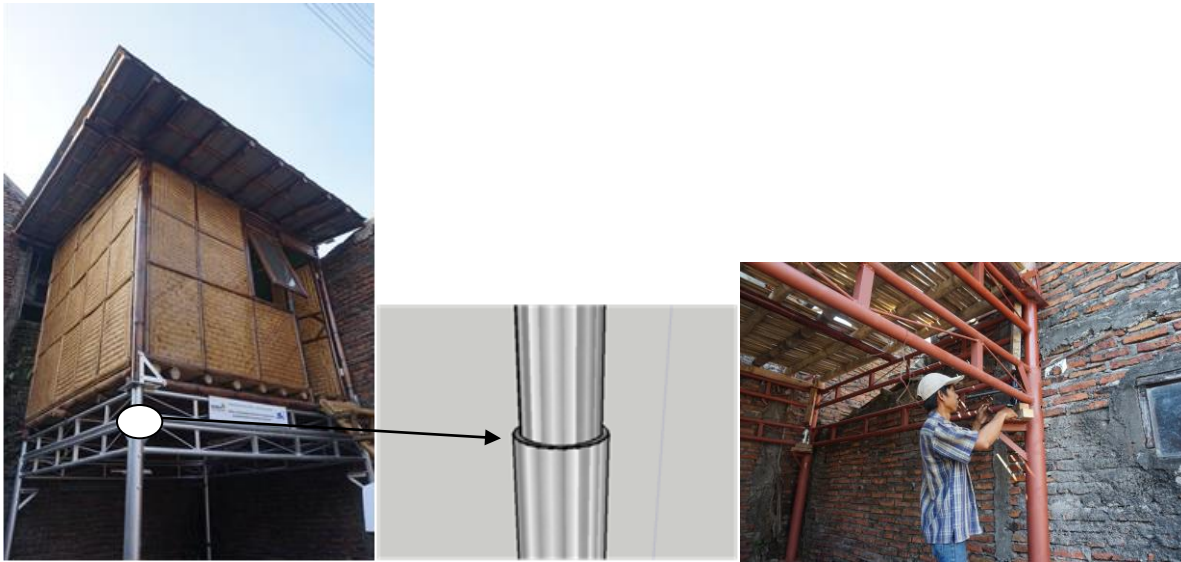

Figure 1: A stage house as a research result that can be raised with a hydraulic system. The design was built on the land owned by Mr. Heriyanto (a resident of RT 02, RW 04 Kemijen Village) which was always flooded



Figure 2: the land of Mr. Heriyanto's house before it was built (Left) and a hydraulic stage house that had already been finished (Right)

In making this stage house, foundation is the most important part to consider because it is located in an area with soft soil condition. The type of foundation used was raft foundation. Considering the condition of soil submerged by tidal water which is very soft soil, bamboo must be installed to provide additional land carrying capacity at the building site.

According to Wahyudi (2015), foundation is a structure on the surface or in a layer of land that functions as a base and also channels the loads originating from the super-structure into the soil.

Planning the lower structure for a building construction is absolutely necessary to be able to maintain the stability of the supported construction. Errors in the calculation of lower structure will cause a sturdy building in the upper structure to collapse and be fatal for its users.

Considering that a stage houses must be raised hydraulically and in order to avoid a subsidence in the house construction, the construction of stage house should be relatively light. To achieve lightweight construction, lightweight wall, floor and roof building materials and appropriate foundation choices were selected.

II. IDENTIFY, RESEARCH AND COLLECT IDEA

In several journals related to this research, one of them states that the structural system components which bear the load of stage house must be easy to implement and safe / strong in carrying the load on it and durable for a certain period of time [5].

In another journal that discusses piles, it is concluded that gelam pile is potentially used as a pile foundation material for swampy areas [6]. Meanwhile, according to Suroso and colleagues, they state that the use of pile on soft clay soils can increase the carrying capacity of soft clay [7]. From the increase in carrying capacity, it shows that the bottom of the pile contributes a significant contribution to soft clay. In their research, the contribution reached 2.2 times stronger than the carrying capacity of soft clay without any pile. The greater the diameter of the overall pile, the higher the effective increase in carrying capacity.

Tjandrawibawa states that many piles are used to reduce the subsidence that will occur [8]. To find out the behavior of the foundation with the pile, a research was carried out in the form of a loading test on a foundation model using "biting" bamboo as a pile. Three types of mounting pile of upright, tilt and upright and tilt combination were carried out in the test. The loading results showed an increase in the carrying capacity of the soil by 60% for sloping pile, 37% for upright pile and 33% when using upright sloping combination. Regarding the selection of raft foundation, the results of Dharmayasa's research state that each raft foundation should be checked for its supporting capacity centrically (the column is right in the middle of plate foundation) and eccentric (the column is not right in the middle of plate foundation). When the results of the plate calculation are mutually close together or even overlapping each other, a continuous plate foundation equipped with beams can be used [9].

III. RESULT AND DISCUSSION

A. Methodology

This study used applied research method; a research that aims to solve existing problems in society (M. Nasir, 1988). The main objective was to provide solutions to problems so that the research results can be used for the benefit of the community. In this approach, a holistic understanding is needed to be able to get a real picture.

To obtain a comprehensive understanding of tidal problem, in this study, interviews and in-depth discussions with the local community through FGD (Forum Group Discussion) were conducted. In addition, location observation also completed the understanding of the existing problems in the community, including the potential (both social potentials and the potential of the availability of materials) that can be used to build hydraulic stage house.

B. Analysis and Discussion

There are numbers of software available which can mimic the process involved in your research work and can produce the possible The foundation system used in the stage house in Kemijen Village consists of three components, i.e.:

1. Bamboo *cerucuk* (local term for bamboo pile raft system)
2. Raft foundation
3. Sloof beam

These three components have their respective functions as follows:

1. **Bamboo *cerucuk***

Bamboo can increase the carrying capacity of lower soil in the form of muddy swamp soil and waterlogging continuously. The efforts to improve the carrying capacity of the soil and to determine the shape of the foundation suitable for the condition of the soil were required.

The efforts to repair poor soils can be made by knowing the thickness of the soil layer and the balancing force on the working foundation load. If the soil layer is poorly thin, generally the soil layer is peeled and replaced with better soil (usually with sand graded soil). If the poor soil layer is deep enough, various efforts can be made such as chemical stability (temporary), mechanical

stability by accelerating consolidation (temporary loading, vertical drainage) or by modifying the type of foundation.

The type of bamboo used for bamboo shoots is *petung* bamboo, which is generally the strongest with short segments are short, and the diameter is 8 to 13 cm with a stem length of 10 to 18 meters. It was cut into one and a half meters long, with the tip taper, so it was easily plugged into the ground. Stored *petung* bamboo was strived to always be in the water or under the lowest water level even during drought.

Before the erection of the bamboo, it was preceded by cleaning and *uitzet* or measurement and bouwplank work so that the spacing of columns or building boundaries to be carried out is really precise and truly in right angle.



Figure 3: Work preparation (site clearing) (left) and *Uitzet* (measurement) building boundaries and bouwplank (right)



Figure 5: Stacking of bamboo pile at the stage house



Figure 6: Preparation of bamboo immersion in tidal water (left) and Immersion for bamboo preservation in the location of the stage house (right)

For bamboo, preservation was carried out in order to prevent pest and fungus attacks. Bamboo contains flour which is preferred by termites. For this reason, all parts of bamboo stems need to be immersed first in water so that the flour can dissolve and ultimately not be liked by termites. Soaking bamboo for preservation was done at the location of the stage house

2. Raft Foundation

After the foundation had been strengthened by the installation of bamboo *cerucuk*, the foundation could be placed directly on the base. The base of foundation must lie under the surface so that it can resist the forces to the sides.

For stage house foundation, due to relatively light / small building, it was sufficient to use a shallow foundation, which is also known as a direct foundation (spread footing) by widening the bottom of the column or wall so that the building load is spread into smaller pressures with the allowable carrying capacity of the land. The base dimensions of the raft foundation are based on the allowable building load and land carrying capacity.

The size of the raft foundation carried out was 60 cm x 60 cm with a thickness of 20 cm on the edges and 35 cm on the part adjacent to the column. Then, the reinforcement used consists of the reinforcement of the foundation raft and column. The reinforcement of the foundation raft used concrete steel with a diameter of 12 mm, with a distance of 20cm

The placement of raft foundation can adjust the environmental conditions where a stage house is built. Raft foundation column does not have to be in the middle, but it can be alongside or at the end of the foundation. In the implementation of its construction, the placement of one raft foundation was placed against the other one as well as different position of the column position so that the building of the stage house can be 'tight' / directly adjacent to the building next to it. The load of this stage house was not too large, so it did not have much effect on the number of reinforcements to the Raft Foundation installed.



Figure 7: Casting of the raft foundation (left) and Ironing of the column (right)

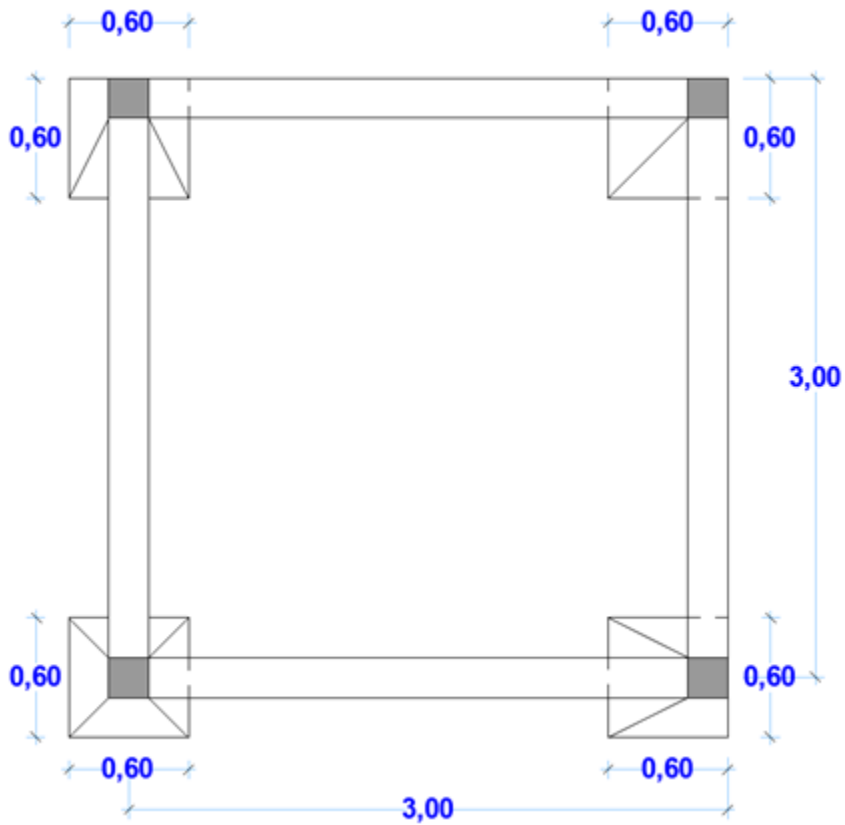

Figure 8: Different column positions in each raft foundation

In the soil layers affected by standing water or tidal disasters, they are usually rather soft or less dense due to the insistence of building foundations on the soil so that it will show a significant subsidence. When this subsidence occurs together at the same time as different subsidence level, problems will arise. The installation of sloof beams that connect the foot of the foundation to one another reduces the significant difference in subsidence.

3. Sloof beam

The sloof beam of the stage houses was made of reinforced concrete with a cross section size of 15 x 25 cm with a reinforcement of 6 Ø 12 and a brace of Ø 8-15 which functions as a binding beam of the raft foundations. These can occur simultaneously.



Figure 9: Casting of sloof beam and raft foundation column (left) and finished casting of sloof beam and raft foundation column (right)

Sloof beams can carry the loads of different foundation subsidence. As a result of this subsidence, the sloof beam has a moment. In addition, it also bears the axial force load of 10% of the column load that works in conjunction with the moment force. This axial force works back and forth as a normal force on the sloof beam so that the calculation can be made like a column calculation. Moments may occur due to the load of upper structure.

There are various types of shallow foundation systems that can be used in the construction of stage houses such as raft foundations, continuous foundations, and raft foundations which are reinforced with bamboo cerucuk. Each type of foundation has advantages and disadvantages, so it must be chosen which one is the most appropriate for an area.

The sloof beams cast on the four sides are able to reinforce the existing foundation system so that one raft foundations and another are completely bound. Likewise, when a stage house will be extended towards the side and the front, the sloof beam will be added in each column of the raft foundation forming a mutually binding network.

The concrete used for casting raft foundation and its columns, along with the sloof beams, must have a good mixture quality, by making a mixture at a planned weight (mixture of 1 Cement: 2 Sand: 3 gravel). Cylindrical specimens are made for the concrete mixture to determine the quality of the planned concrete mixture of K250



Figure 10: Mixing a concrete stir for a concrete cylinder test (left) and making a concrete test specimen (right)

IV. CONCLUSION

- Raft foundation is the most appropriate foundation used in stage houses because it is economical and far more capable of supporting relatively light stage house.
- Plate foundation is used for the adjacent raft foundations, so a continuous plate foundation is more practical to use
- Stage house foundation system with the use of bamboo *cerucuk* and sloop beams will have more convincing ability to reduce land subsidence and uniformly distributed load.
- Sloop beam in stage house foundation system will strengthen the connection between one raft foundation to another one
- The bamboo *cerucuk* used in this study were *petung* bamboo, with perpendicular erection direction, because the location did not allow to be tilted (adjacent to the surrounding walls)

ACKNOWLEDGMENT

Our greatest gratitude is delivered to the Ministry of Research, Technology and Higher Education (Kemenristek DIKTI) who have provided the funding for the Higher Education Applied Research (PTUPT) for 2017-2019 so that this research could be conducted.

REFERENCES

- [1] E. E. Listiati, T. H. Mulyani, W. S. Widjaja and B. T. Susanti, "Model Desain Rumah yang Adaptif Terhadap Rob di Kelurahan Kemijen Semarang (Tahun I)," *Penelitian Terapan Unggulan Perguruan Tinggi Kementerian Riset Teknologi dan Pendidikan Tinggi, Semarang*, 2017.
- [2] H. Frick and T. H. Mulyani, *Arsitektur Ekologis*, Yogyakarta: Penerbit Kanisius, 2006.
- [3] E. E. Listiati, T. H. Mulyani, W. S. Widjaja and B. T. Susanti, "Model Desain Rumah yang Adaptif Terhadap Rob di Kelurahan Kemijen Semarang (Tahun II)," *Penelitian Terapan Unggulan Perguruan Tinggi Kementerian Riset Teknologi dan Pendidikan Tinggi*, 2018.
- [4] H. Wahyudi, *Daya Dukung Pondasi Dangkal*, Surabaya: Institut Teknologi Surabaya, 2015.

- [5] S. B. Pribadi, Indriastiaro, A. R. Wulandari, Y. T. Wibowo, B. Janatin and M. Muzamil, "Sistem Konstruksi Bangunan Sederhana Pada Perbaikan Rumah Warga di Daerah Rob (Studi Kasus: Kelurahan Kemijen, Semarang Timur)," *Modul*, vol. 11, no. 2, pp. 81-88, 2011.
- [6] K. Istanto and A. E. Saputra, "Analisis Model Pondasi Bangunan Air di Atas Tanah Rawa Berbahan Lokal," *TekTan Jurnal Ilmiah Teknik Pertanian*, vol. 5, no. 3, pp. 150-159, 3013.
- [7] H. Suroso and M. Harsono, "Alternatif Perkuatan Tanah Lempung Lunak (Soft Clay) Menggunakan Cerucuk Dengan Variasi Panjang dan Diameter Cerucuk," *Jurnal Rekayasa Sipil*, vol. 2, no. 1, pp. 47-61, 2008.
- [8] S. Tjandrawibawa, J. Efendy and W. Gunawan, "Peningkatan Daya Dukung Pondasi Dangkal Dengan Menggunakan Cerucuk; Suatu Studi Model," *Dimensi Teknik Sipil*, vol. 2, no. 2, pp. 92-95, 2000.
- [9] IGNP Dharmayasa, "Analisa Daya Dukung Pondasi Dangkal pada Tanah Lunak Didaerah Dengan Muka AirTanah Dangkal" *Jurnal Ilmiah Paduraksa*, vol. 2, no 2. Pp 22-30, 2014.
- [10] M. Nazir, *Metode Penelitian*, Jakarta: Ghalia Indonesia, 1988.

AUTHORS

First Author – Widija Suseno, Lecturer on Civil Engineering, Faculty of Engineering, Soegijapranata Catholic University, email:

widija@unika.ac.id

Second author - Etty Endang Listiati, Lecturer on landscape Architecture and Behaviour Architecture, , Faculty of Architecture and Design, Soegijapranata Catholic University, email: etty@unika.ac.id

Third Author- IM.Tri Hesti Mulyani, Lecturer on Ecological Architecture, Dept of Architecture, Faculty of Architecture and Design, Soegijapranata Catholic University, email: mulyani@unika.ac.id.

Fourth author - B.Tyas Susanti, Lecturer on Antropology, Faculty of Architecture and Design, Soegijapranata Catholic University , email: santi@unika.ac.id

Correspondence Author – B.Tyas Susanti, santi@unika.ac.id, contact number +62 813 262 79547