

LAMPIRAN

N O	Nama Ruang	Perabot	Jumlah Perabot	Sumber	Kapas- itas	Jumlah Ruang	Luas (m ²)	Total Luas (m ²)
Area Hunian								
1.	Kamar Lansia <i>Exclusive</i>	Queen size bed (160 x 200 cm)	1	SBR	1 orang	20	36 m ²	720 m²
		Meja Nakas	2					
		Lemari Pakaian	1					
		Rak Barang	1					
		Set mini pantry	1					
		Sofa	2					
		Meja	1					
		Meja dan Kursi kerja set	1					
		Televisi	1					
2.	Kamar Lansia <i>Sharing</i>	Super single/double bed (120 x 200 cm)	2	SBR	2 orang	20	40 m ²	800 m²
		Meja Nakas	3					
		Lemari Pakaian	2					
		Rak Barang	2					
		Meja dan Kursi Kerja	2					
		Televisi	1					
		3.	Kamar Mandi Lansia					
Wastafel	1							
Shower	1							
4.	Kamar Perawat	<i>single bed</i> (90 x 200 cm)	3	NAD	3 orang	6	24 m ²	144 m²
		Meja dan kursi kerja	3					
		Lemari Pakaian	3					
5.	Kamar Mandi Perawat	Closet duduk	1	NAD	1 orang	6	4 m ²	24 m²
		Bak Air	1					
		Wastafel	1					
6.	Area Komunal lansia	Sofa	6	SBR	40 orang	1	110 m ²	110 m²
		Meja	3					

		Rak Barang	3					
		Televisi	1					
		Meja dan Kursi Permainan	2					
		Set Pantry (snack, microwave & coffee maker)	1					
		Lemari Es	2					
		Kursi Pijat						
7.	Ruang Komunal Perawat	Sofa	2	SBR	10 orang	2	36 m ²	72 m²
		Meja	1					
		Kursi	5					
		Pantry	1					
		Rak Buku	2					
8.	Ruang Makan	Meja makan Bundar (6 person)	10 + 3 (tambahan)	HD	80 orang	1	188.7 m ²	188.7 m²
		Kursi Makan	90					
		Meja saji	2					
		Wastafel	4					
		Televisi	2					
9.	Gudang	Lemari Barang	3	AS	2 orang	1	7.8 m ²	7.8 m²
TOTAL =				Sirkulasi 20-30% (+30%)			3323.45 m²	
Area Penunjang								
1.	Ruang Baca	Lemari Buku	6	NAD	25 orang	1	87.5 m ²	87.5 m²
		Sofa	8					
		Meja	4					
		Komputer	4					
2.	Ruang Kegiatan (Musik)	Piano	1	SBR	10 orang	1	48 m ²	48 m²
		Rak Buku	1					
		Rak Angklung	2					
		Rak Gitar	1					
		Kursi	5					
3.	Ruang Kegiatan (Lukis)	Lemari perlengkapan	1	HD	10 orang	1	50 m ²	50 m²
		Rak Barang	1					
		Meja	2					

		Kursi	10					
4.	Ruang Kegiatan (Menjahit & Sulam)	Meja	2	SBR	10 orang	1	45 m ²	45 m²
		Kursi	10					
		Lemari	1					
		Perlengkapan						
		Lemari Display	1					
5.	Gym Center	Treadmill	4	SBR	15 orang	1	96 m ²	96 m²
		Static Bicycle	4					
		Elliptical Machine	3					
		Bench	3					
		Rak Dumbbell	2					
6.	Salon	Backwash Unit	2	HD	2-3 orang	1	45.5 m ²	45.5 m²
		Hair Styling Chair	2					
		Hair Styling Station	2					
		Hair Steamer	1					
		Rak Salon	1					
		Wastafel	1					
7.	Aula/ Ruang Serbaguna	Meja	2	SBR	80 orang	1	275 m ²	275 m²
		Kursi	80					
		Podium	1					
8.	Ruang doa	Kursi	6	TMS NAD	30 orang	1	33 m ²	33 m²
		Meja Altar	1					
		Rak Buku doa	1					
9.	Ruang Kunjungan	Sofa	10	SBR	45 orang	1	80 m ²	80 m²
		Meja	5					
		Pantry	1					
		Televisi	2					
10	Mini Resto	Meja dan Kursi	5	SBR	37 orang	1	176 m ²	176 m²
		Sofa dan Meja	3					
		Televisi	2					
TOTAL =				Sirkulasi 20-30% (+30%)			1.164 m²	
Area Pengelola								
1.	Ruang Kepala	Meja dan Kursi kerja	1	HD	3 orang	1	20 m ²	20 m²
		Lemari Buku	1					
		Loker	2					
		Kursi tamu	2					

		Televisi	1					
2.	Ruang Administrasi	Meja dan Kursi Kerja	2	HD	2 orang	1	12 m ²	12 m²
		Loker	1					
3.	Ruang Staff	Meja dan Kursi Kerja	11	HD	11 orang	1	41.25 m ²	41.25 m²
		Loker	4					
4.	Ruang Rapat	Meja Rapat	1	HD	15 orang	1	56 m ²	56 m²
		Kursi Rapat	15					
4.	Ruang Tamu	Sofa	3	HD	5 orang	1	17 m ²	17 m²
		Meja	1					
5.	Resepsionis	meja	1	HD	2 orang	1	15.75 m ²	15.75 m²
		Kursi	2					
6.	Pantry	Set Pantry	1	HD	3 orang	1	3.2 m ²	3.2 m²
		Lemari Es	1					
7.	Toilet	Closet	3+1	HD PERM EN	6 orang (3 wanita 3 pria)	1	(pria) 8.04 m ² (wanita) 10.85 m ²	18.89 m²
		Urinal	3					
		Wastafel	2+1					
TOTAL =				Sirkulasi 20-30% (+30%)			239.317 m²	
Area Medis								
1.	Ruang Dokter	Kursi dan Meja	1	NAD	4 orang	3	12 m ²	36 m²
		Kursi	2					
		Kasur Medis	1					
		Lemari	1					
		Rak	1					
2.	Ruang Terapis	Kursi dan Meja	1	NAD	3 orang	3	12 m ²	36 m²
		Kursi	2					
		Kasur Medis	1					
		Lemari	1					
		Rak	1					
	Sofa	1						
3.	Ruang Obat	Lemari obat	3	AS	3 orang	1	9 m ²	9 m²
		Meja	1					
		Kursi	1					
4.	Gudang Medis	Lemari Barang	1	AS	2 orang	1	7.84 m ²	7.84 m²
TOTAL =				Sirkulasi 20-30% (+30%)			115.492 m²	

Area Servis								
1.	Dapur	Working Table	1	HD	4 orang	1	28 m ²	28 m²
		Lemari Es	3					
		Stove + Oven	2					
		Kitchen Sink	2					
		Lemari Perlengkapan	3					
		Rak Bumbu	2					
		Meja Saji	1					
		Meja	1					
		Kursi	4					
2.	Laundry	Mesin cuci <i>front loading</i>	4	TMS	4 orang	1	20 m ²	20 m²
		Mesin Pengering	4					
		Meja Setrika	4					
		Rak Perlengkapan	2					
		Lemari Baju	3					
3.	Janitor	Wastafel	1	AS	2 orang	3	7.84 m ²	23.52 m²
		Rak perlengkapan	1					
4.	Garasi	Rak perlengkapan	1	NAD	2 mobil	1	30 m ²	30 m²
5.	Ruang Keamanan	Meja	1	SBR	2 orang	1	10.5 m ²	10.5 m²
		Kursi	2					
		Monitor pantau	3					
		Rak barang	1					
6.	Pos Satpam	Meja dan Kursi	1	AS	2 orang	1	6.25 m ²	6.25 m²
7.	Toilet Umum	Closet	4+1	HD PERM EN	8 orang (4 pria & 4 wanita)	1	(pria) 8.04 m ² (wanita) 10.85 m ²	18.89 m²
		Urinal	3					
		Wastafel	2+1					
8.	Lobby	Sofa	4	SBR	20 orang	1	82.5 m ²	82.5 m²
		Meja	2					
		Lemari Display	2					
TOTAL =				Sirkulasi 20-30% (+30%)			285.56 m²	
TOTAL KESELURUHAN =							<u>5127.819 m²</u>	

Keterangan :

PERMEN : Peraturan Menteri Pekerjaan Umum dan Perumahan Rakyat RI No. 14/PRT/M/2017

HD : “*Human Dimension*” by Julius Pameroy & Martin, New York (1979)

NAD : “*Data Arsitek*” by Ernst Neufert, Jakarta: Erlangga (2002)



TMS : “*Time Saver Standards for Building Types 2nd Edition*” by Joseph De Chiara & John Callender (1983)

AS : Asumsi berdasarkan studi analisis

SBR : Studi Besaran Ruang

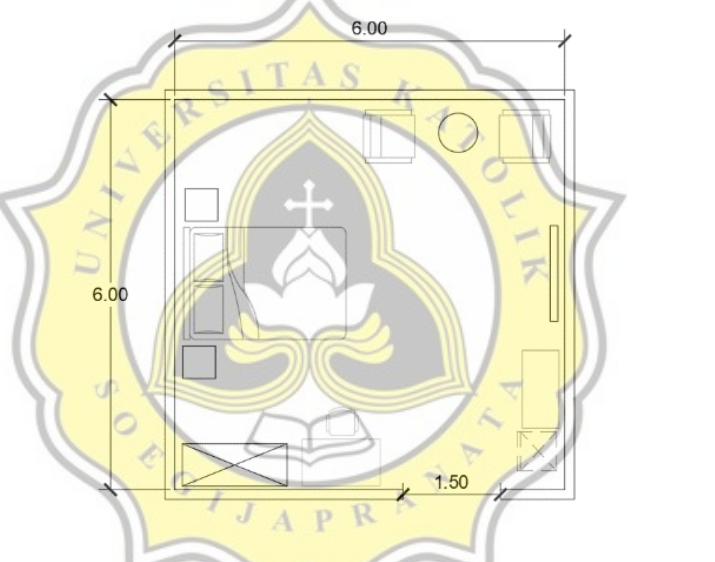
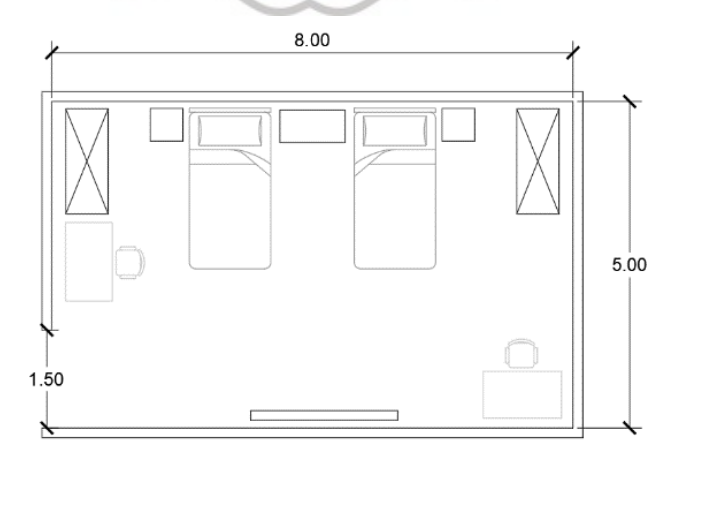
DIMENSI RUANG DALAM (ANALISIS STUDI RUANG)

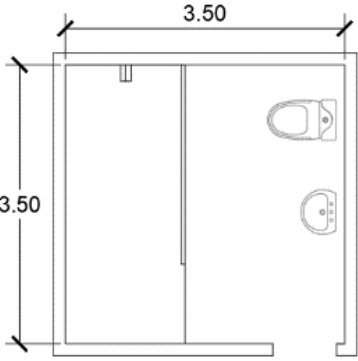
Nama Ruang	Ukuran Ruang	Luas
Kamar Lansia Exclusive		$L = 6 \times 6 \text{ m}$ $= 36 \text{ m}^2$
Kamar Lansia Sharing		$L = 8 \times 5 \text{ m}$ $= 40 \text{ m}^2$

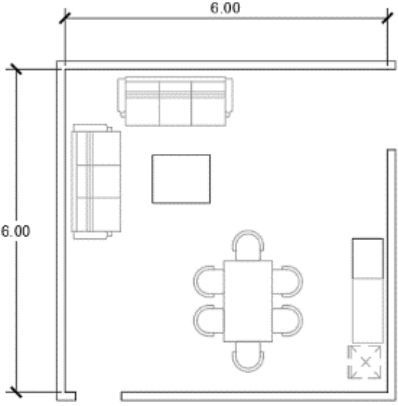
<p>Kamar Mandi Lansia</p>		<p>L = 3.5 x 3.5 m = 12.25 m²</p>
<p>Area Komunal Lansia</p>		<p>L = 10 x 11 = 110 m²</p>
<p>Area Komunal Perawat</p>		<p>L = 6 x 6 m = 36 m²</p>

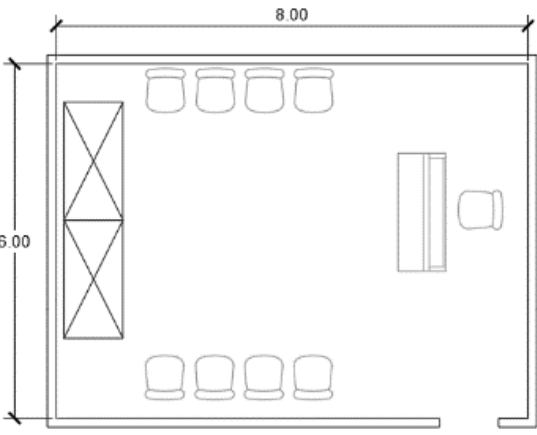
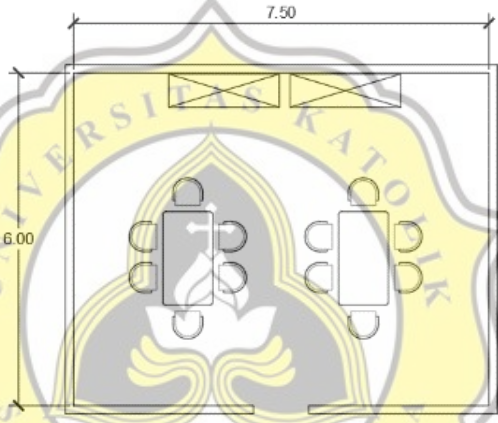
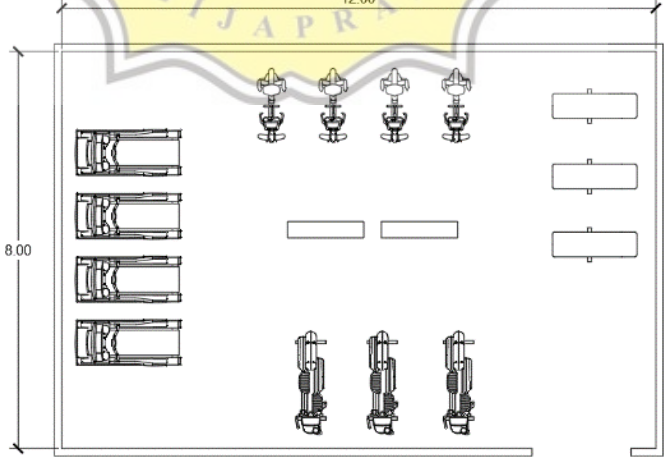
<p>Area Kegiatan (Musik)</p>		<p>$L = 8 \times 6 \text{ m}$ $= 48 \text{ m}^2$</p>
<p>Area Kegiatan (Menjahit)</p>		<p>$L = 7.5 \times 6$ $= 45 \text{ m}^2$</p>
<p>Gym Center</p>		<p>$L = 12 \times 8$ $= 96 \text{ m}^2$</p>

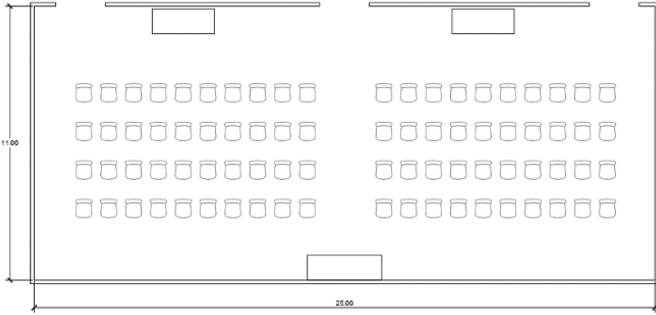
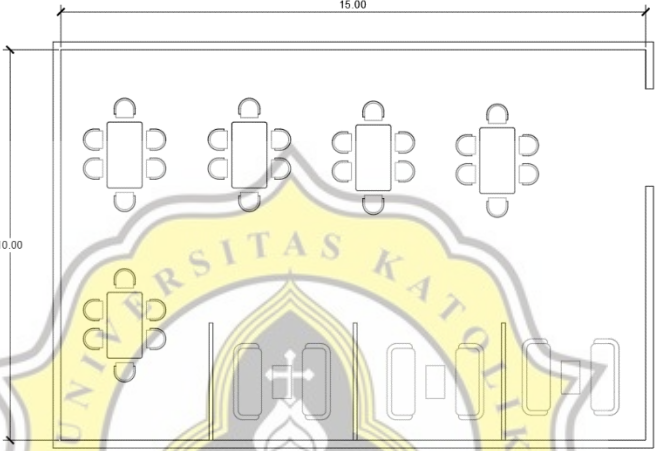
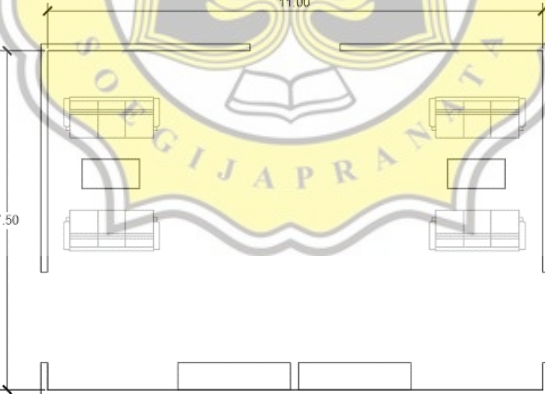
<p>Aula / Ruang Serbaguna</p>		<p>$L = 11 \times 25$ $= 275 \text{ m}^2$</p>
<p>Mini Resto</p>		<p>$L = 11 \times 16$ $= 176 \text{ m}^2$</p>
<p>Lobby</p>		<p>$L = 11 \times 7.5$ $= 82.5 \text{ m}^2$</p>

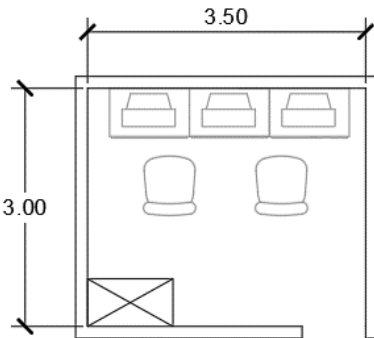
<p>Ruang Keamanan</p>		<p>$L = 3.5 \times 3$ $= 10.5 \text{ m}^2$</p>
-----------------------	---	---

Sumber : Analisis Pribadi

Standar Kamar Mandi Lansia



Sumber : <https://www.archdaily.com/923474/how-to-design-safe-bathrooms-for-the-elderly/5d5ea29b284dd1cd830004c0-how-to-design-safe-bathrooms-for-the-elderly-photo>

Keruangan pada Salon

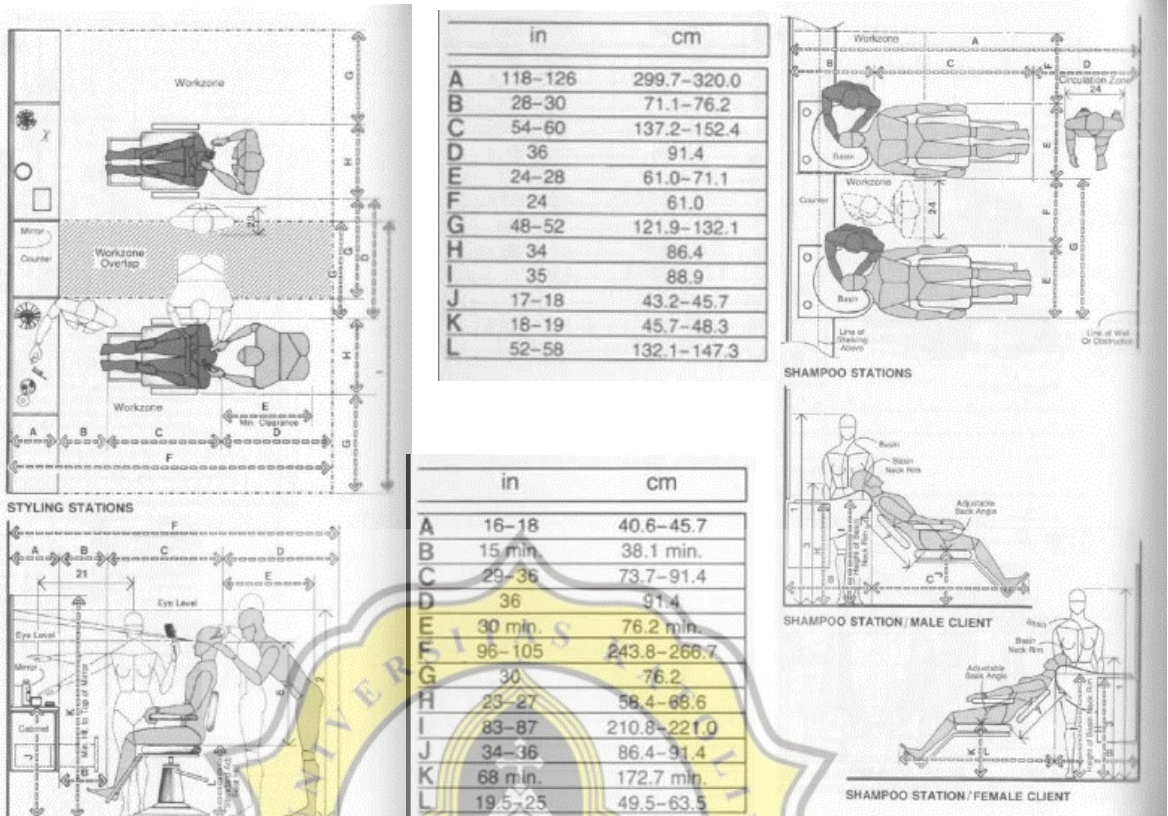

Sumber : Panero (2003). Human Dimension

Dimensi Duduk Normal

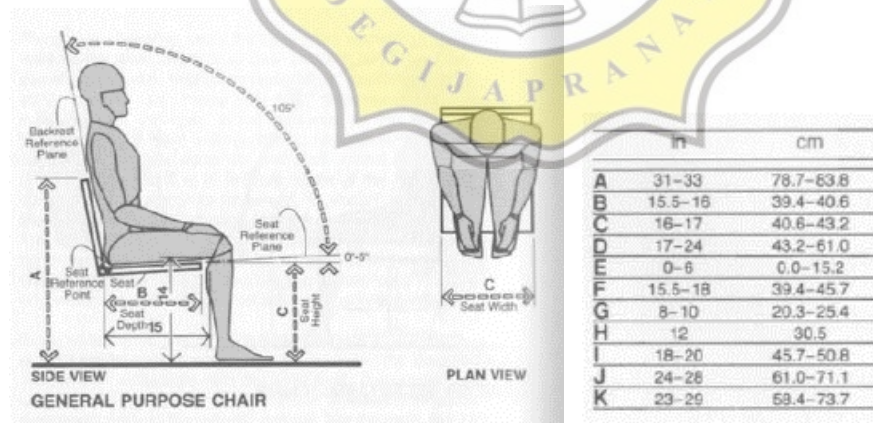

Sumber : Panero (2003). Human Dimension

Dimensi Living Area

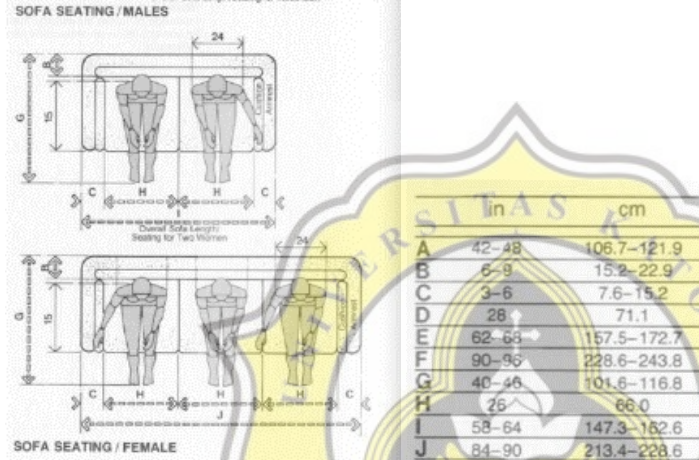
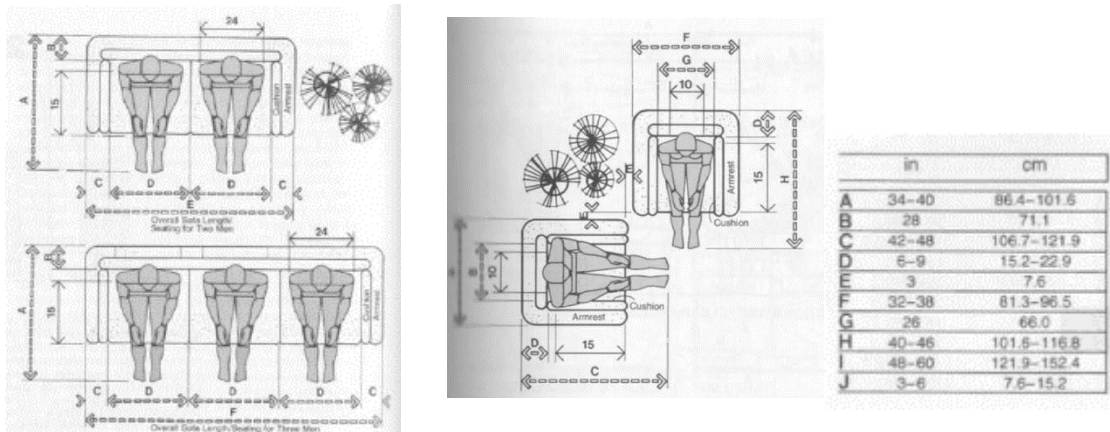

Sumber : Panero (2003). *Human Dimension*

Dimensi Area Makan

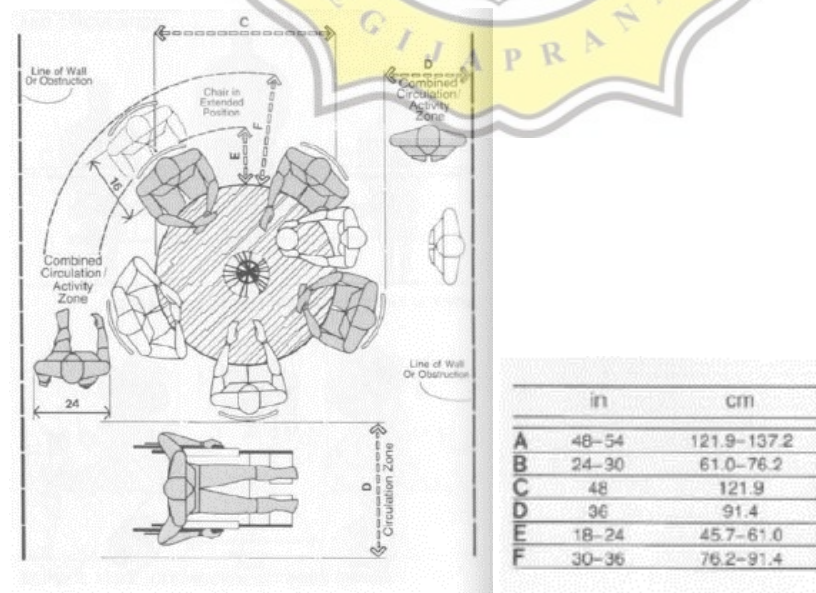

Sumber : Panero (2003). *Human Dimension*

Toilet Umum

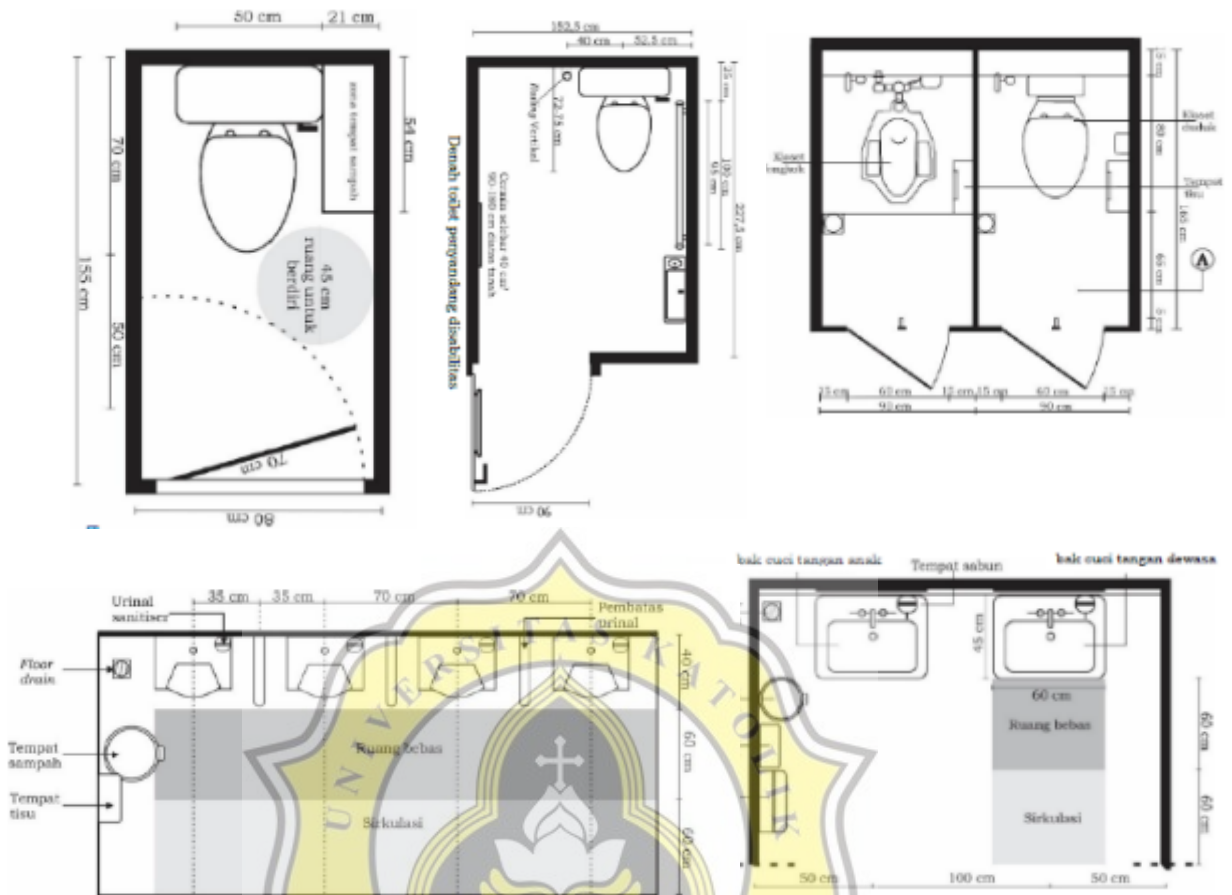

Sumber : Panero (2003). Permen No. 14/PRT/M/2017

Jadwal Kegiatan Wisma Harapan Asri

WISMA LANSIA HARAPAN ASRI
Melayani dg Kasih & Damai
Jl. Tugu 56/6 No. 28 Bekasi - Serpong - Liris Tengah Sipi
Telp. (021) 7413214, Email: harapanasri@gmail.com

NO	HARI	JENIS KEGIATAN	WAKTU	TEMPAT	PENGAMPU
1	SENIN	1. Senam Pagi	07.00	Halaman Wisma	Ibu Puri
		2. Fisio Terapi	09.00	Pendopo/Ruang Penghuni	Ibu Endang
		3. Meditasi Kristiani	16.00	Aula bawah/Kapel	Br. Irena CSA
2	SELASA	1. Doa/Sharing/Renungan	08.30	Kapel	Br. Yohanes
		1. Senam otak dan diabetes	07.00	Halaman dan ruang audio	Maria, Maria, Dian
3	KABU	2. Fisio Terapi	09.00	Pendopo/Ruang Penghuni	Bu Endang
		3. Renungan /doa bersama	16.00	Kapel	Br. Yakobus CSA
		1. Doa Rosario	07.00	Cara Maria	Br. Yohanes CSA
3	KAMIS	1. Fisio Terapi	09.00	Pendopo/Ruang Penghuni	Ibu Endang
3	SAHABU	1. Senam Diabet /Hipertensi	07.00	Halaman	Maria, Maria, Dian
7	MINGGU	1. Misa Kudus dan Bidad Komariz	07.30	Aula Atas	Para Bruder & Bomo
		2. Kesehatan (Brgi yg beragama Kristen)		Meryesantikan	
8	JUMAT PERTAMA	1. Rekoleksi & Ekartasi	16.00	Aula Bawah	Br. Mangun, SJ
		1. Doa Rosario			
9		Ulang Tahun Penghuni Akhir Bulan	10.00	Aula Atas	Anton, Irena, Triyanto

• Papanis Law
• Yaiti Dokter
• Visit Psikolog
• Visit Bakater
• Berek 40 RS dan level
• Miri yak Suci

Br. Yohanes, Br. Yakobus siap ber-
- Br. Michael Setip hari Senin dan Kamis
- Selasa & Jumat
- Sabtu
- Br. Yohanes dan Br. Yakobus
- Propiska, Agustinus, dan Adrien (saworth) bgi yg (saw) Br. Sipi

Serpong, 10 Januari 2020
Br. Heri Suparna, CSA



1.33% PLAGIARISM
APPROXIMATELY

Report #11257646

PENDAHULUAN Latar Belakang Manusia hidup dalam batasan usia dengan melewati fase-fase kehidupan. Semua akan dimulai dengan seorang manusia itu lahir dan menginjak pada fase akhir yakni lanjut usia atau disebut dengan lansia. Dimana fase ini merupakan fase final dalam roda kehidupan manusia yang dimana masa untuk menikmati hasil perjuangan hidup yang sudah mereka jalani selama ini serta arti kata menua merupakan perubahan peran. Berada di usia lansia juga akan timbul beberapa penurunan dan permasalahan kesehatan terutama psikologis mereka. Psikologis pada lansia sendiri dipengaruhi oleh penurunan fungsi kognitif dan psikomotor mereka. Selain itu, sikap atau perasaan lansia yang tidak ingin membebani keluarga menjadi faktor penting. Dimana, lansia masih ingin beraktivitas dan melakukan kegiatan-kegiatan hobi namun tidak memiliki teman atau partner yang dapat membimbing dan menemani kegiatan mereka. Sehingga kondisi tersebut membuat lansia merasa kesepian yang akan mempengaruhi penurunan kesehatan mereka akibat stress dan akan berdampak pada terutama kesehatan psikologis yang akan menurun ke fisik. Menurut WHO dalam situs Geriatri mengenai Lansia Hidup Sendiri dan Risiko Kejahatan (2020), menyebutkan kelompok usia lansia yang tinggal sendiri dikategorikan sebagai kelompok yang berisiko dan membutuhkan perhatian